

PulseStar® 610

Remote Crane Controls

Instruction Manual



ELECTROMOTIVE SYSTEMS
by **MagneTek**

PS610STAN-96A 2/8/00

Part Number: 900-4141

© Copyright 2000 Electromotive Systems

©2000 ELECTROMOTIVE SYSTEMS, INC.

All rights reserved. This notice applies to all copyrighted materials included with this product, including, but not limited to, this manual and software embodied within the product. This manual is intended for the sole use of the persons to whom it was provided, and any unauthorized distribution of the manual or dispersal of its contents is strictly forbidden. This manual may not be reproduced in whole or in part by any means whatsoever without the expressed written permission of ELECTROMOTIVE SYSTEMS, INC.

***DANGER, WARNING, CAUTION, and NOTE* Statements**

DANGER, WARNING, CAUTION, and Note statements are used throughout this manual to emphasize important and critical information. You must read these statements to help ensure safety and to prevent product damage. The statements are defined below.



DANGER

DANGER indicates an imminently hazardous situation which, if not avoided, will result in death or serious injury. This signal word is to be limited to the most extreme situations.



WARNING

WARNING indicates a potentially hazardous situation which, if not avoided, could result in death or serious injury.



CAUTION

CAUTION indicates a potentially hazardous situation which, if not avoided, could result in minor or moderate injury. It may also be used to alert against unsafe practices.

NOTE: A *NOTE* statement is used to notify people of installation, operation, programming, or maintenance information that is important, but not hazard-related.



WARNING

- This manual instructs you how to use PulseStar•610. If you disregard the instructions, information, and/or warranty in the manual, you could be assuming responsibility for damages, costs, or injury incurred by such disregard.
- Do not touch any circuit components on the circuit board while the main AC power is on.
- Do not make any address code or frequency channel changes in the transmitter or receiver without first contacting Electromotive Systems.

Contents

Welcome!	v
PulseStar PS-NVT-J4P-610AS System with Stepped Control	vi
PulseStar PS-NVT-J4P-610AP System with Proportional Control	vii
PulseStar PS-NVT-L4P-610AS System with Stepped Control	viii
PulseStar PS-NVT-L4P-610AP System with Proportional Control	ix
PulseStar PS-GLT-J4P-610AS System with Stepped Control	x
PulseStar PS-GLT-J4P-610AP System with Proportional Control	xi
PulseStar PS-GLT-L4P-610AS System with Stepped Control	xii
PulseStar PS-GLT-L4P-610AP System with Proportional Control	xiii
How to Use This Manual	xiv
Important System Information	xiv

Chapter 1: PulseStar•610 System Overview

PulseStar•610 System Overview	1-3
Introduction	1-3
Theory of Operation	1-3
Active Emergency Stop (E-STOP) Function	1-3
Time-Out Modes	1-4
Receiver Safe Mode	1-4

Chapter 2: The PulseStar•610 Receiver

Overview	2-3
Receiver Components	2-4
GA610AS Receiver	2-4
GA610AP Receiver	2-5
Installing the PulseStar•610 Receiver	2-6
Assessing the Receiver Enclosure Environment	2-6
Serial Nameplate	2-6
Mounting the PulseStar•610 Receiver	2-7
Mounting a Standard External Antenna	2-8
Mounting a Gain Flex Antenna	2-9

Wiring the PulseStar•610 Receiver	2-10
Quick Disconnect Plug	2-10
PulseStar•610 Receiver Wiring Diagrams	2-13
Startup and Test Procedures	2-19
Pre-operation check list	2-19
Testing the Receiver	2-20
Changing the Frequency Channel of the Receiver	2-22

Chapter 3: The PulseStar•610 Transmitter

Overview	3-3
PulseStar•610 Transmitters	3-4
NVT Transmitter	3-4
GLT Transmitter	3-7
Transmitter Setup	3-10
Transmitter Address Code and Frequency Channel	3-10
Setting the Address Code and Frequency Channel of a Transmitter	3-11
Start-up and Operation	3-16
Holding the Transmitter	3-16
Start-up	3-18
Shutting Off the Transmitter	3-19
Transmitter Options	3-19
Spare Transmitter	3-19
Battery and Charger Information	3-20
Removing and Inserting the Battery From the NVT Transmitter	3-20
Removing and Inserting the Battery From the GLT Transmitter	3-21
Charging the Battery	3-22
Memory Effect	3-23

Chapter 4: Troubleshooting PulseStar•610

Troubleshooting	4-3
Introduction	4-3
Common Problems	4-3
Questions to Ask	4-6

Appendix A: Definitions and Abbreviations

Definitions and Abbreviations	A-3
Definitions	A-3
Commonly Used Abbreviations	A-4

Appendix B: Specifications

Specifications	B-3
System Specifications	B-3
NVT Specifications	B-3
GLT Specifications	B-4
Receiver Specifications	B-4

Appendix C: StarService and Warranty

StarService Policy	C-3
On-Call Service	C-3
Warranty	C-3
Transmitter Loaner, Replacement & Repair Program	C-3
Receiver Repair Program	C-4
Limited Warranty And Terms Of Sale	C-5
Special Terms and Conditions: Orders of \$25,000 or More	C-6
Special Terms and Conditions: Orders for Special Control Panels	C-6

This page intentionally left blank.

Welcome!

Welcome to the PulseStar•610 radio remote crane control system. Electromotive Systems has set a whole new standard in radio-remote performance, dependability, and value with this unique new line of modular transmitters and receivers. Without a doubt, PulseStar•610 is the ultimate solution for having precise, untethered, and safe control of overhead loads.

Using state-of-the-art synthesizer technology and the best circuit board manufacturing designs available, Electromotive Systems has eliminated many of the unreliable and expendable electromechanical components found in traditional radio remote systems.

The PulseStar•610 system consists of a receiver and a belly box transmitter. The system uses PulseStar's synthesizer technology and operates over the 400-470 MHz band. PulseStar•610 is FCC approved with no site license required.

PulseStar's unique transmitter and receiver design provide a sophisticated, yet easy-to-understand, efficient, and safe radio remote control. PulseStar's modular design has the following advantages:

- Flexible design allows easy mixing and matching.
- On-board diagnostics allow easy troubleshooting.
- Standardized spare parts; kits available.
- Simple design.

PulseStar PS-NVT-J4P-610AS System with Stepped Control

The PulseStar PS-NVT-J4P-610AS system with stepped control consists of a GA610AS receiver and NVT-J4P transmitter kit. The PS-NVT-J4P-610AS system is used for remote control of one (1) four motion, five speed crane.

GA610AS Receiver

The GA610AS receiver is provided with:

- Twenty four motion relays for discreet output to adjustable frequency drives and/or contactors.
- **START** relay.
- **HORN** relay.
- Two **SELECTOR** relays.
- One **OPTION** relay.
- **Active E-STOP** relay.
- Self-diagnostics to ensure trouble-free operation.
- 16-bit address security code (over 65,000 possibilities).
- Miniflex antenna with 330 foot range.
- IP65 weatherproof enclosure.

NVT-J4P Transmitter Kit

The NVT-J4P four motion transmitter kit is provided with:

- NVT-J4P transmitter.
 - Two dual-axis proportional joysticks.
 - **START/HORN** push-button.
 - **Active E-STOP** for immediate stopping action.
 - One three position maintained **SELECTOR** toggle switch for a, a+b, b select.
 - One two position maintained **OPTION** toggle switch.
 - Removable key switch for added security.
 - 16-bit address security code (over 65,000 possibilities).
 - Internal antenna with 330 foot range.
 - IP65 weatherproof enclosure.
 - Waist belt.
- Discharge before charging battery charger.
- Two high capacity rechargeable batteries.

PulseStar PS-NVT-J4P-610AP System with Proportional Control

The PulseStar PS-NVT-J4P-610AP system with proportional control consists of a GA610AP receiver and NVT-J4P transmitter kit. The PS-NVT-J4P-610AP system is used for remote control of one (1) four motion, crane which is controlled by adjustable frequency drives and programmed for proportional 0-10vdc control.

GA610AP Receiver

The GA610AP receiver is provided with:

- Four sets of directional contacts and SYM-2 0-10vdc modules for proportional control of adjustable frequency drives.
- **START** relay.
- **HORN** relay.
- Two **SELECTOR** relays.
- One **OPTION** relay.
- **Active E-STOP** relay.
- Self-diagnostics to ensure trouble-free operation.
- 16-bit address security code (over 65,000 possibilities).
- Miniflex antenna with 330 foot range.
- IP65 weatherproof enclosure.

NVT-J4P Transmitter Kit

The NVT-J4P four motion transmitter kit is provided with:

- NVT-J4P transmitter.
 - Two dual-axis proportional joysticks.
 - **START/HORN** push-button.
 - **Active E-STOP** for immediate stopping action.
 - One three position maintained **SELECTOR** toggle switch for a, a+b, b select.
 - One two position maintained **OPTION** toggle switch.
 - Removable key switch for added security.
 - 16-bit address security code (over 65,000 possibilities).
 - Internal antenna with 330 foot range.
 - IP65 weatherproof enclosure.
 - Waist belt.
- Discharge before charging battery charger.
- Two high capacity rechargeable batteries.

PulseStar PS-NVT-L4P-610AS System with Stepped Control

The PulseStar PS-NVT-L4P-610AS system with stepped control consists of a GA610AS receiver and NVT-L4P transmitter kit. The PS-NVT-L4P-610AS system is used for remote control of one (1) four motion, five speed crane.

GA610AS Receiver

The GA610AS receiver is provided with:

- Twenty four motion relays for discreet output to adjustable frequency drives and/or contactors.
- **START** relay.
- **HORN** relay.
- Two **SELECTOR** relays.
- One **OPTION** relay.
- **Active E-STOP** relay.
- Self-diagnostics to ensure trouble-free operation.
- 16-bit address security code (over 65,000 possibilities).
- Miniflex antenna with 330 foot range.
- IP65 weatherproof enclosure.

NVT-L4P Transmitter Kit

The NVT-L4P four motion transmitter kit is provided with:

- NVT-L4P transmitter.
 - Four single-axis proportional paddle levers.
 - **START/HORN** push-button.
 - **Active E-STOP** for immediate stopping action.
 - One three position maintained **SELECTOR** toggle switch for a, a+b, b select.
 - One two position maintained **OPTION** toggle switch.
 - Removable key switch for added security.
 - 16-bit address security code (over 65,000 possibilities).
 - Internal antenna with 330 foot range.
 - IP65 weatherproof enclosure.
 - Waist belt.
- Discharge before charging battery charger.
- Two high capacity rechargeable batteries.

PulseStar PS-NVT-L4P-610AP System with Proportional Control

The PulseStar PS-NVT-L4P-610AP system with proportional control consists of a GA610AP receiver and NVT-L4P transmitter kit. The PS-NVT-L4P-610AP system is used for remote control of one (1) four motion, crane which is controlled by adjustable frequency drives and programmed for proportional 0-10vdc control.

GA610AP Receiver

The GA610AP receiver is provided with:

- Four sets of directional contacts and SYM-2 0-10vdc modules for proportional control of adjustable frequency drives.
- **START** relay.
- **HORN** relay.
- Two **SELECTOR** relays.
- One **OPTION** relay.
- **Active E-STOP** relay.
- Self-diagnostics to ensure trouble-free operation.
- 16-bit address security code (over 65,000 possibilities).
- Miniflex antenna with 330 foot range.
- IP65 weatherproof enclosure.

NVT-L4P Transmitter Kit

The NVT-L4P four motion transmitter kit is provided with:

- NVT-L4P transmitter.
 - Four single-axis proportional paddle levers.
 - **START/HORN** push-button.
 - **Active E-STOP** for immediate stopping action.
 - One three position maintained **SELECTOR** toggle switch for a, a+b, b select.
 - One two position maintained **OPTION** toggle switch.
 - Removable key switch for added security.
 - 16-bit address security code (over 65,000 possibilities).
 - Internal antenna with 330 foot range.
 - IP65 weatherproof enclosure.
 - Waist belt.
- Discharge before charging battery charger.
- Two high capacity rechargeable batteries.

PulseStar PS-GLT-J4P-610AS System with Stepped Control

The PulseStar PS-GLT-J4P-610AS system with stepped control consists of a GA610AS receiver and GLT-J4P transmitter kit. The PS-GLT-J4P-610AS system is used for remote control of one (1) four motion, five speed crane.

GA610AS Receiver

The GA610AS receiver is provided with:

- Twenty four motion relays for discreet output to adjustable frequency drives and/or contactors.
- **START** relay.
- **HORN** relay.
- Two **SELECTOR** relays.
- One **OPTION** relay.
- **Active E-STOP** relay.
- Self-diagnostics to ensure trouble-free operation.
- 16-bit address security code (over 65,000 possibilities).
- Miniflex antenna with 330 foot range.
- IP65 weatherproof enclosure.

GLT-J4P Transmitter Kit

The GLT-J4P four motion transmitter kit is provided with:

- GLT-J4P transmitter.
 - Two dual-axis proportional joysticks.
 - **START/HORN** push-button.
 - **Active E-STOP** for immediate stopping action.
 - One three position maintained **SELECTOR** toggle switch for a, a+b, b select.
 - One two position maintained **OPTION** toggle switch.
 - Removable key switch for added security.
 - 16-bit address security code (over 65,000 possibilities).
 - Internal antenna with 330 foot range.
 - IP65 weatherproof enclosure.
 - Waist belt.
- Discharge before charging battery charger.
- Two high capacity rechargeable batteries.

PulseStar PS-GLT-J4P-610AP System with Proportional Control

The PulseStar PS-GLT-J4P-610AP system with proportional control consists of a GA610AP receiver and GLT-J4P transmitter kit. The PS-GLT-J4P-610AP system is used for remote control of one (1) four motion, crane which is controlled by adjustable frequency drives and programmed for proportional 0-10vdc control.

GA610AP Receiver

The GA610AP receiver is provided with:

- Four sets of directional contacts and SYM-2 0-10vdc modules for proportional control of adjustable frequency drives.
- **START** relay.
- **HORN** relay.
- Two **SELECTOR** relays.
- One **OPTION** relay.
- **Active E-STOP** relay.
- Self-diagnostics to ensure trouble-free operation.
- 16-bit address security code (over 65,000 possibilities).
- Miniflex antenna with 330 foot range.
- IP65 weatherproof enclosure.

GLT-J4P Transmitter Kit

The GLT-J4P four motion transmitter kit is provided with:

- GLT-J4P transmitter.
 - Two dual-axis proportional joysticks.
 - **START/HORN** push-button.
 - **Active E-STOP** for immediate stopping action.
 - One three position maintained **SELECTOR** toggle switch for a, a+b, b select.
 - One two position maintained **OPTION** toggle switch.
 - Removable key switch for added security.
 - 16-bit address security code (over 65,000 possibilities).
 - Internal antenna with 330 foot range.
 - IP65 weatherproof enclosure.
 - Waist belt.
- Discharge before charging battery charger.
- Two high capacity rechargeable batteries.

PulseStar PS-GLT-L4P-610AS System with Stepped Control

The PulseStar PS-GLT-L4P-610AS system with stepped control consists of a GA610AS receiver and GLT-L4P transmitter kit. The PS-GLT-L4P-610AS system is used for remote control of one (1) four motion, five speed crane.

GA610AS Receiver

The GA610AS receiver is provided with:

- Twenty four motion relays for discreet output to adjustable frequency drives and/or contactors.
- **START** relay.
- **HORN** relay.
- Two **SELECTOR** relays.
- One **OPTION** relay.
- **Active E-STOP** relay.
- Self-diagnostics to ensure trouble-free operation.
- 16-bit address security code (over 65,000 possibilities).
- Miniflex antenna with 330 foot range.
- IP65 weatherproof enclosure.

GLT-L4P Transmitter Kit

The GLT-L4P four motion transmitter kit is provided with:

- GLT-L4P transmitter.
 - Four single-axis proportional paddle levers.
 - **START/HORN** push-button.
 - **Active E-STOP** for immediate stopping action.
 - One three position maintained **SELECTOR** toggle switch for a, a+b, b select.
 - One two position maintained **OPTION** toggle switch.
 - Removable key switch for added security.
 - 16-bit address security code (over 65,000 possibilities).
 - Internal antenna with 330 foot range.
 - IP65 weatherproof enclosure.
 - Waist belt.
- Discharge before charging battery charger.
- Two high capacity rechargeable batteries.

PulseStar PS-GLT-L4P-610AP System with Proportional Control

The PulseStar PS-GLT-L4P-610AP system with proportional control consists of a GA610AP receiver and GLT-L4P transmitter kit. The PS-GLT-L4P-610AP system is used for remote control of one (1) four motion, crane which is controlled by adjustable frequency drives and programmed for proportional 0-10vdc control.

GA610AP Receiver

The GA610AP receiver is provided with:

- Four sets of directional contacts and SYM-2 0-10vdc modules for proportional control of adjustable frequency drives.
- **START** relay.
- **HORN** relay.
- Two **SELECTOR** relays.
- One **OPTION** relay.
- **Active E-STOP** relay.
- Self-diagnostics to ensure trouble-free operation.
- 16-bit address security code (over 65,000 possibilities).
- Miniflex antenna with 330 foot range.
- IP65 weatherproof enclosure.

GLT-L4P Transmitter Kit

The GLT-L4P four motion transmitter kit is provided with:

- GLT-L4P transmitter.
 - Four single-axis proportional paddle levers.
 - **START/HORN** push-button.
 - **Active E-STOP** for immediate stopping action.
 - One three position maintained **SELECTOR** toggle switch for a, a+b, b select.
 - One two position maintained **OPTION** toggle switch.
 - Removable key switch for added security.
 - 16-bit address security code (over 65,000 possibilities).
 - Internal antenna with 330 foot range.
 - IP65 weatherproof enclosure.
 - Waist belt.
- Discharge before charging battery charger.
- Two high capacity rechargeable batteries.

How to Use This Manual

PulseStar•610 Instruction Manual has a comprehensive introduction chapter that you should read before installing, wiring, or operating the system. It introduces some of the PulseStar features, and the different components of the transmitter.

Chapter 2 covers installing and wiring the receiver, as well as start-up and test procedures to make sure the system is working properly before you begin regular operation.

Chapter 3 covers address code and frequency channel setup, start up, and how to operate the PulseStar•610 transmitter.

Chapter 4 gives you a basic troubleshooting guide, plus a checklist of things to look for before calling Electromotive Systems for service. In most cases, problems are minor and easy to solve.

Important System Information

Before operating PulseStar•610, read this important system information.

- Resistor-Capacitor (RC) type surge suppressors must be used when the PulseStar•610 receiver is controlling magnetic contactors.
- When not in use, the transmitter should be turned off and stored in a safe place to prevent unauthorized users from operating it.
- If the crane fails to respond properly, stop operation immediately, turn off the transmitter, and report the condition immediately to an appropriate technician or supervisor.
- Wire the receiver circuit board to the crane's ground.
- When using a standard external antenna mount it on a conductive metal surface with the same ground as the receiver circuit board. Remove any burrs from the antenna mounting hole and scrape away any paint which may prohibit the antenna base from making a good ground contact with the surface. Make sure that the antenna is not surrounded by metal or other conductive materials. Failure to properly install the antenna will result in intermittent operation.
- When using a gain flex external antenna make sure that your mounting location is at least 2 meters (6 feet) from any metallic or conductive objects. These objects may interfere with the antenna and cause intermittent operation.
- Before working on the transmitter, turn off the key switch and remove the battery.
- When taking a break or changing the battery, turn the transmitter off with the key switch.
- Always have a battery in the battery charger to ensure a fully charged battery.
- Perform initial setup or service work only if you have been authorized to do so. Use only Electromotive Systems spare parts.
- If your facility has more than one PulseStar remote radio control system, and the systems operate within 200 feet of one another, the frequency channels for each system must be at least two channels apart. If the systems operate within 50 feet of one another, the frequency channel for each system must be at least three channels apart.

c h a p t e r **1**

**PulseStar•610
System Overview**

This page is intentionally left blank.

PulseStar•610 System Overview

Introduction

This chapter introduces the basic conceptual information that you should know before installing, wiring, and operating the PulseStar•610 system.

Theory of Operation

The PulseStar•610 system consists of a transmitter kit and a receiver. The transmitter, using PulseStar's synthesizer technology, electronically generates a carrier frequency over which it and the receiver communicate. PulseStar•610 transmitters and receivers operate over the 400-470 Mhz frequency range (70 cm. band). To guarantee safety when the crane is being operated in conjunction with other radio controls, the receiver and transmitter are configured with the same address code. This way, the receiver only seeks out and accepts commands from the transmitter with the same address code.

NOTE: *The PulseStar•610 receiver and transmitter already have their address code set up before they are shipped. Never change the address code in the receiver. The only time you should need to change the address code inside the transmitter is when you are setting up a spare or replacement transmitter. If you have any questions about address codes and how they are used, contact Electromotive Systems.*

Active Emergency Stop (E-STOP) Function

One of the most important features of the PulseStar•610 is **Active E-STOP**. The transmitter continuously sends the **Active E-STOP** status signal, followed by the desired crane function. This constant communication between the transmitter and the receiver confirm that the ongoing operations are safe. If the **Active E-STOP** push-button is pressed on the transmitter, the **Active E-STOP** relay module in the receiver opens, and crane motion then ceases. The receiver is then in **Safe Mode**.

To restart the system after activating **Active E-STOP** via the **Active E-STOP** push-button, pull out the **Active E-STOP** push-button and press the **START/HORN** push-button.

NOTE: *There are other situations in which the system automatically goes into Active E-STOP without the operator pressing the Active E-STOP push-button on the transmitter. These are explained in later sections of the manual.*

Active E-STOP responds faster than any other PulseStar function. When **Active E-STOP** occurs, the system ignores any other signal it receives. **Active E-STOP** is the only signal that is recognized until the problem is corrected.

Active E-STOP is fail-safe and self-monitoring in both the transmitter and receiver. When you apply power to the receiver, it performs a self-test to make sure the **Active E-STOP** circuitry is working properly. If the receiver detects an error in the **Active E-STOP** circuitry, the system automatically goes into **Safe Mode**.

When you first turn on the transmitter, it also performs a self-test to make sure CPU circuitry is working properly. If it detects an error, the transmitter will not begin transmitting.

Time-Out Modes

Receiver Safe Mode

A PulseStar•610 safety feature is the **Safe Mode**. The receiver will go into **Safe Mode** if any of the following should occur.

- Interference caused by other transmitters or other radio-controlled products in the area.
- The transmitter is taken out of its operating range (330 feet).
- The **Active E-STOP** push-button is activated.
- There is a failure with the **Active E-STOP** circuitry.

When the receiver loses the transmitter carrier frequency signal, the **Time Out Waiting Period** process begins. The **Time Out Waiting Period** is factory set at 450msec, however it can be extended to 2 seconds. If the receiver does not regain the transmitter carrier frequency signal before the **Time Out Waiting Period** expires, the receiver immediately goes into **Safe Mode**. When in **Safe Mode** the receiver shuts off power to the output modules, and drops out the mainline contactor by opening the **Active E-STOP** relay module.

To restart the system, make sure the transmitter carrier frequency signal is being picked up by the receiver. Then press the **START/HORN** push-button on the transmitter.

c h a p t e r **2**

The PulseStar•610 Receiver

This page is intentionally left blank.

Overview

This chapter tells you how to install and wire the PulseStar•610 receiver. It also contains start-up and test procedures so you can ensure that the receiver is working properly before you actually use the PulseStar•610 system to control the overhead crane.

This chapter covers the following information.

- Receiver Components
- Installing the PulseStar•610 Receiver
- Wiring the PulseStar•610 Receiver
- Startup and Test Procedures



WARNING

Only authorized personnel are permitted to perform the initial installation, setup or service work.
Use only Electromotive Systems spare parts.

Receiver Components

The PulseStar•610 receiver receives commands from the remote transmitter, and interfaces with the crane controls to move the crane.

GA610AS Receiver

The PulseStar GA610AS receiver is used for up to 5 step control of variable frequency drives and/or contactors. See Figure 2.1: PulseStar GA610AS Receiver Layout for the location of various components.

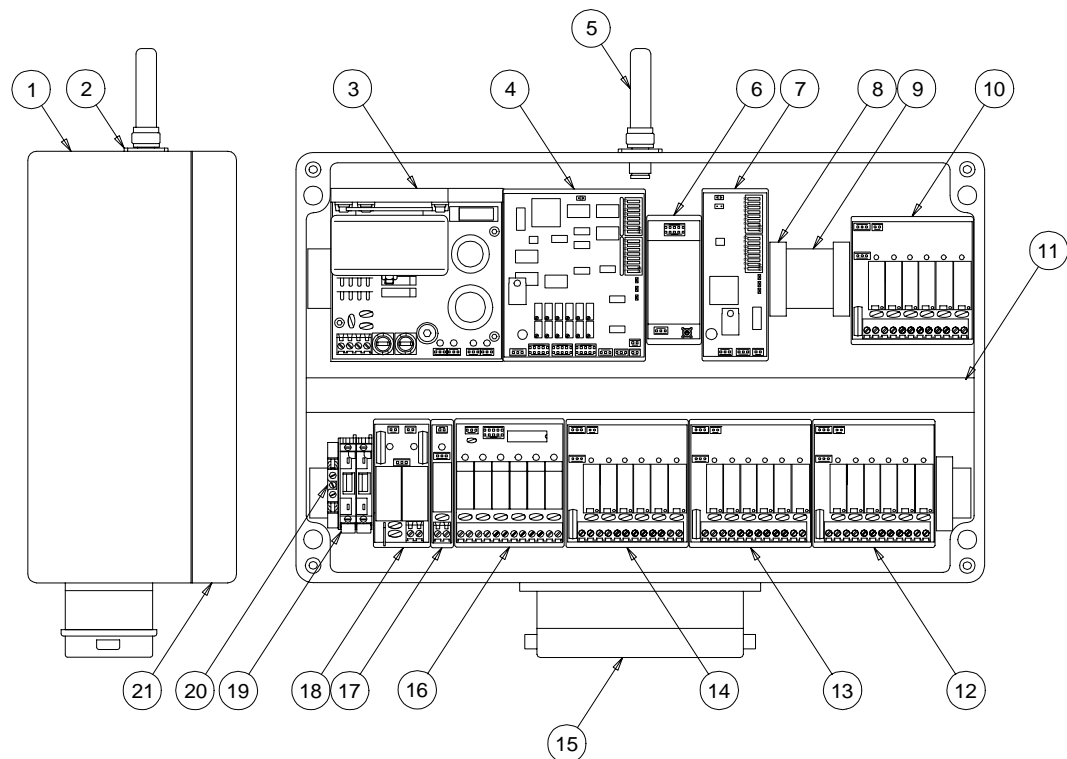

Figure 2.1: PulseStar GA610AS Receiver Layout

- | | |
|--|--|
| 1. Enclosure | 12. AD5S Module (analog to 5 step) for Bridge |
| 2. Miniflex Antenna Base | 13. AD5S Module (analog to 5 step) for Trolley |
| 3. Power Pack (50/110/240vac) | 14. AD5S Module (analog to 5 step) for Hoist |
| 4. Decoder Module | 15. Quick Disconnect Connector Base |
| 5. Miniflex Antenna | 16. REL-6 Module (contains start, option, select A, and select B relays) |
| 6. Standard RF Module | 17. Horn Relay Module |
| 7. Active E-STOP Decoder Module | 18. SNZ Active E-STOP Module |
| 8. End Stop | 19. Line Terminal Block w/Fuse |
| 9. DIN Rail | 20. Ground Terminal Block (PE) |
| 10. AD5S Module (analog to 5 step) for Aux | 21. Enclosure Cover |

GA610AP Receiver

The PulseStar GA610AP receiver is used for proportional 0-10vdc control of variable frequency drives. See Figure 2.2: PulseStar GA610AP Receiver Layout for the location of various components.

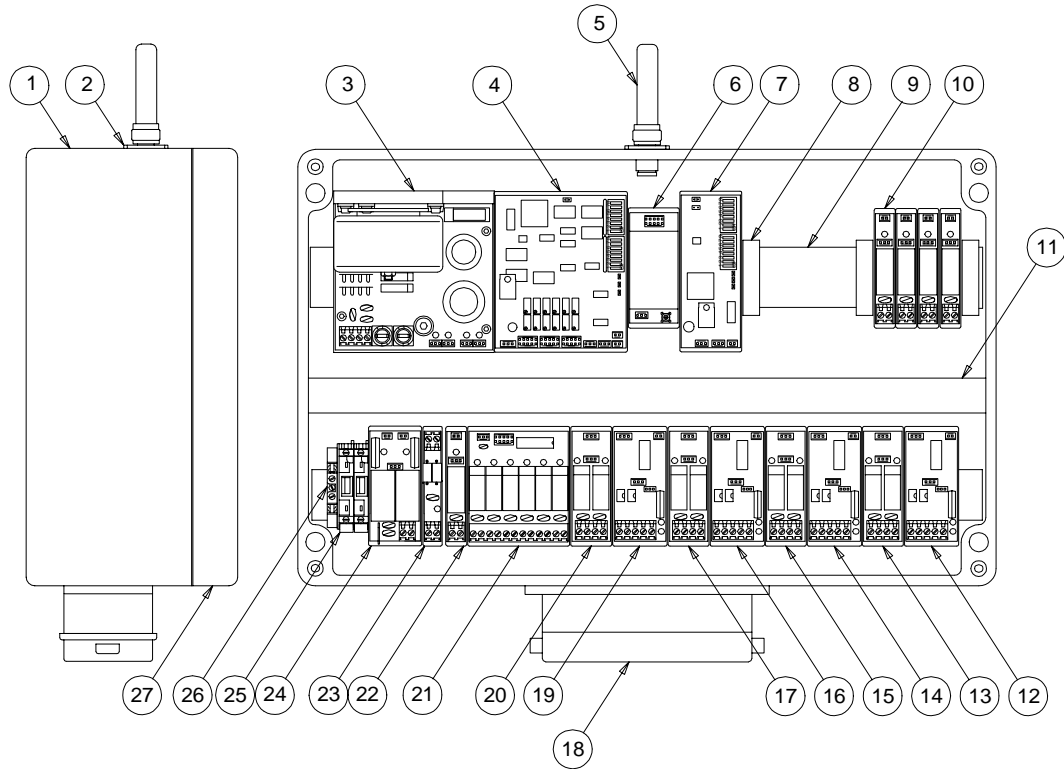

Figure 2.2: PulseStar GA610AP Receiver Layout

- | | |
|--|--|
| 1. Enclosure | 15. RK-1 Module (directional contacts for bridge) |
| 2. Miniflex Antenna Base | 16. SYM-2 Module (0-10vdc for trolley) |
| 3. Power Pack (50/110/240vac) | 17. RK-1 Module (directional contacts for trolley) |
| 4. Decoder Module | 18. Quick Disconnect Connector Base |
| 5. Miniflex Antenna | 19. SYM-2 Module (0-10vdc for hoist) |
| 6. Standard RF Module | 20. RK-1 Module (directional contacts for hoist) |
| 7. Active E-STOP Decoder Module | 21. REL-6 Module (contains start, option, select A, and select B relays) |
| 8. End Stop | 22. Horn Relay Module |
| 9. DIN Rail | 23. EMVS-1 Suppressor Module |
| 10. Safety Relay Module (1 of 4) | 24. SNZ Active E-STOP Module |
| 11. Wire Duct | 25. Line Terminal Block w/Fuse |
| 12. SYM-2 Module (0-10vdc for aux) | 26. Ground Terminal Block (PE) |
| 13. RK-1 Module (directional contacts for aux) | 27. Enclosure Cover |
| 14. SYM-2 Module (0-10vdc for bridge) | |

Installing the PulseStar•610 Receiver



WARNING

- Only authorized personnel are permitted to perform the initial setup or service work. Use only Electromotive Systems parts.
- Do NOT touch any circuit components on the circuit board while the main AC power is on.
- Do NOT change the address code settings in the receiver.
- Do NOT run control wires with power wires.
- Surge Suppressors must be used with all magnetic contactors that are controlled by the PulseStar•610 system.

Assessing the Receiver Enclosure Environment

When you choose a location for the receiver enclosure, consider the following guidelines.

1. The Receiver can be operated on the following power supplies:
 - 50V/110V/240V (+/-20%), AC, Single Phase
2. Ensure that the receiver enclosure will be protected or isolated from:
 - Ambient temperatures outside the range of -18°F to 158°F (-25°C to +70°C). Consult Electromotive Systems if you must exceed this temperature range.
 - Corrosive gases or liquids.
3. As much as possible, ensure that the receiver is not surrounded by metal or other conductive materials that could prevent the miniflex antenna from receiving the transmitter signal. If you are using an external antenna, ensure that it is not surrounded by metal or other conductive materials.

Serial Nameplate

Before you prepare to mount the receiver, locate the serial nameplate. The receiver serial nameplate is typically located on the right hand side of the enclosure. The serial nameplate contains the Electromotive Systems job number, the address code used by the system, and the frequency channel used by the system. **The Electromotive Systems job number is important if you ever need to call Electromotive Systems for service.** When you mount the receiver, ensure that the serial nameplate is visible so that you can easily read the Electromotive Systems job number.

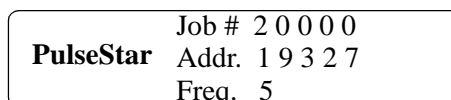

Figure 2.3: Serial Nameplate

Mounting the PulseStar•610 Receiver

Refer to Figure 2.4: Receiver Dimensions for mounting the PulseStar•610 receiver.

1. Determine the mounting position of the receiver.
2. Loosen the screws securing the enclosure cover to the enclosure.
3. Using the dimensions shown in Figure 2.4: Receiver Dimensions, drill holes into the mounting surface. The depth of the hole depends on the type of screw you are using to mount the receiver enclosure. Use an appropriately sized tap to thread the mounting holes, or you can mount the receiver by using screw nuts.
4. Mount the receiver by inserting the screws through each of the mounting holes, and then tighten the mounting screws to the mounting surface.
5. Lay out the wire runs. At a minimum, use #18 AWG for power wiring.

NOTE: *When using the GA610AP receiver shielded cable must be used for connecting the 0-10 volt DC and DC ground control wires from the receiver quick disconnect connector to the variable frequency inverter drive.*

6. If the receiver is to be mounted inside a control panel or enclosure, an external antenna is necessary. Refer to Wiring the PulseStar•610 Receiver or Mounting a Gain Flex Antenna for information on how to properly mount the external antenna.

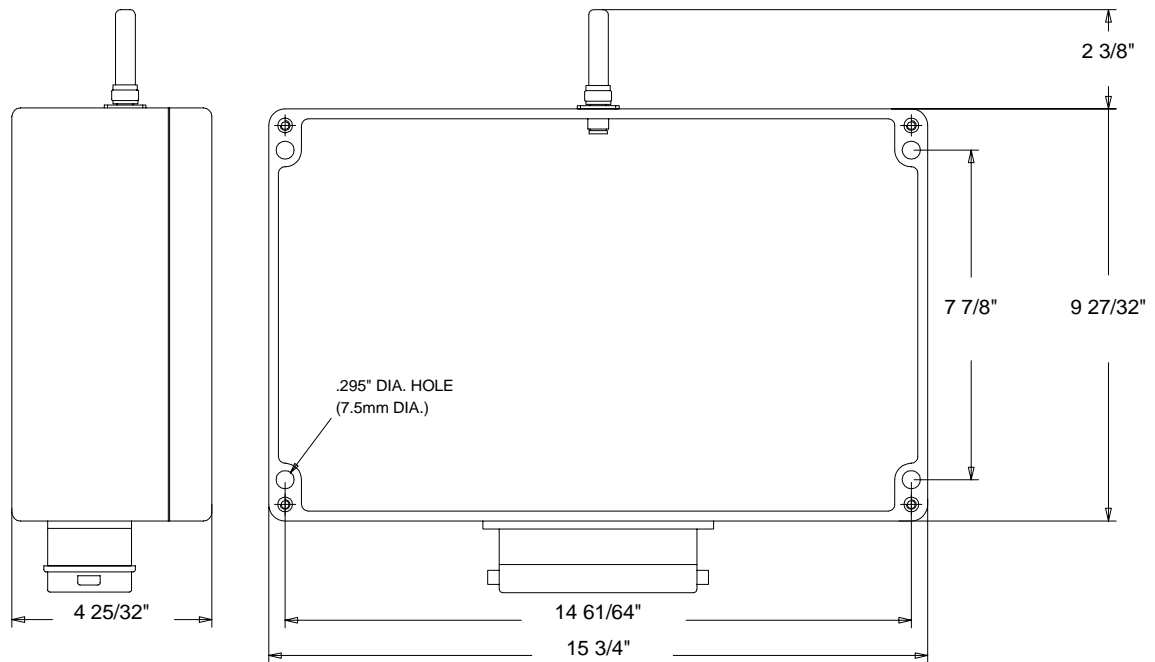

Figure 2.4: Receiver Dimensions

Mounting a Standard External Antenna

In some cases, such as when the receiver is inside a panel enclosure, you may need to connect an external antenna to the PulseStar•610 receiver instead of using the miniflex antenna. Mount the standard external antenna on a metal surface with the same ground as the receiver circuit board. Make sure that the antenna is not surrounded by metal or other conductive materials. For best reception, the antenna should be pointing upward.

NOTE: *Failure to properly install the antenna will result in intermittent operation.*

1. Drill a $\frac{9}{16}$ inch hole through the enclosure.
2. Insert the connector base through the hole so that the antenna side is on the outside, and the base is seated firmly against the enclosure surface. Remove any burrs from the antenna mounting hole and scrape away any paint which may prohibit the antenna base from making ground contact with the enclosure.
3. Assemble the antenna according to Figure 2.5: Standard External Antenna.

1. Antenna Pole
2. Enclosure
3. Antenna Base
4. Antenna Cable

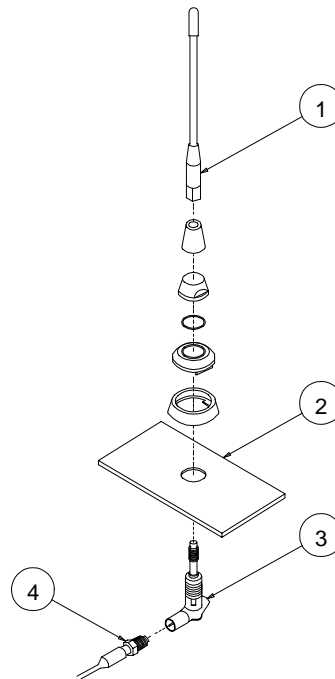

Figure 2.5: Standard External Antenna

4. Screw the antenna pole onto the antenna base.
5. Remove the miniflex antenna mounted on the PulseStar•610 receiver by unscrewing it from the antenna base.
6. Connect the antenna cable connector to the antenna base on the PulseStar•610 receiver housing.
7. Bundle any excess antenna cable by looping the cable, then flatten the cable loop and tighten both ends of the flattened cable with tie wraps or equivalent.

NOTE: *Never run the antenna cable with power or control wiring. Doing so will result in intermittent operation.*

Mounting a Gain Flex Antenna

Some applications require the use of a gain flex antenna. The gain flex antenna can extend the operating range of the PulseStar•610 system up to 300 meters (1000 feet). It is also used with intrinsically safe applications, and applications where a standard antenna is too difficult to mount. Make sure that there are no metallic or other conductive materials within 2 meters (6 feet) radius of the gain flex antenna. These objects will interfere with the reception of the gain flex antenna, and will result in intermittent crane operation. For best reception, the antenna should be pointing upward.

NOTE: *Failure to properly install the antenna will result in intermittent operation.*

Refer to Figure 2.6: Gain Flex Antenna when installing the gain flex antenna.

1. Affix the antenna base of the gain flex antenna to a mounting surface by using the two tie wraps included with the antenna kit. For best reception the antenna base should be mounted vertically with the antenna base pointing upward.

1. Antenna Pole
2. Antenna Base
3. Tie Wrap
4. Antenna Cable

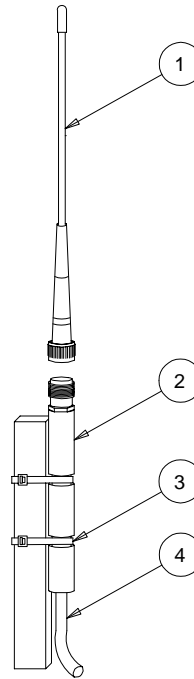

Figure 2.6: Gain Flex Antenna

2. Screw the gain flex antenna pole onto the antenna base.
3. Remove the miniflex antenna mounted on the PulseStar•610 receiver by unscrewing it from the antenna base.
4. Connect the antenna cable connector to the antenna base on the PulseStar•610 receiver housing.
5. Bundle any excess antenna cable by looping the cable, then flatten the cable loop and tighten both ends of the flattened cable with tie wraps or equivalent.

NOTE: *Never run the antenna cable with power or control wiring. Doing so will result in intermittent operation.*

Wiring the PulseStar•610 Receiver



WARNING

- Only authorized personnel are permitted to perform the initial setup or service work. Use only Electromotive Systems parts.
- Do NOT touch any circuit components on the circuit board while the main AC power is on.
- Do NOT change the address code settings in the receiver.
- Do NOT run control wires with power wires.
- Surge Suppressors must be used with all magnetic contactors that are controlled by the PulseStar•610 system.

Quick Disconnect Plug

All Pulsestar•610 receivers are supplied with a 64 pole, 33 wire quick disconnect plug. Both the male and female connector plug modules are numbered alpha-numerically, and these numbers are referenced in the wiring diagrams shown later in this chapter.

The receiver quick disconnect outputs are pre-wired by the factory. Wiring can be changed by the customer to accommodate situations such as different power transformers for each motion. Refer to Figure 2.7: 64 Pin Quick Disconnect Connector Base for the location of the receiver wire termination points.

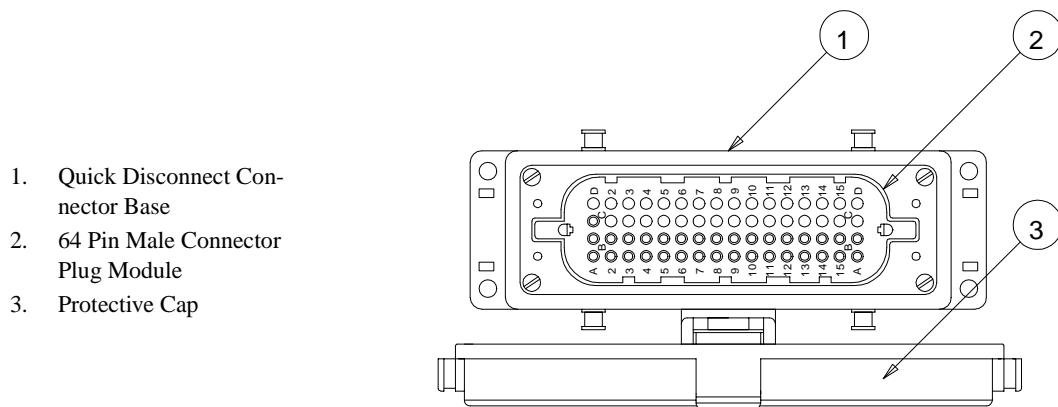

Figure 2.7: 64 Pin Quick Disconnect Connector Base

Terminating Wires to the Female Quick Disconnect Plug

It is the customer's responsibility to terminate the control and power wires from the crane controls to the female quick disconnect plug. The 64 pin female connector plug module requires crimp pin terminations. These pins are provided with the quick disconnect plug hardware.

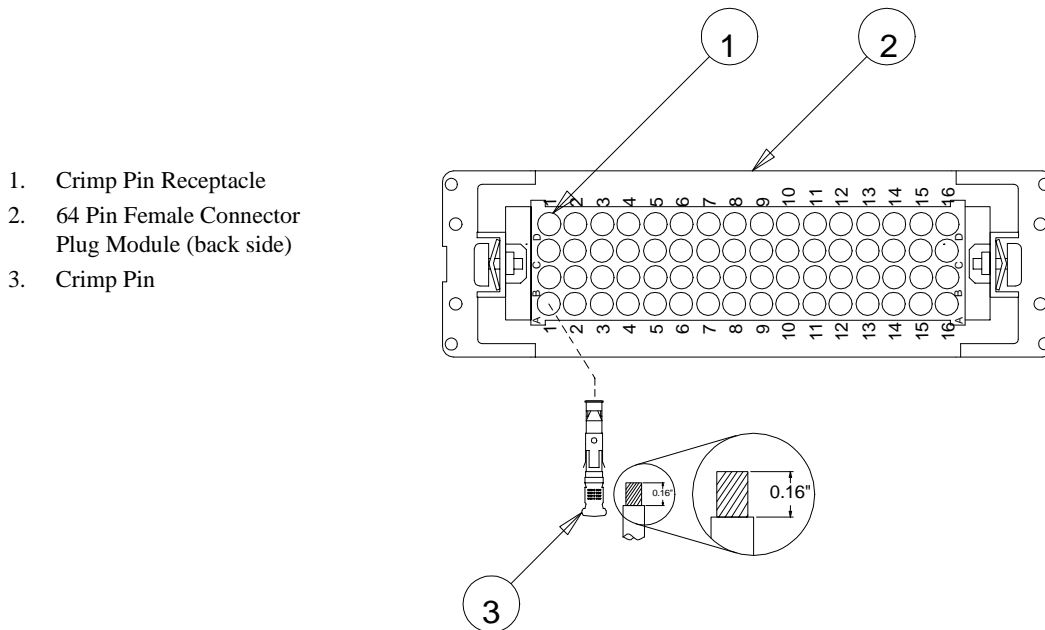

Figure 2.8: 64 Pin Female Connector Plug Module Crimp Pin Insertion

1. Using the wire runs created in the Mounting the PulseStar•610 Receiver section terminate each wire with a crimp pin using standard crimping tool or equivalent. Reference Figure 2.8: 64 Pin Female Connector Plug Module Crimp Pin Insertion for information on removing the correct amount of insulation from the wire.
2. Referencing Figure 2.9: 64 Pin Quick Disconnect Plug Layout remove the 64 pin female connector plug module from the female connector plug housing.
3. Feed the power and control wires through the female plug connector housing PG29 orifice.
4. Referencing the wiring diagrams shown later in this chapter insert the power and control wires appropriately into the back side of the 64 pin female connector plug module. Reference Figure 2.8: 64 Pin Female Connector Plug Module Crimp Pin Insertion for proper crimp pin insertion orientation.
5. Insert the 64 pin female connector plug module into the female connector plug housing and tighten the four retaining screws.
6. Terminate the control wires to crane controls.
7. Install Resistor/Capacitor (RC) type surge absorbers (not MOV type) across the coils of any contactors installed in the crane control circuit which are controlled by the radio control receiver.

NOTE: *Surge suppression is required on all magnetic contactors controlled by the receiver. Uncommanded crane motion and/or serious component damage may occur if surge suppressors are not used.*

Quick Disconnect Plug Housing Orientation

The orientation of the female connector plug housing can be changed to suit the customer's needs. Refer to Figure 2.9: 64 Pin Quick Disconnect Plug Layout for the location of various connector components.

To change the connector housing orientation:

1. Loosen the retaining screws.
2. Separate the 64 pin female connector plug module from the female connector plug housing.
3. Rotate the housing to the appropriate orientation.
4. Re-insert the 64 pin female connector plug module inside the female connector plug housing.
5. Tighten the retaining screws.

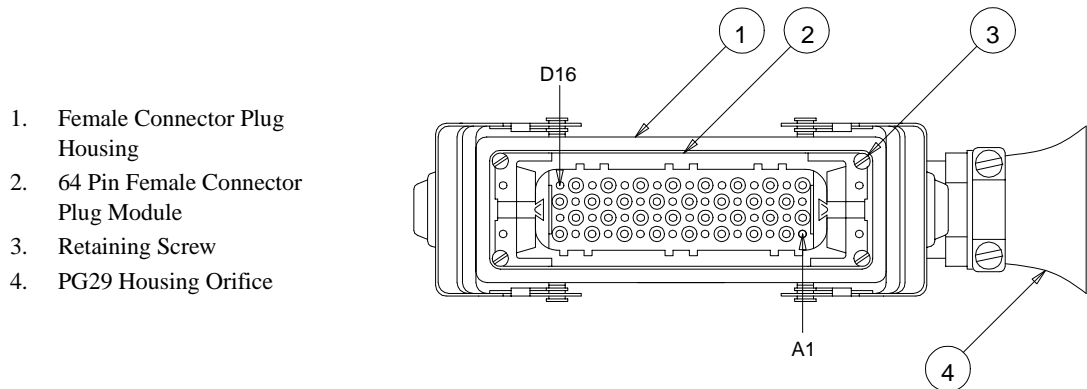

Figure 2.9: 64 Pin Quick Disconnect Plug Layout

PulseStar•610 Receiver Wiring Diagrams

GA610AS Receiver

Figure 2.10: GA610AS Wiring Diagram and Figure 2.11: GA610AS Wiring Diagram shows how to wire the GA610AS receiver.

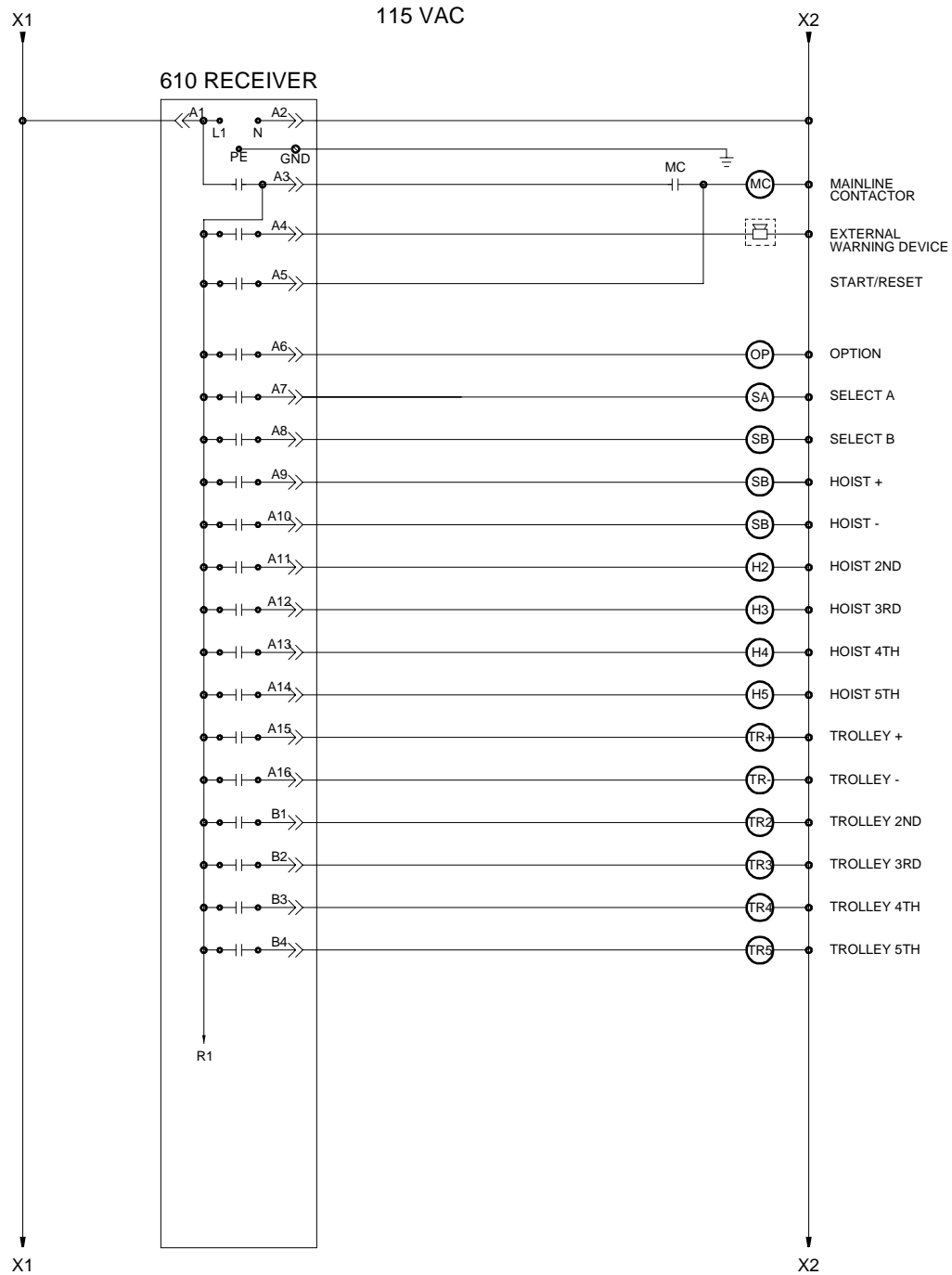

Figure 2.10: GA610AS Wiring Diagram

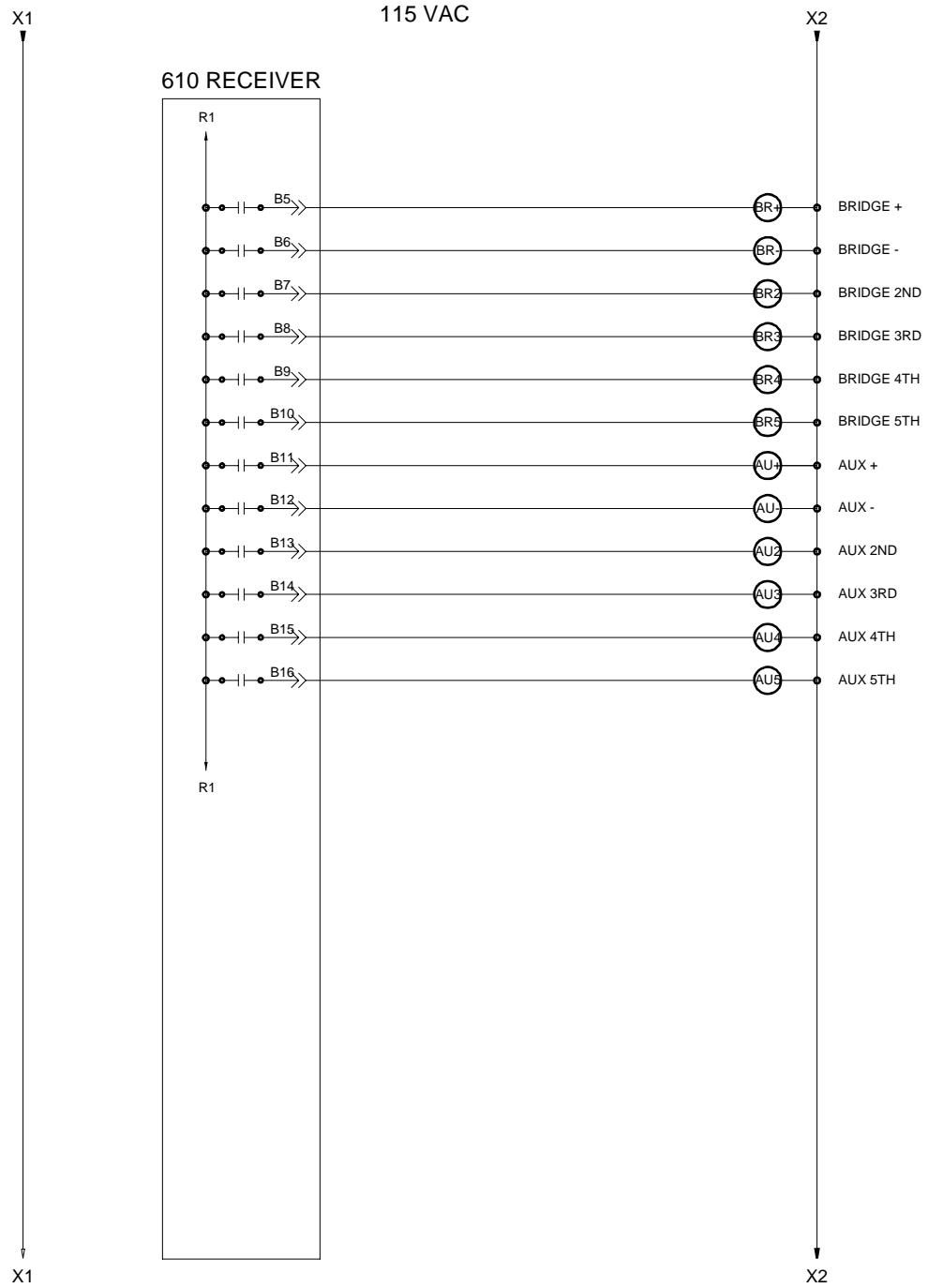

Figure 2.11: GA610AS Wiring Diagram

GA610AS Receiver With Pendant And Isolation Transfer Switch

Figure 2.12: GA610AS Wiring Diagram With Pendant And Isolation Transfer Switch and Figure 2.13: GA610AS Wiring Diagram With Pendant And Isolation Transfer Switch shows how to wire the GA610AS receiver when using a back-up pendant and a PS-21215D isolation transfer switch.

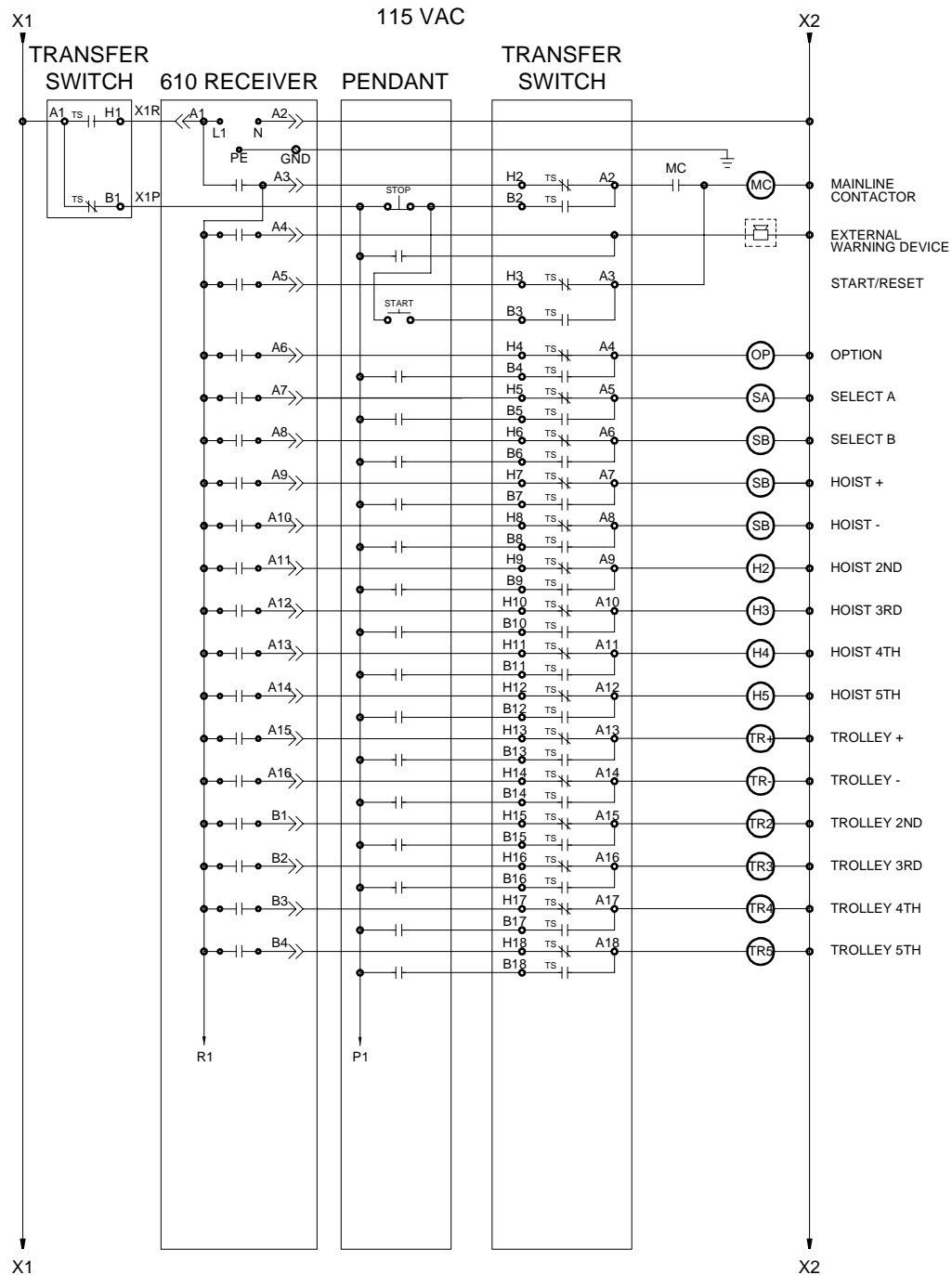

Figure 2.12: GA610AS Wiring Diagram With Pendant And Isolation Transfer Switch

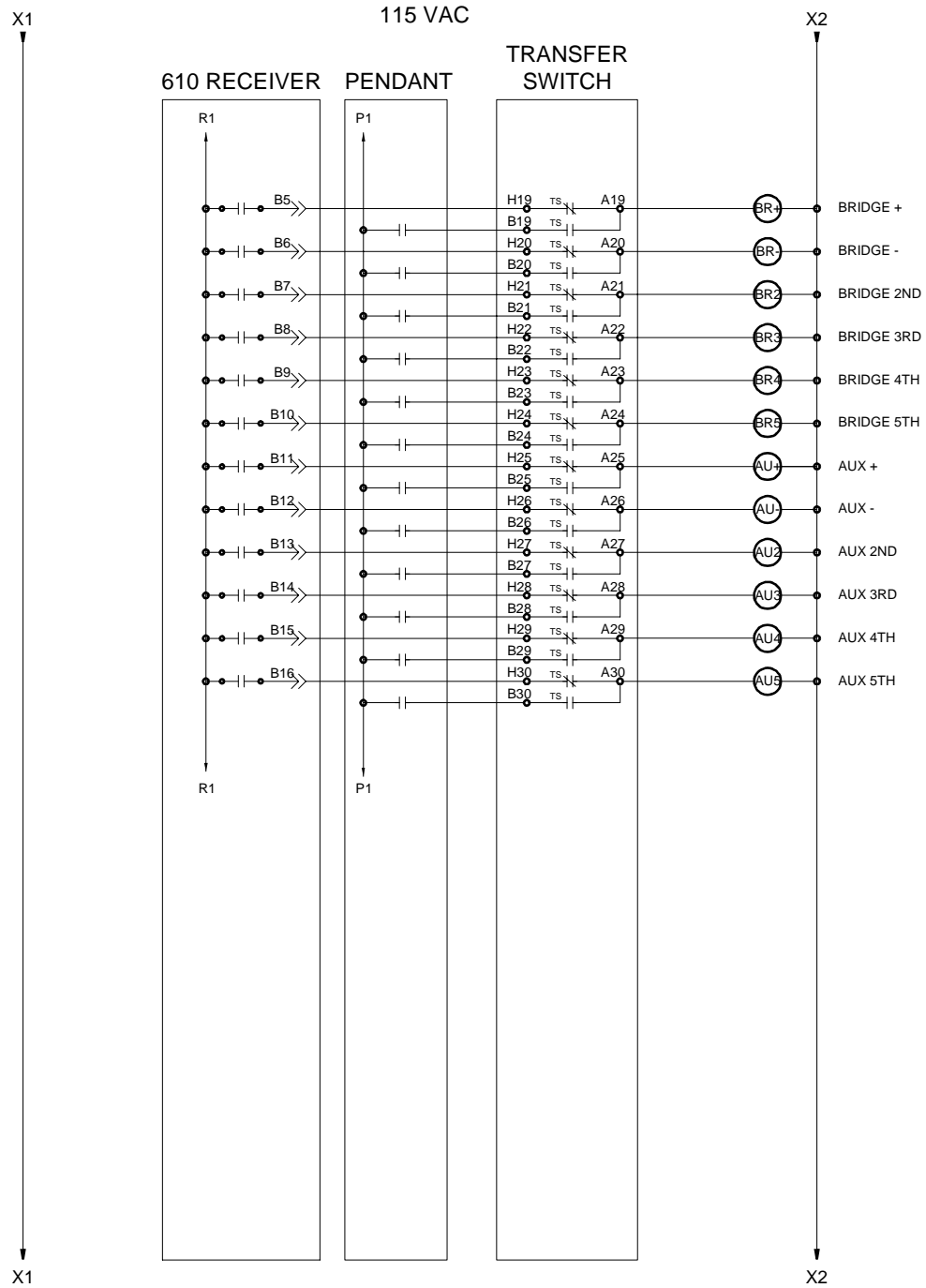

Figure 2.13: GA610AS Wiring Diagram With Pendant And Isolation Transfer Switch

GA610AP Receiver

Figure 2.14: GA610AP Wiring Diagram shows how to wire the GA610AP receiver.

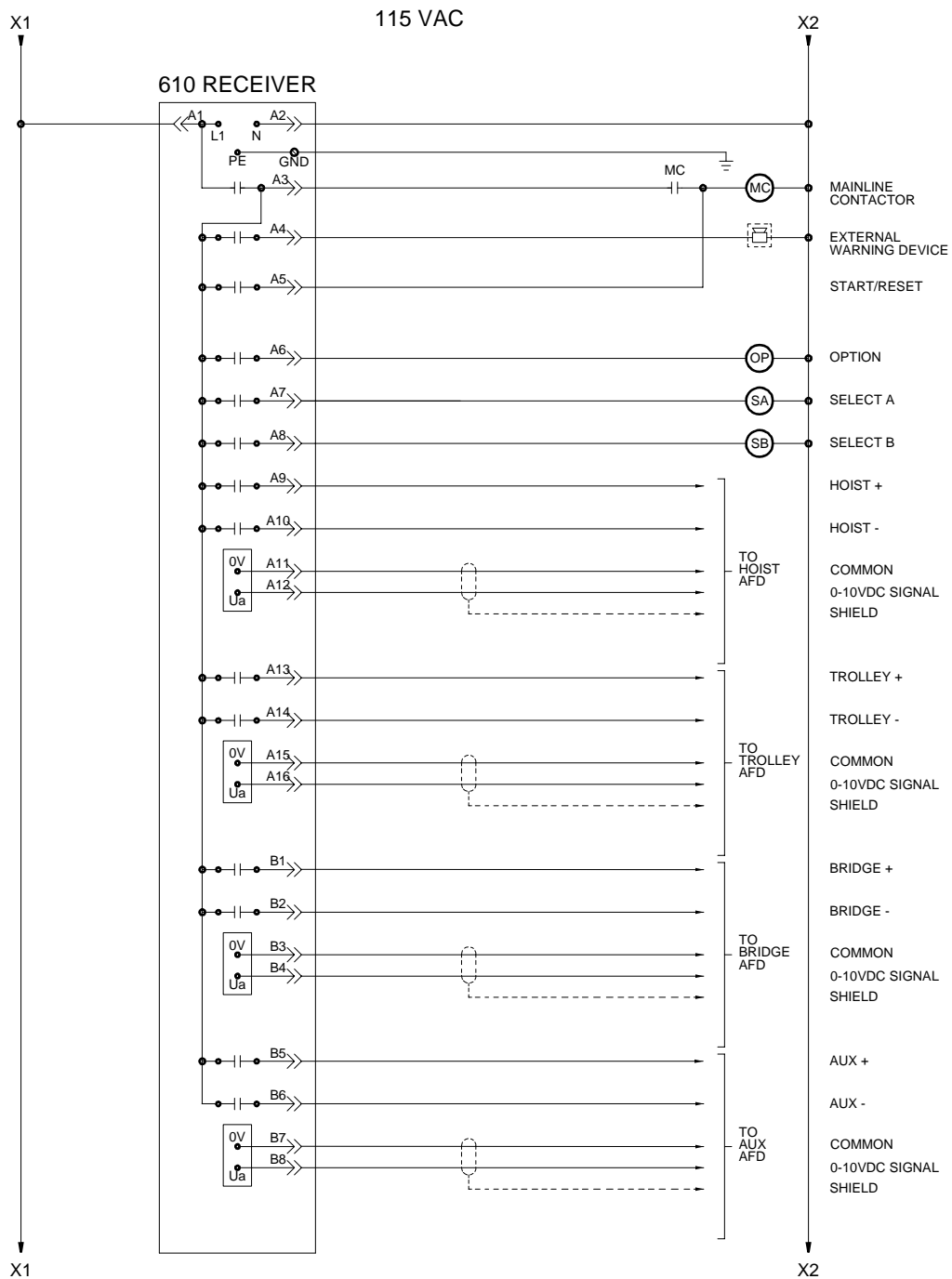

Figure 2.14: GA610AP Wiring Diagram

GA610AP Receiver With Pendant And Isolation Transfer Switch

Figure 2.15: GA610AP Wiring Diagram With Pendant And Isolation Transfer Switch shows how to wire the GA610AP receiver when using a back-up pendant and a PS-21210D isolation transfer switch.

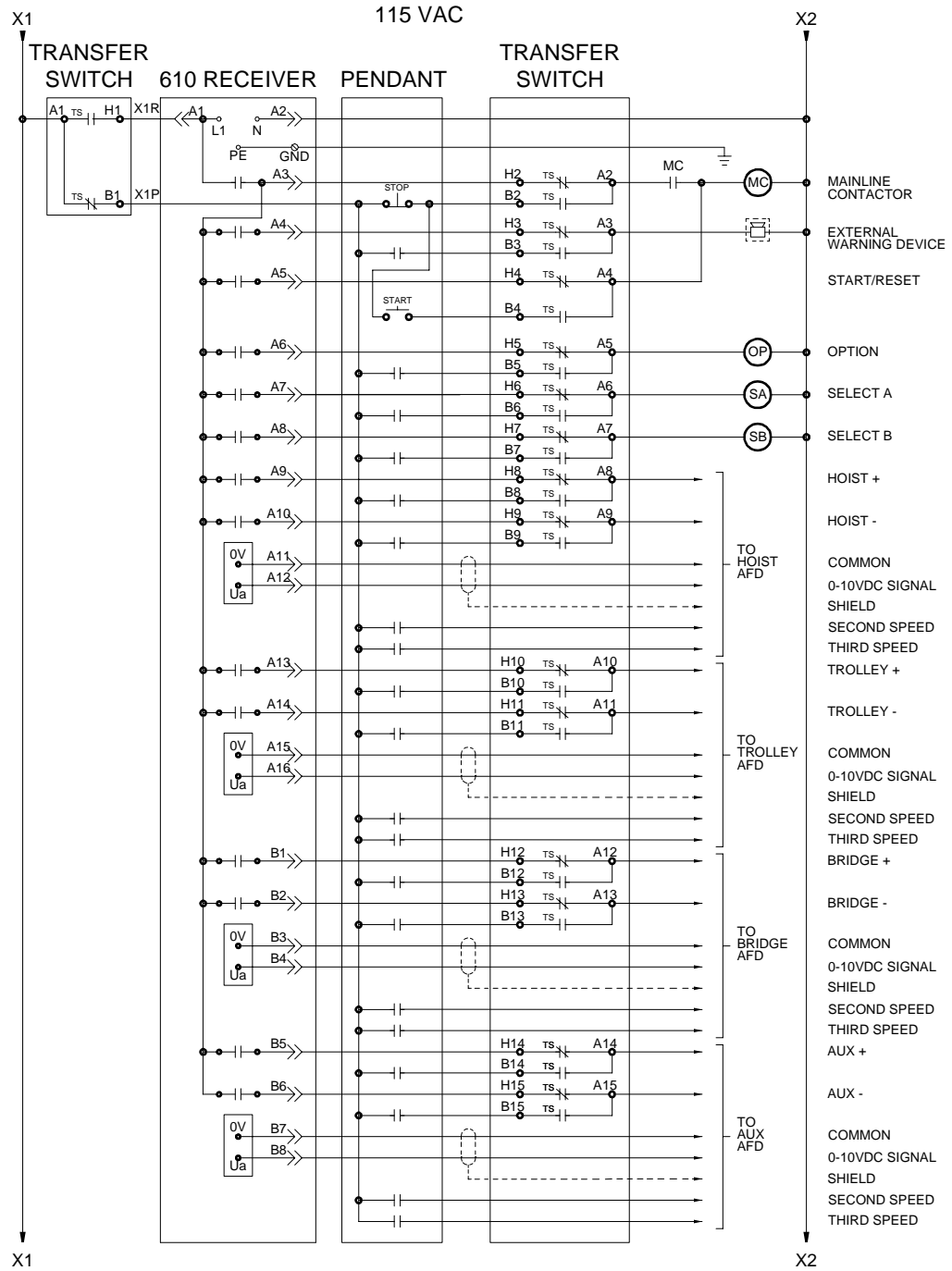

Figure 2.15: GA610AP Wiring Diagram With Pendant And Isolation Transfer Switch

Startup and Test Procedures



WARNING

- Only authorized personnel are permitted to perform testing or service work.
- Make sure the crane is clear of any obstructions, and there is no load on the hook.
- Serious injury or component damage can occur if the PulseStar•610 system is not properly installed and tested.

Pre-operation check list

Before you begin operating the PulseStar•610 system to control your overhead crane, confirm the following check list to ensure that your system is working safely and correctly.

- There is a fully-charged battery in the transmitter.
- The second battery is in the charger being charged at all times. Ensure that the battery charger is plugged into a power source that is not turned off at night with the crane.
- The **Active E-STOP** push-button on the transmitter is pushed in.
- The joysticks and/or paddle levers are in the center (off) position.

Testing the Receiver

As you perform the following startup test, place yourself in front of the PulseStar•610 receiver with the cover off so that you can clearly see each LED and connection. Refer to Figure 2.16: PulseStar•610 Receiver Test Layout for LED and module locations.

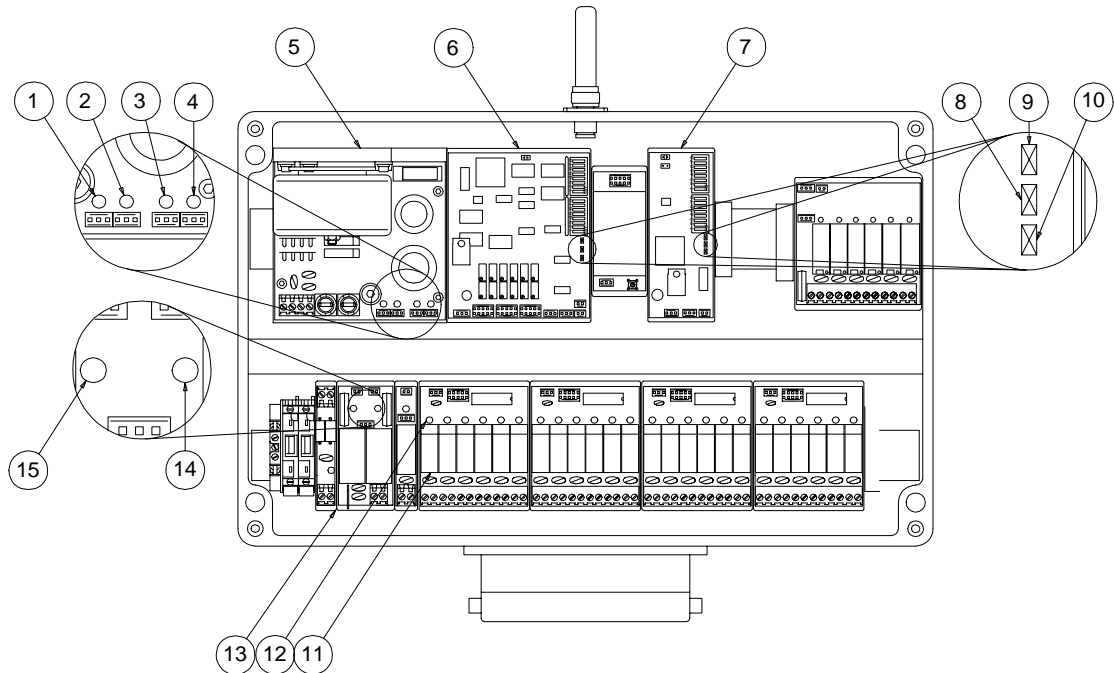

Figure 2.16: PulseStar•610 Receiver Test Layout

- | | |
|---------------------------------|--------------------------------------|
| 1. Power Pack X1 LED | 9. CPU Standby LED |
| 2. Power Pack X2 LED | 10. Active E-STOP LED |
| 3. Power Pack X3 LED | 11. Start Relay |
| 4. Power Pack X4 LED | 12. Start Relay LED |
| 5. Power Pack (50/110/240vac) | 13. SNZ Active E-STOP Module |
| 6. Decoder Module | 14. Active E-STOP Decoder E-STOP LED |
| 7. Active E-STOP Decoder Module | 15. Decoder E-STOP LED |
| 8. Telegram LED | |

1. Turn on the power to the receiver. The CPU Standby LED should flash yellow to indicate that the microprocessor is functioning properly and X1 LED, X2 LED, and X3 LED on the Power Pack should turn on.
2. Insert the key into the ON/OFF key switch on the transmitter and turn to the ON position. A buzzer sounds to indicate the start of a diagnostic test. The diagnostic test checks for the following.
 - The CPU and software is functioning properly.
 - The joysticks and/or paddle levers are in the center (off) position.

The buzzer will sound a second time if the transmitter passes the diagnostic tests.

3. After the diagnostic test the following should occur.
 - The Telegram LED should flash on the Decoder Module and **Active E-STOP** Decoder Module to indicate that the receiver is detecting a valid signal from the transmitter.
4. Pull out the **Active E-STOP** push-button. The following should occur.
 - The X4 LED on the Power Pack should turn on.
 - The Decoder E-STOP LED and **Active E-STOP** Decoder LED on the **Active E-STOP** relay module should turn on.
5. Test the **Active E-STOP** function by pushing in the **Active E-STOP** push-button on the transmitter. The following should occur.
 - The X4 LED on the Power Pack turns off.
 - The Decoder E-STOP LED and **Active E-STOP** Decoder LED on the **Active E-STOP** relay module turn off.
6. Pull the **Active E-STOP** push-button out and press the **START/HORN** push-button on the transmitter. The start relay LED should turn on, the **START** relay should close to activate the mainline contactor, and the **HORN** will sound (when supplied).
7. Activate the joysticks and/or paddle levers to test the crane functions. Confirm that the crane moves appropriately and that the LEDs corresponding to the motion relays or analog output modules turn on. These LED's will be located on the individual motion modules for analog signals, or directly above the discrete relays for digital signals.
8. Activate the **OPTION** function and **SELECTOR** functions (if applicable) to test optional crane function and the A, A+B, B select function. Confirm that the crane moves appropriately and that the LEDs corresponding to the relays or modules turn on when activated.
9. Turn the key switch to OFF. The following should occur.
 - The X4 LED on the power pack turns off.
 - The Decoder E-STOP LED and **Active E-STOP** Decoder LED on the **Active E-STOP** relay module turn off.
 - The Telegram LED on the Decoder Module and **Active E-STOP** Decoder Module turn off.
10. If all transmitter and receiver functions work properly, the system is ready for use.

NOTE: *If you experienced any problems during this test refer to Chapter 4 Troubleshooting PulseStar•610 for help, or call Electromotive Systems.*

Changing the Frequency Channel of the Receiver

Standard RF Module

The standard RF module is capable of receiving one of 16 discrete frequency channels. The frequency channel of the transmitter and receiver are set by Electromotive Systems prior to shipment. Should interferences occur on a particular frequency channel it may be necessary to change the frequency channel of the receiver and transmitter.

NOTE: *Do not change the receiver address code under any circumstances. Contact Electromotive Systems before making any frequency channel changes.*



WARNING

- Do NOT change the address code or frequency channel of the original transmitter that came with your PulseStar•610 system without first contacting Electromotive Systems.
- Do NOT change the address code settings in the PulseStar•610 receiver.
- Do NOT operate two transmitters set with the same frequency channel and address codes as the receiver at the same time.

The PulseStar•610 transmitter and receiver operate over the 400—470 MHz frequency range (70-cm band). There are 16 possible frequencies and 16 corresponding channels available. Figure 2.17: Receiver Frequency Channel Diagram shows each channel, its respective frequency, and the position of the five jumpers according to the diagram for the frequency channel you are setting.

Frequency Channel Considerations

If there are multiple PulseStar radio remote control systems in your facility care should be taken in selecting frequency channels that will operate each system. Although PulseStar systems use a narrow band synthesized carrier frequency, residual or ‘side band’ energy from one system can interfere with other system if the are in close proximity. Using the following guidelines will ensure that you will have trouble-free operation of all your PulseStar systems:

- Select frequency channels that are as far apart from one another as possible. Example: If you have two PulseStar remote radio controls, use frequency channel 0 and frequency channel 15.
- If PulseStar systems are within 50 feet of one another, each system’s frequency channel should be set a minimum of three channels apart from one another.
- If PulseStar systems are within 200 feet of one another, each system’s frequency channel should be set a minimum of two channels apart from one another.

NOTE: *If you are unsure about your application, or are experiencing periodic crane control drop-outs contact Electromotive Systems for assistance.*

Setting the Frequency Channel

1. Remove the receiver cover.
2. Referencing either Figure 2.1: PulseStar GA610AS Receiver Layout or Figure 2.2: PulseStar GA610AP Receiver Layout locate the Standard RF Module inside the receiver.
3. Reference Figure 2.17: Receiver Frequency Channel Diagram to locate the Frequency Channel Jumper Block located on the Standard RF Module.
4. Set the frequency channel jumpers according Figure 2.17: Receiver Frequency Channel Diagram for the appropriate frequency channel. A black box indicates that a jumper should be present in that position. A white box indicates there should be no jumper present in that position.
5. When finished, replace the receiver cover and tighten the four screws.

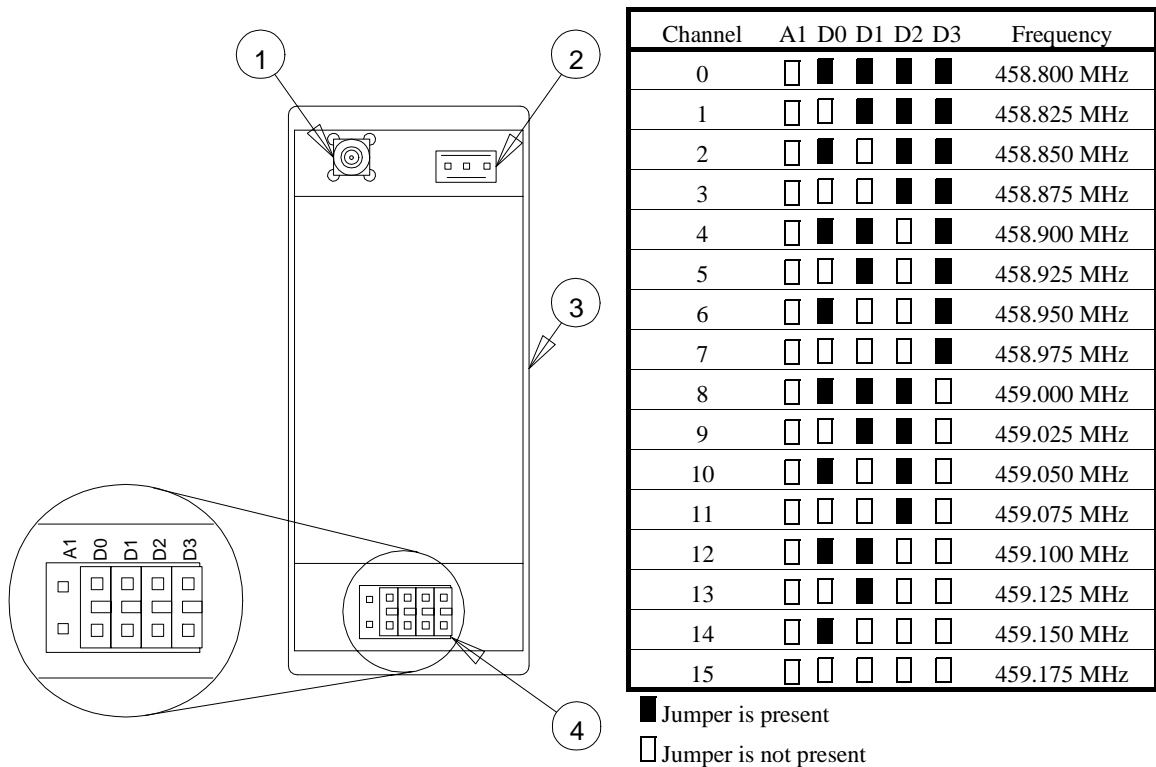

Figure 2.17: Receiver Frequency Channel Diagram

- | | |
|----------------------|-----------------------------------|
| 1. Antenna Connector | 3. Standard RF Module |
| 2. TTL Connector | 4. Frequency Channel Jumper Block |

This page is intentionally left blank.

c h a p t e r **3**

**The PulseStar•610
Transmitter**

This page is intentionally left blank.

Overview

This chapter tells you how to configure and use the PulseStar•610 transmitter. Several types of transmitters are available for use with the PulseStar•610 system. This manual will cover the basic features of each transmitter.

This chapter covers the following information.

- PulseStar•610 Transmitters
- Transmitter Setup
- Start-up and Operation
- Transmitter Options
- Battery and Charger Information

PulseStar•610 Transmitters

There are four types of transmitters which can be used with a PulseStar•610 system. They are:

- NVT belly box transmitter with joysticks
- NVT belly box transmitter with paddle levers
- GLT belly box transmitter with joysticks
- GLT belly box transmitter with paddle levers

NVT Transmitter

The NVT transmitter has a “belly box” design where the operator maneuvers joysticks or paddle levers to control crane motions. The standard NVT joysticks and paddle levers offer proportional speed control without detents. The NVT joystick model contains two dual axis joysticks for up to four motion control. The NVT paddle lever model contains four single axis paddle levers for up to four motion control.

The NVT also has a **SELECTOR** toggle switch for controlling multiple crane motions with one joystick or paddle lever. With the **SELECTOR** toggle switch, the NVT can control up to five crane motions for independent/combined control.

NVT Transmitter Components (Joystick Model)

The NVT joystick transmitter has the following components. Refer to Figure 3.1: NVT Joystick Transmitter Layout to identify parts of the NVT transmitter.

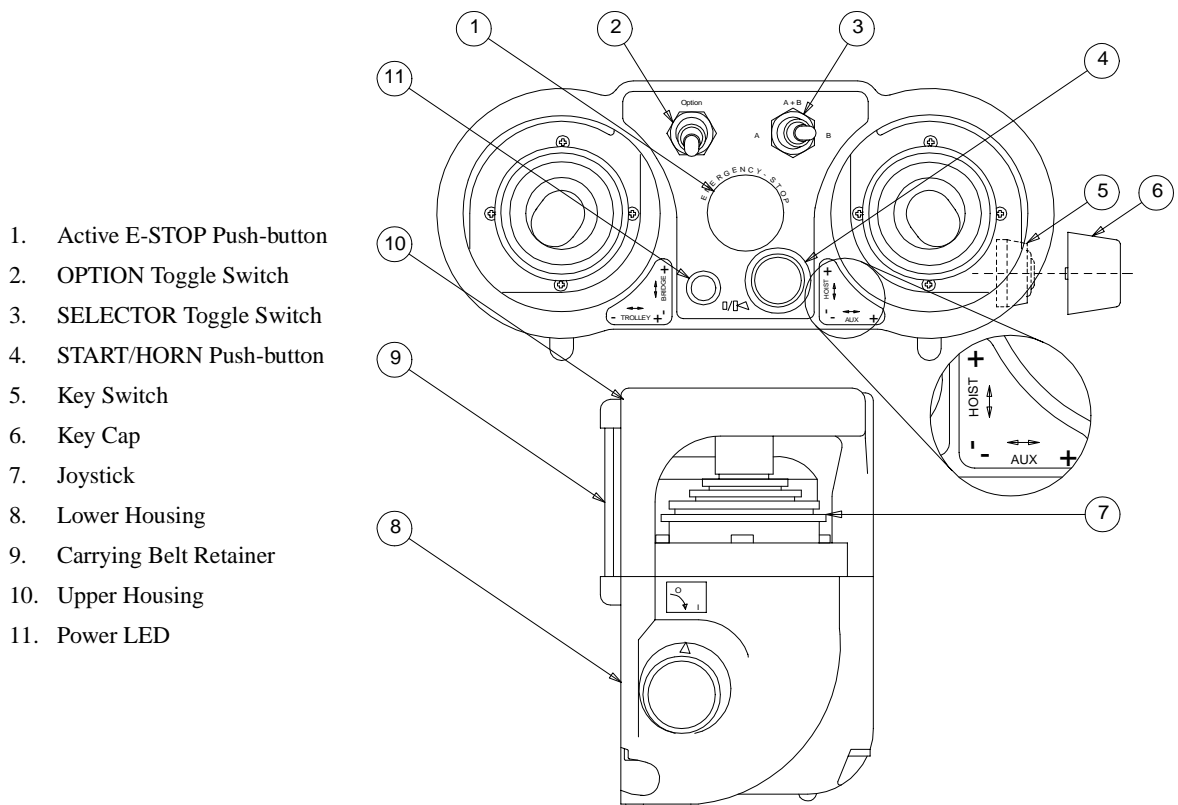

Figure 3.1: NVT Joystick Transmitter Layout

NVT Transmitter Components (Paddle Lever Model)

The NVT paddle lever transmitter has the following components. Refer to Figure 3.2: NVT Paddle Lever Transmitter Layout to identify parts of the NVT transmitter.

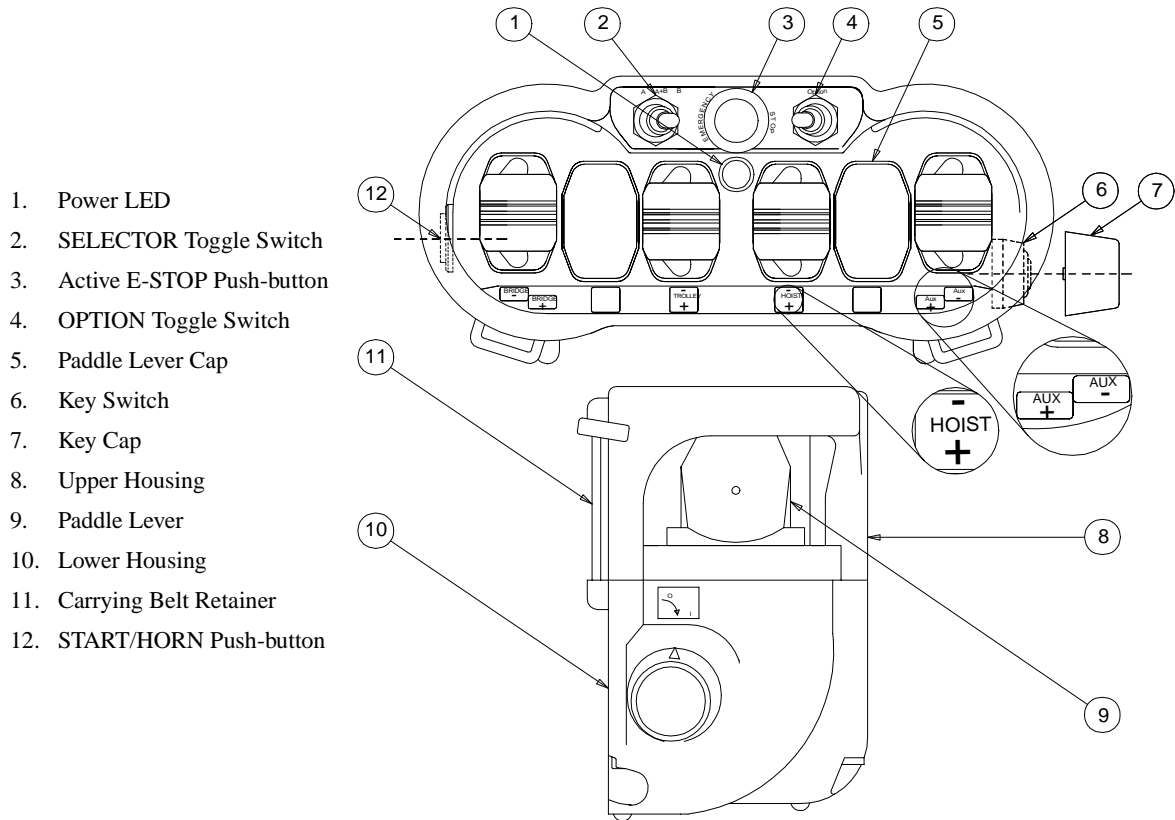

Figure 3.2: NVT Paddle Lever Transmitter Layout

NVT Transmitter Functions

The following describes the basic functionality of the NVT transmitter. Please reference Figure 3.1: NVT Joystick Transmitter Layout or Figure 3.2: NVT Paddle Lever Transmitter Layout for the location of these functions.

START/HORN Push-Button. The **START/HORN** push-button activates the mainline contactor and sounds the horn (when provided). Once the mainline contactor has been turned on, pressing this push-button sounds the horn only (when provided).

Active E-STOP Push-button. Pressing the **Active E-STOP** push-button will turn off the mainline contactor. The **Active E-STOP** push-button must be pulled out for the transmitter to control the crane motions.

NOTE: *The Active E-STOP push-button is for emergency situations only. Do NOT use it as an Off switch. Use the key switch to turn the transmitter on and off.*

Power LED. As soon as the NVT is turned on, this light will flash once. The transmitter then goes through a diagnostic check. If the transmitter passes the diagnostic check the Power LED flashed green. This indicates that the transmitter is powered up.

Key Switch. The key switch turns the transmitter on and off. It only works with the key cap inserted, and the key cap can only be removed while in the OFF position.

Joysticks. The standard NVT joysticks provide stepless proportional speed control without detents of up to four crane motions. The number of motions can be increased by using the **SELECTOR** toggle switch for independent/combined control of cranes or trolley/hoists.

Paddle Levers. The standard NVT paddle lever provide stepless proportional speed control without detents of up to four crane motions. The number of motions can be increased by using the **SELECTOR** toggle switch for independent/combined control of cranes or trolley/hoists.

OPTION Toggle Switch. This switch controls the **OPTION** function connected to the PulseStar•610 receiver (lights, for example). The function will begin when the switch is moved to the On position. The function will continue working until the switch is moved to the Off position.

SELECTOR Toggle Switch. The **SELECTOR** toggle switch allows the operator to control multiple cranes from a single transmitter, or multiple crane motions from a single joystick or paddle lever. When the **SELECTOR** toggle switch is set to A, the transmitter activates the Select A relay inside the receiver. When the **SELECTOR** toggle switch is set to B, the transmitter activates the Select B relay inside the receiver. When the **SELECTOR** toggle switch is set to A+B, both Select A and Select B relays inside the receiver are activated.

NOTE: *The PulseStar•610 receiver provides an A and a B control signal the same way that a pendant station with a rotary A, A+B, B select switch does. The crane controls must have existing A, A+B, B select relay logic in order for independent/combined control from the PulseStar transmitter to work.*

GLT Transmitter

The GLT transmitter has a “belly box” design where the operator maneuvers joysticks or paddle levers to control crane motions. The standard GLT joysticks and paddle levers offer proportional speed control without detents. The GLT joystick model contains two dual axis joysticks for up to four motion control. The GLT paddle lever model contains four single axis paddle levers for up to four motion control.

The GLT also has a **SELECTOR** toggle switch for controlling multiple crane motions with one joystick or paddle lever. With the **SELECTOR** toggle switch, the GLT can control up to five crane motions for independent/combined control.

GLT Transmitter Components (Joystick Model)

The GLT joystick transmitter has the following components. Refer to Figure 3.3: GLT Joystick Transmitter Layout to identify parts of the GLT transmitter.

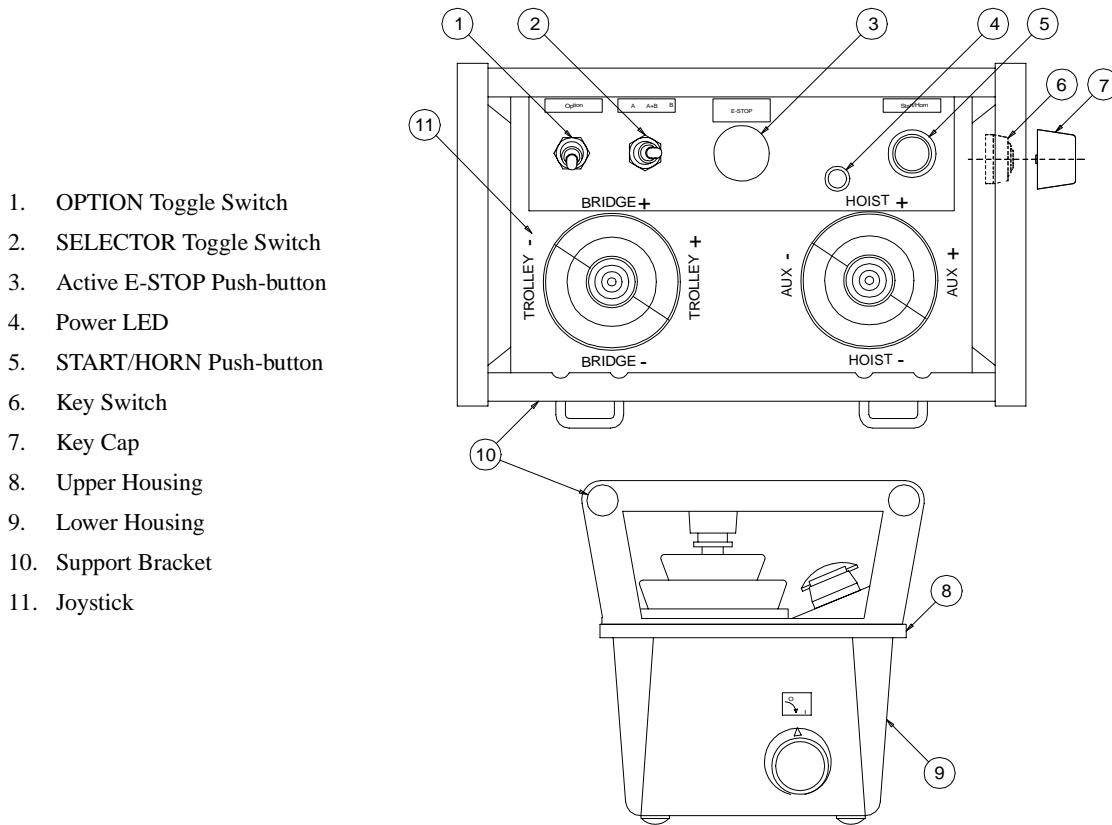

Figure 3.3: GLT Joystick Transmitter Layout

GLT Transmitter Components (Paddle Lever Model)

The GLT paddle lever transmitter has the following components. Refer to Figure 3.4: GLT Paddle Lever Transmitter Layout to identify parts of the GLT transmitter.

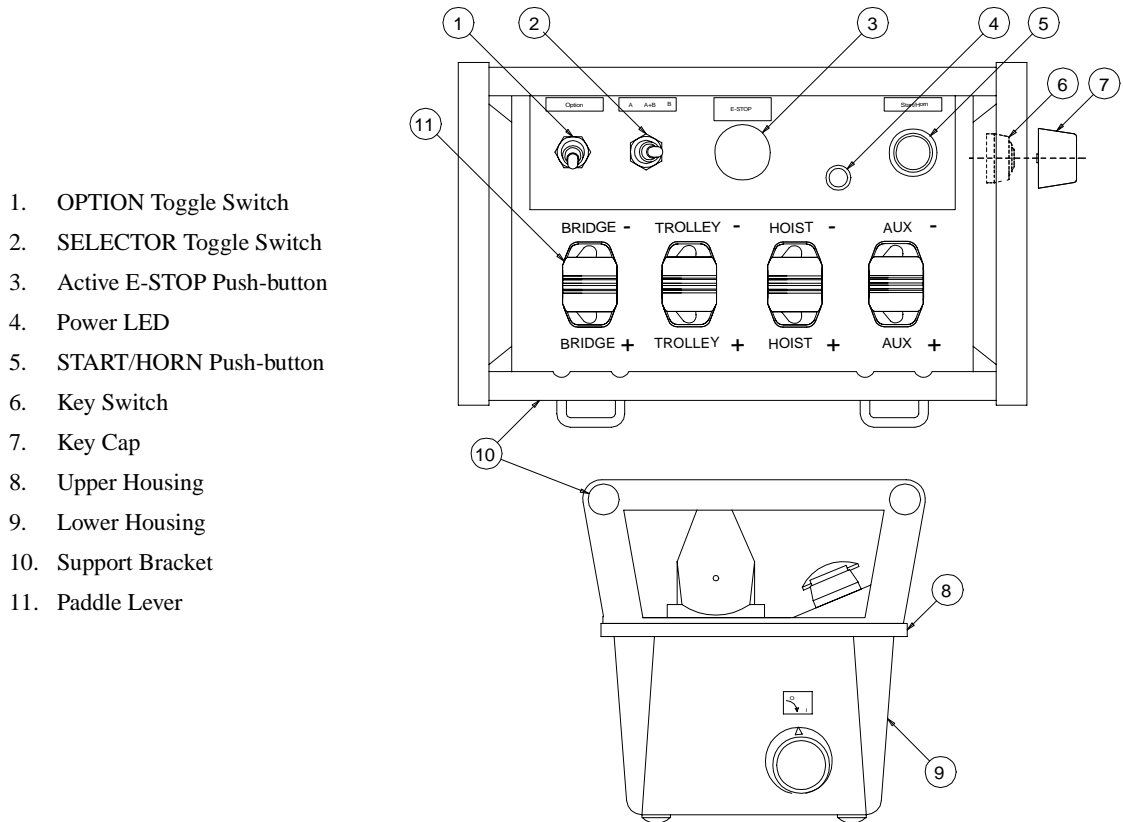

Figure 3.4: GLT Paddle Lever Transmitter Layout

GLT Transmitter Functions

The following describes the basic functionality of the GLT transmitter. Please reference for the location of these functions.

START/HORN Push-button. The **START/HORN** push-button activates the mainline contactor and sounds the horn (when provided). Once the mainline contactor has been turned on, pressing this push-button sounds the horn only (when provided).

Active E-STOP Push-button. Pressing the **Active E-STOP** push-button will turn off the mainline contactor. The **Active E-STOP** push-button must be pulled out for the transmitter to control the crane motions.

NOTE: *The Active E-STOP push-button is for emergency situations only. Do NOT use it as an Off switch. Use the key switch to turn the transmitter on and off.*

Power LED. As soon as the GLT is turned on, this light will flash once. The transmitter then goes through a diagnostic check. If the transmitter passes the diagnostic check the Power LED flashed green. This indicates that the transmitter is powered up.

Key Switch. The key switch turns the transmitter on and off. It only works with the key cap inserted, and the key cap can only be removed while in the OFF position.

Joysticks. The standard GLT joysticks provide stepless proportional speed control without detents of up to six crane motions. This number of motions can be increased by using the **SELECTOR** toggle switch for independent/combined control of cranes or trolley/hoists.

Paddle Levers. The standard GLT paddle lever provide stepless proportional speed control without detents of up to four crane motions. The number of motions can be increased by using the **SELECTOR** toggle switch for independent/combined control of cranes or trolley/hoists.

OPTION Toggle Switch. This switch controls the **OPTION** function connected to the PulseStar•610 receiver (lights, for example). The function will begin when the switch is moved to the On position. The function will continue working until the switch is moved to the Off position.

SELECTOR Toggle Switch. The **SELECTOR** toggle switch allows the operator to control multiple cranes from a single transmitter, or multiple crane motions from a single joystick or paddle lever. When the **SELECTOR** toggle switch is set to A, the transmitter activates the Select A relay inside the receiver. When the **SELECTOR** toggle switch is set to B, the transmitter activates the Select B relay inside the receiver. When the **SELECTOR** toggle switch is set to A+B, both Select A and Select B relays inside the receiver are activated.

NOTE: *The PulseStar•610 receiver provides an A and a B control signal the same way that a pendant station with a rotary A, A+B, B select switch does. The crane controls must have existing A, A+B, B select relay logic in order for independent/combined control from the PulseStar transmitter to work.*

Transmitter Setup

This section covers how to set up a PulseStar•610 transmitter.

Transmitter Address Code and Frequency Channel

This section explains how to set the address code and frequency channel of the PulseStar•610 transmitter. The PulseStar system address code and frequency channel are configured at the factory. Changes to the address code or frequency channel should be done **ONLY** if you are setting up a spare or replacement transmitter, or directed to do so by Electromotive Systems.



WARNING

- Do NOT change the address code or frequency channel of the original PulseStar•610 transmitter that came with your PulseStar•610 system without first contacting Electromotive Systems.
- Do NOT change the address code settings in the receiver.
- Do NOT operate two transmitters set with the same frequency channel and address code as the receiver at the same time.

Serial Nameplate

The transmitter serial nameplate is located on one of the side walls of the PulseStar•610 transmitter battery cavity. The serial nameplate contains the Electromotive Systems job number, the address code used by the system, and the frequency channel used by the system. **The Electromotive Systems job number is important if you ever need to call Electromotive Systems for service.** Please have this information available when contacting Electromotive Systems.

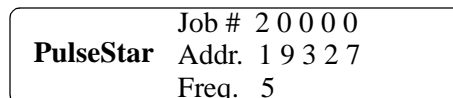

Figure 3.5: Serial Nameplate

Setting the Address Code and Frequency Channel of a Transmitter



CAUTION

Before working on the transmitter, remove the battery.

Before setting the address code and frequency channel of the transmitter, ensure you first know the address code and frequency channel of the receiver it is going to control. This information can be found by locating the serial nameplate on the PulseStar•610 receiver. Refer to the Serial Nameplate section in chapter 2 for the location of the receiver serial nameplate.

1. Make sure the transmitter is off. Remove the key to be sure.
2. Remove the battery from the transmitter, refer to Battery and Charger Information later in this chapter.
3. Access the inside of the PulseStar•610 transmitter by removing the four screws which hold the upper housing and lower housing together.
4. Locate the two blocks of address code DIP switches on the transmitter coder board, and the frequency channel jumper block on the RF module inside the PulseStar•610 transmitter.

Determining the Address Code

Refer to Figure 3.7: NVT, GLT, Coder Board Layout for the location of the address code dip switches.

The address code is a 16 bit binary number which is assigned to each PulseStar system. This code ensures that no other PulseStar system or other radio controlled device can accidentally operate the crane. The address code number on the serial nameplate is a decimal equivalent to the binary code assigned to the system. To determine the binary code of your PulseStar system you can do one of the following:

- Using a calculator with decimal to binary conversion, enter the decimal address code number from the serial nameplate on the receiver. Then convert this number to it's binary equivalent.
- Record the 16 address code switch positions inside the receiver. All switches are either 'on' or 'off'. Always read the switches with the numbering and lettering right side up, from left to right, and with switch number one being on the left.
- Consult Electromotive Systems for information concerning your address code.
- Referencing Figure 3.6: Address Switch Chart use the following formula.

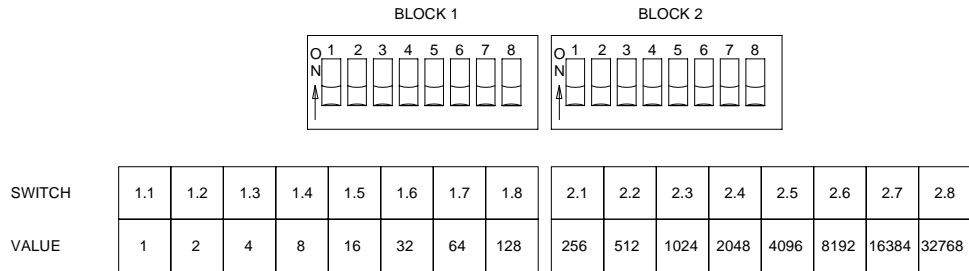

Figure 3.6: Address Switch Chart

1. Write down the transmitter address code.
2. Using the above chart find the largest value that can be subtracted from the address code.
3. Subtract the value from the code.
4. Next to the value write down the corresponding switch number.
5. Repeat steps 1 through 4 until you get a final value of zero.
6. All switches that are listed next to values used should be placed in the on position. All switches that are not listed are to be placed in the off position.

EXAMPLE:

The address code is 32518.

$$\begin{array}{r}
 32518 \\
 - 16384 \text{ Switch 2.7 On} \\
 \hline
 16134 \\
 - 8192 \text{ Switch 2.6 On} \\
 \hline
 7942 \\
 - 4096 \text{ Switch 2.5 On} \\
 \hline
 3846 \\
 - 2048 \text{ Switch 2.4 On} \\
 \hline
 1798 \\
 - 1024 \text{ Switch 2.3 On} \\
 \hline
 774 \\
 - 512 \text{ Switch 2.2 On} \\
 \hline
 262 \\
 - 256 \text{ Switch 2.1 On} \\
 \hline
 6 \\
 - 4 \text{ Switch 1.3 On} \\
 \hline
 2 \\
 - 2 \text{ Switch 1.2 On} \\
 \hline
 0
 \end{array}$$

Once you have the correct address code information you can configure the transmitter to work with the existing receiver.

Setting the Address Code

Reference Figure 3.7: NVT, GLT, Coder Board Layout for changing the address for the transmitter.



WARNING

- Do NOT change the address code or frequency channel of the original PulseStar•610 transmitter that came with your PulseStar•610 system without first contacting Electromotive Systems.
- Do NOT change the address code settings in the receiver.
- Do NOT operate two transmitters set with the same frequency channel and address code as the receiver at the same time.

1. Position the address code switches so that the numbering and lettering is right side up.
2. Locate switch 1.1 on the left most block of the address code switches. This switch is the first bit of the binary address code.
3. Set each switch to either 'on' or 'off' according the binary address code information.
4. If you do not have to set the frequency channel you can now close the transmitter by mating the lower and upper halves and inserting the four screws for the transmitter.

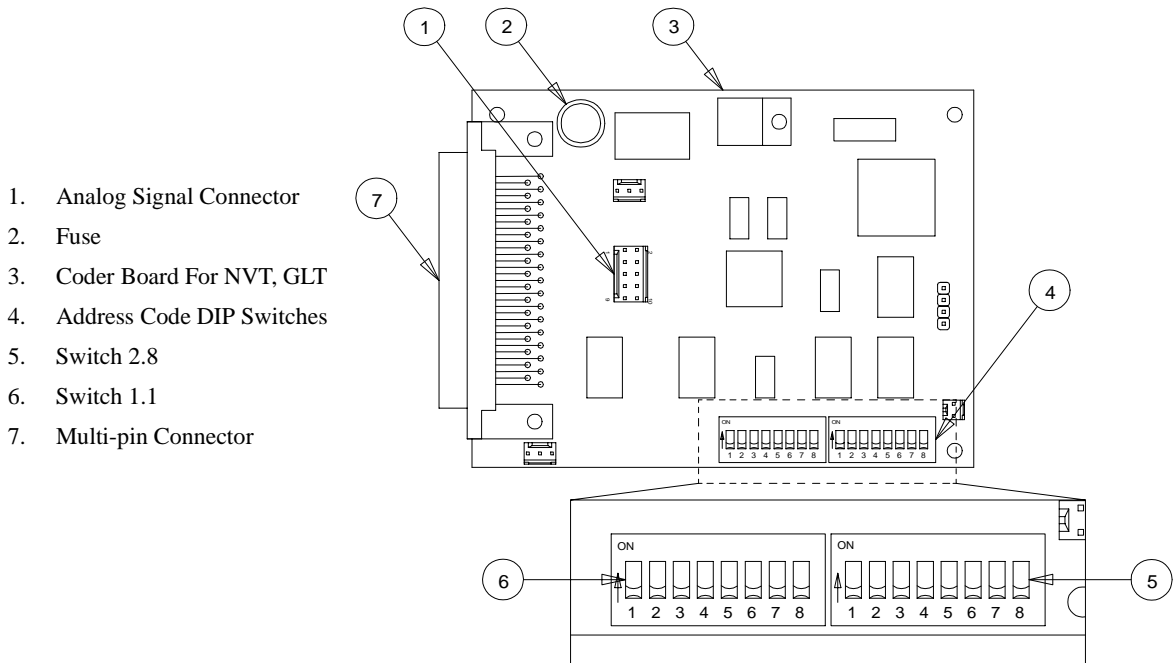

Figure 3.7: NVT, GLT, Coder Board Layout

Frequency Channel Considerations

If there are multiple PulseStar radio remote control systems in your facility care should be taken in selecting frequency channels that will operate each system. Although PulseStar systems use a narrow band synthesized carrier frequency, residual or 'side band' energy from one system can interfere with other system if the are in close proximity. Using the following guidelines will ensure that you will have trouble-free operation of all your PulseStar systems:

- Select frequency channels that are as far apart from one another as possible. Example: If you have two PulseStar remote radio controls, use frequency channel 0 and frequency channel 15.
- If PulseStar systems are within 50 feet of one another, each system's frequency channel should be set a minimum of three channels apart from one another.
- If PulseStar systems are within 200 feet of one another, each system's frequency channel should be set a minimum of two channels apart from one another.

NOTE: *If you are unsure about your application, or are experiencing periodic crane control drop-outs contact Electromotive Systems for assistance.*

Setting the Frequency Channel

The frequency channel of the transmitter must be set to the frequency channel of the receiver it is going to control. The transmitter and receiver operate over the 400–470 MHz frequency range (70-cm band). There are 16 possible frequency channels. Figure 3.8: Frequency Diagram shows the transmitter RF Module, and each channel, its respective frequency, and the position of the five jumpers.

1. Locate the RF Module inside the transmitter.
2. Locate the Frequency Channel Jumper Block on the RF Module. Position the transmitter so that the A1 jumper position is on your left-hand side.
3. Set the frequency jumpers according to the diagram for the desired frequency. A black box indicates that a jumper should be present in that position. A white box indicates there should be no jumper present in that position.
4. When finished, close the transmitter by mating the lower and upper halves and inserting the four screws for the transmitter.

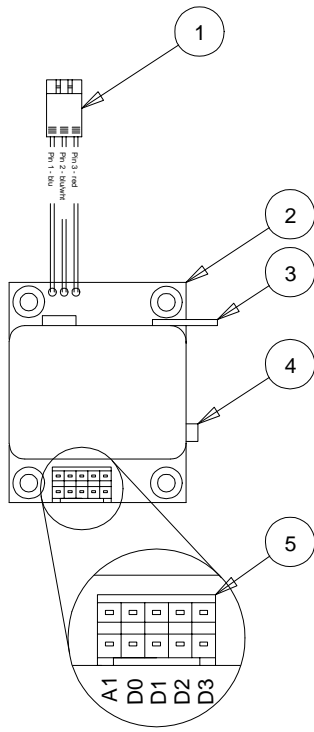

Channel	A1	D0	D1	D2	D3	Frequency
0	■	■	■	■	■	458.800 MHz
1	■	□	■	■	■	458.825 MHz
2	■	■	□	■	■	458.850 MHz
3	■	□	□	■	■	458.875 MHz
4	■	■	■	□	■	458.900 MHz
5	■	□	■	□	■	458.925 MHz
6	■	■	□	□	■	458.950 MHz
7	■	□	□	□	■	458.975 MHz
8	■	■	■	■	□	459.000 MHz
9	■	□	■	■	□	459.025 MHz
10	■	■	□	■	□	459.050 MHz
11	■	□	□	■	□	459.075 MHz
12	■	■	■	□	□	459.100 MHz
13	■	□	■	□	□	459.125 MHz
14	■	■	□	□	□	459.150 MHz
15	■	□	□	□	□	459.175 MHz

■ Jumper is present
□ Jumper is not present

Figure 3.8: Frequency Diagram

- | | |
|---------------------|-----------------------------------|
| 1. TTL Connector | 4. Antenna Connector |
| 2. RF Module | 5. Frequency Channel Jumper Block |
| 3. Ground Connector | |

Start-up and Operation

Holding the Transmitter

Before using the PulseStar•610 transmitter, refer to the following information on how to hold the PulseStar•610 transmitter the correct way.



WARNING

To make sure that you are oriented correctly in relation to the directional push-buttons, paddle levers or joysticks. Hold the transmitter as shown.

NVT Transmitter

Please refer to Figure 3.9: NVT Transmitter Orientation on how to properly hold the NVT transmitter.

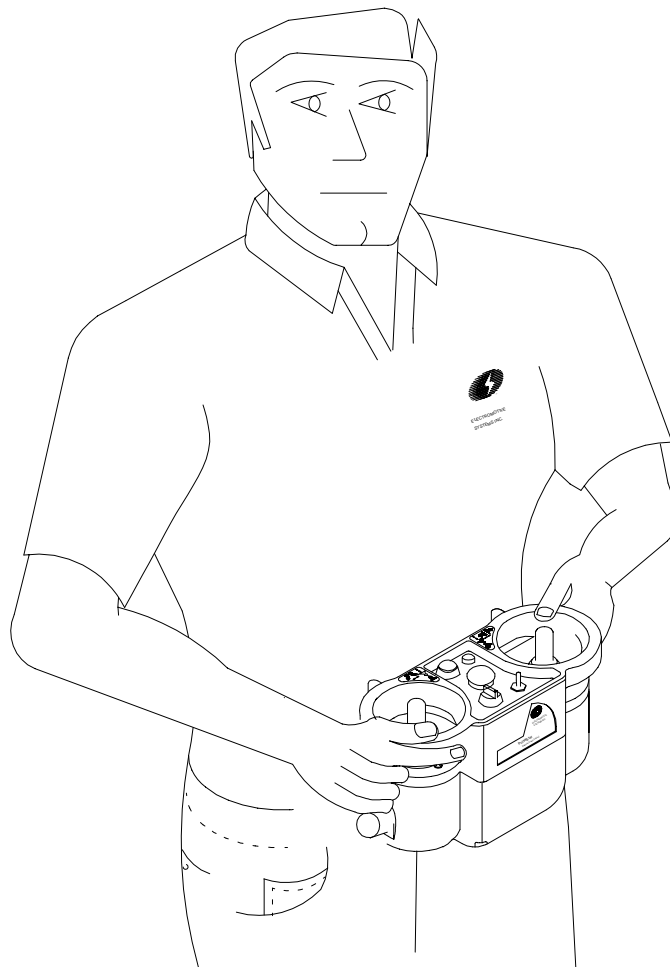

Figure 3.9: NVT Transmitter Orientation

GLT Transmitter

Please refer to Figure 3.10: GLT Transmitter Orientation on how to properly hold the GLT transmitter.

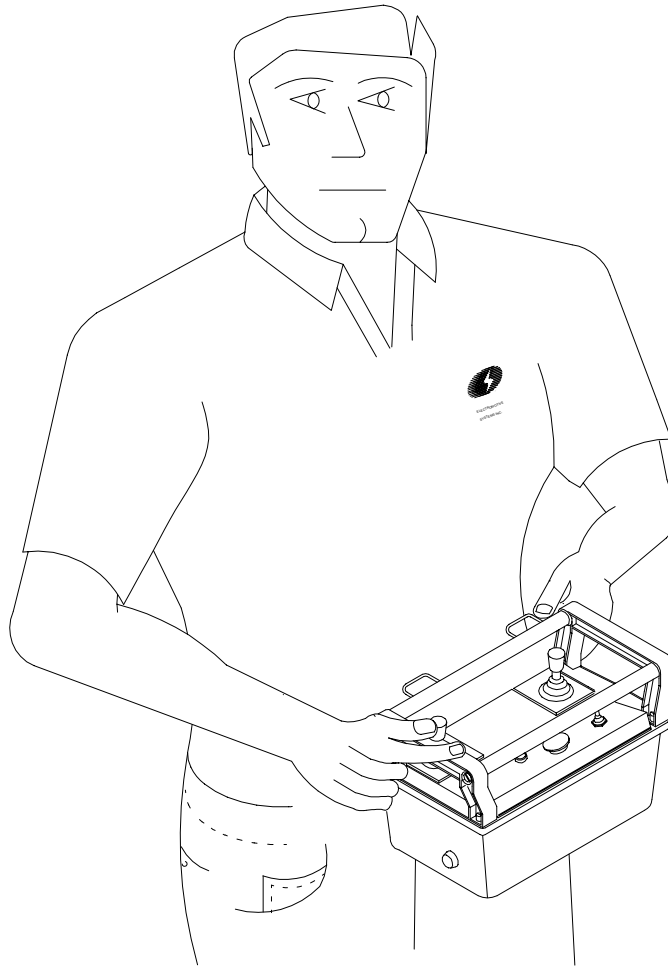

Figure 3.10: GLT Transmitter Orientation

Start-up

Refer to the appropriate transmitter layout figure shown in the PulseStar•610 Transmitters section for the location of the various functions on the PulseStar•610 transmitter. To start the PulseStar•610 transmitter:

1. Make sure that there is a charged battery in the transmitter.
2. Make sure the **Active E-STOP** push-button is pressed in.
3. Make sure all joysticks or paddle levers are in the center (off) position.
4. Insert the key into the transmitter ON/OFF key switch and turn to the ON position. The power LED flashes to indicate power is on. The transmitter will emit two sounds. The first sound indicates that the transmitter is going through the diagnostic check. The second sound indicates that the transmitter has passed the diagnostic check.
5. Pull out the **Active E-STOP** push-button and press the **START/HORN** push-button to provide power to the mainline contactor.

The transmitter is now ready for use.

Emergency Stop

For all emergency situations, push in the **Active E-STOP** push-button. To restart, pull out the **Active E-STOP** push-button and press the **START/HORN** push-button.

When the PulseStar•610 battery voltage drops below approximately 8 volts, a buzzer will sound inside the transmitter. At the end of the 30 second period, the transmitter will automatically shut itself off and places the receiver in **Safe Mode**. This blocks all crane motion commands.

Using the Joysticks or Paddle Levers

All joysticks and paddle levers have a spring return to the center (off) position. Locate the transmitter label which corresponds to the joystick or paddle lever function you wish to operate. Deflect the joystick or paddle lever in the direction you want the crane motion to move according to the label. If the crane motion is more than one speed, the further you deflect the joystick or paddle lever from its center position, the faster the crane motion will move. To stop the crane motion(s) simply return the joystick or paddle lever to the center (off) position.

NOTE: *For all joysticks deflecting the joystick to the right and away from your body represents the motion in the “+” direction. For all paddle levers deflecting the paddle lever toward your body represents the motion in the “+” direction. This is important to know when wiring the receiver to the crane controls.*

Using the Option Toggle Switch

The PulseStar•610 transmitter is provided with an **OPTION** toggle switch. Turn the **OPTION** toggle switch on to activate the device, if any, which is connected to the **OPTION** relay inside the PulseStar•610 receiver. The **OPTION** toggle switch is maintained and will remain in the ON position until placed back into the OFF position.

Using the SELECTOR Toggle Switch

The PulseStar•610 transmitter is provided with a **SELECTOR** toggle switch which controls the independent or combined control of main and aux hoists, two trolley/hoists, or two cranes. When the **SELECTOR** toggle switch is set to A, the transmitter sends a signal which closes **SELECTOR** relay Select A inside the receiver. When the **SELECTOR** toggle switch is set to B, the transmitter sends a signal which closes **SELECTOR** relay Select B inside the receiver. When the **SELECTOR** toggle switch is set to A+B, both Select A and Select B **SELECTOR** relays close inside the receiver.

NOTE: *The PulseStar•610 receiver provides an A and a B control signal the same way that a pendant station with a rotary A, A+B, B select switch does. The crane controls must have existing A, A+B, B select relay logic in order for independent/combined control from the PulseStar transmitter to work.*

Shutting Off the Transmitter

When you are finished using the transmitter, turn the key switch to OFF. The mainline contactor will drop out. Remove the key from the key switch and take it with you to prevent unintended use.

Transmitter Options

The following are some of the more common options which are available with the PulseStar•610 transmitter. If you have any questions about the functionality of your PulseStar•610 system contact Electromotive Systems.

Spare Transmitter

Spare transmitters can be used in the event that the primary transmitter becomes lost or damaged. One transmitter is used as the main crane control and the other is designated as a spare. Only one transmitter is active at any given time.

NOTE: *If both transmitters are set to the same address code and frequency channel and both transmitters are turned on, the receiver will go into safe mode.*

Battery and Charger Information

Removing and Inserting the Battery From the NVT Transmitter

To remove or insert the battery from the NVT transmitter, refer to Figure 3.11: NVT Transmitter Battery Removal.

Removal: Push the battery toward the spring-loaded contacts. Tilt the battery away from the housing until the battery pops out of the compartment.

Insertion: Place the battery in the battery cavity at an angle, with the end containing the gold plated contacts facing the spring-loaded contacts. Push battery into the battery cavity and against the spring loaded contacts until the battery can be placed flush against the battery cavity wall. The battery should now be securely positioned inside the battery cavity.

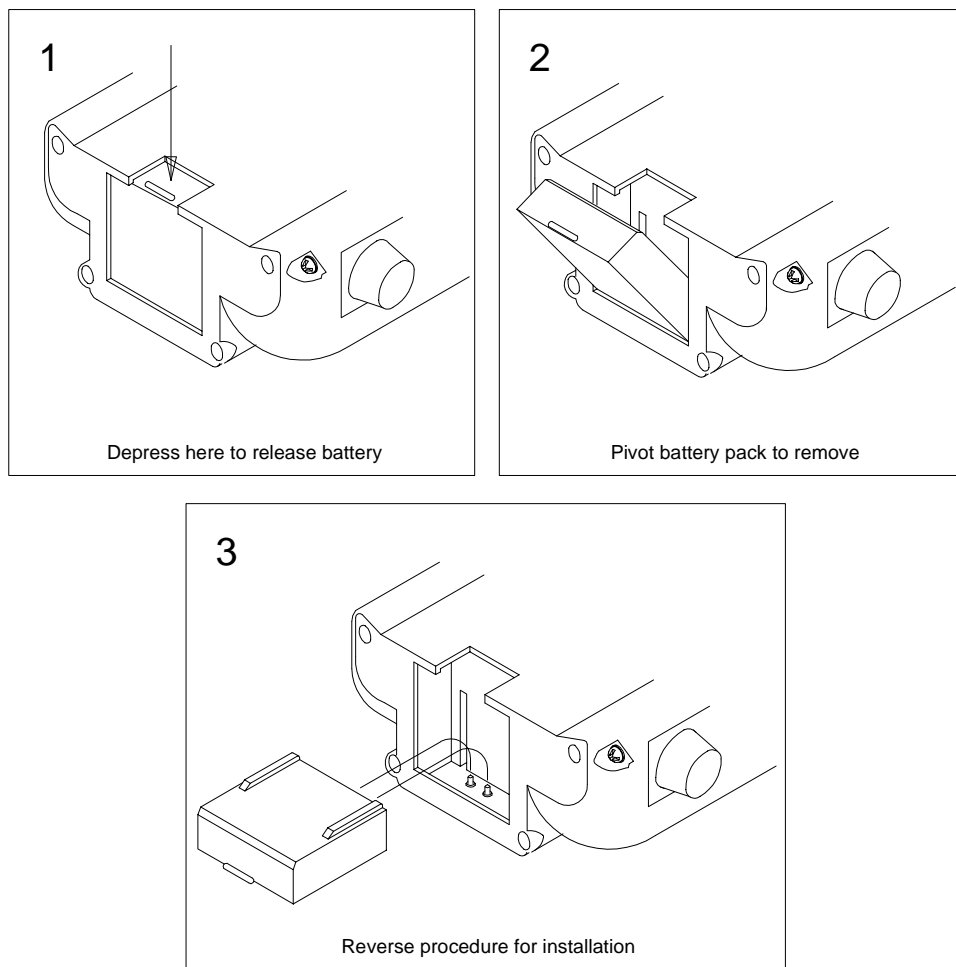

Figure 3.11: NVT Transmitter Battery Removal

Removing and Inserting the Battery From the GLT Transmitter

To remove or insert the battery from the GLT transmitter, refer to Figure 3.12: GLT Transmitter Battery Removal.

Removal: Push the battery tab toward the battery. Pivot the battery away from the housing until the battery pops out of the compartment.

Insertion: Locate the two battery hinges on the battery. They are opposite the battery tab. Line up the battery hinges with the corresponding hinge guides in the battery cavity wall of the transmitter. Place the battery, hinge side first, into the battery cavity and slide the battery hinges into the hinge guides. Slowly press downward on the battery until the battery tab locks into place.

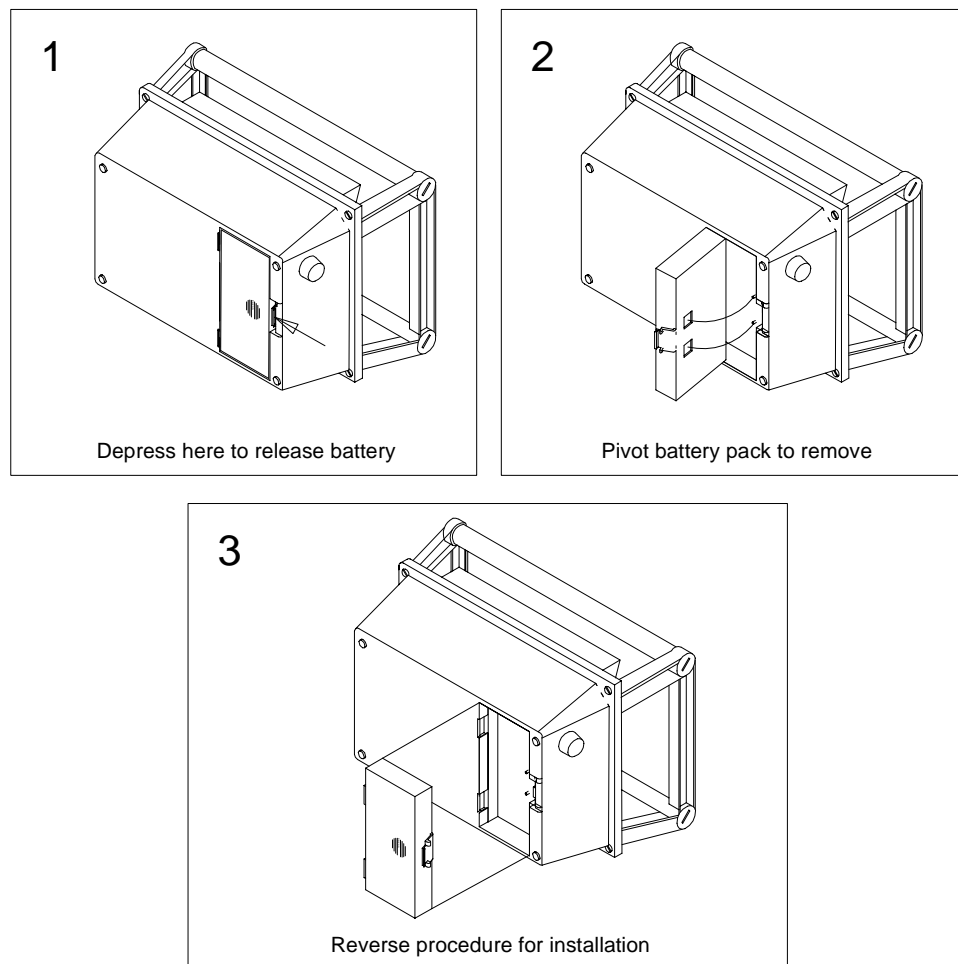

Figure 3.12: GLT Transmitter Battery Removal

Charging the Battery

The PulseStar battery charger is designed for 115/230VAC and plugs into a regular wall outlet. Please refer to Figure 3.13: Battery Charger for NVT Transmitters and Figure 3.14: Battery Charger for GLT Transmitters for charger layout.

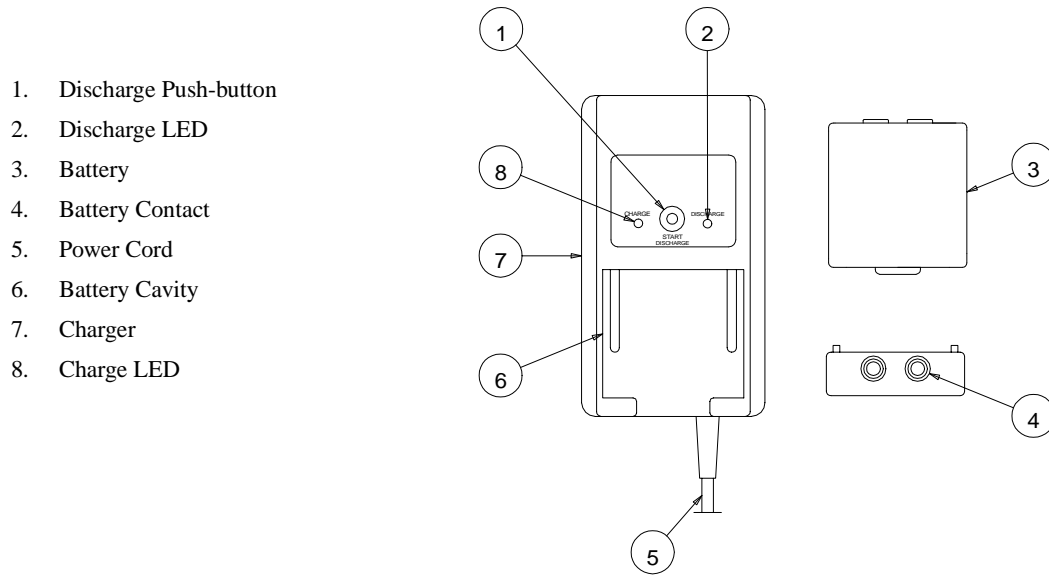

Figure 3.13: Battery Charger for NVT Transmitters

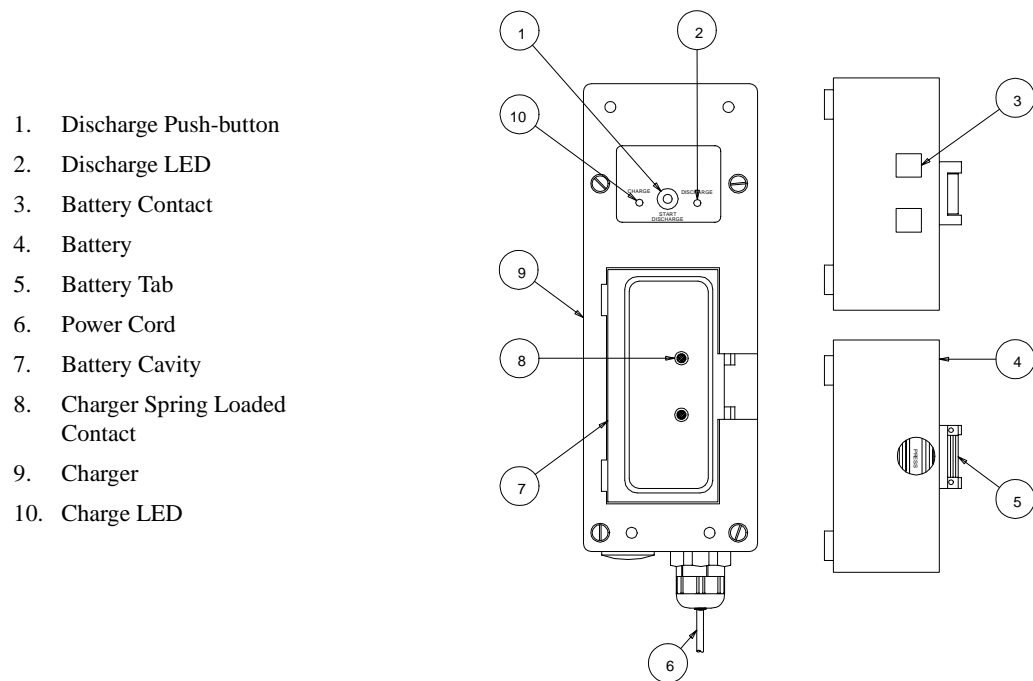

Figure 3.14: Battery Charger for GLT Transmitters

Discharge Charger

Insert the battery into the charger. The green charge LED emits a steady light to indicate that the battery is being charged. Press the red Start Discharge push-button. The green charge LED turns off, and the red discharge LED turns on. The battery will now fully discharge. Once the battery is fully discharged, the red discharge LED will turn off, and the green charge LED will turn on. The green charge LED emits a steady light to indicate that the battery is being charged.

The processor in the charger checks the capacity of the battery until the battery is fully charged. The maximum charging time is four hours. When the battery is fully charged, the green LED begins to flash. Leave the battery in the charger until needed to ensure it is fully-charged.

The following table summarizes battery information for NVT transmitters.

Charging Time	4 hours (from fully discharged)
Operation Time	7–10 hours continuous
Type	Nickel Metal Hydrite; 9.6 Volts, 750 milliampere hours
Maximum number of charges	Approximately 800 times

The following table summarizes battery information for GLT transmitters.

Charging Time	4 hours (from fully discharged)
Operation Time	12-14 hours continuous
Type	Nickel Cadmium; 9.6 Volts, 1000 milliampere hours
Maximum number of charges	Approximately 800 times

All charger and battery contacts are gold-plated to provide superior contact. Batteries and chargers are IP65-rated. The mechanical design of the battery case and the battery pocket ensures that each insertion and removal of the battery will clean the contacts. This is known as “self-cleaning” contacts.

Memory Effect

To maximize the lifetime of your battery, **only charge completely discharged batteries** whenever possible. Charging a partially discharged battery may result in a memory effect in the battery, which reduces the battery capacity, and the number of times it can be effectively charged.

This page is intentionally left blank.

c h a p t e r **4**

**Troubleshooting
PulseStar•610**

This page is intentionally left blank.

Troubleshooting

Introduction

This chapter covers what to do if the PulseStar•610 does not seem to work properly. If you are unable to resolve the problem after using this section, contact Electromotive Systems immediately at 1-800-288-8178.



WARNING

- Only authorized personnel are permitted to perform the initial setup or service work. Use only Electromotive Systems parts.
- Do NOT touch any circuit components on the circuit board while the main AC power is on.
- Do NOT change the address code settings in the receiver.

Common Problems

The following are common problems associated with using the PulseStar•610 system, and their possible solutions. For help in diagnosing problems in the receiver, refer to the drawing in the Start-up and Test Procedures section in chapter 2 that shows the location of each diagnostic LED.

Problem: The transmitter is turned on, but it does not broadcast (Power LED not flashing).

Possible Solution(s):

- Battery is dead. Replace with fully charged battery.
- Fuse located on coder board is blown. Check fuse and replace if blown.
- Key switch is broken. Check wiring to the key switch contact element. Replace key switch wiring or contact element if broken.
- The coder board has failed. Contact Electromotive Systems.

Problem: The transmitter is broadcasting, but all crane motions are not working.

Possible Solution(s):

- The **Active E-STOP** push-button is activated (pushed in). Pull out the **Active E-STOP** push-button and press the **START/HORN** push-button.
- Transmitter is out of range (328 feet typical). Bring the transmitter back into range, and press the **START/HORN** push-button.
- A crane motion function was not 'off' when transmitter was turned on. Make sure all joysticks or paddle levers are in the center (off) position. Cycle transmitter power (turn off and then on) and press the **START/HORN** push-button.
- Incoming power to receiver is off. Turn on power to receiver.
- Fuse is blown in receiver. Check all line fuses and power pack fuses. Replace any blown fuses.

- Receiver is set for different frequency channel. If green Telegram LED located on the decoder board is not flashing, check that the receiver frequency channel matches that of the transmitter.

NOTE: *Always match the transmitter frequency channel to the receiver. Never change the receiver frequency channel without consulting Electromotive Systems first.*

- Receiver is set for different address code. Check to make sure the address code on the decoder board and **Active E-STOP** stop decoder board matches the address code of the transmitter.

NOTE: *Always match the transmitter address code to the receiver. Never change the receiver address code without consulting Electromotive Systems first.*

- **Active E-STOP** failure in transmitter. Check **Active E-STOP** push-button for damage. Check wiring to **Active E-STOP** push-button contact element for broken or disconnected wire(s). Replace broken wire(s) or **Active E-STOP** push-button.
- **Active E-STOP** failure in the receiver. Check red **Active E-STOP** LED on decoder board and **Active E-STOP** decoder board. If it is illuminated:
 - Check to make sure the address code is the same on the decoder board and the **Active E-STOP** decoder board. If they are different consult Electromotive Systems for correct address code and set both the decoder board and **Active E-STOP** decoder board to the correct address code.
 - Wire may have come disconnected from the **Active E-STOP** module, decoder module, or **Active E-STOP** decoder module. Check for loose wiring.
 - **Active E-STOP** module has failed. Replace the **Active E-STOP** module.

Problem: All crane motions work intermittently.

Possible Solution(s):

- Antenna on receiver is loose or has fallen off. Tighten or replace antenna.
- External antenna (when used) is loose, poorly grounded, or receiving interference. See Connecting a Standard External Antenna section in Chapter 2.
- Surge suppressors are not installed on contactors being controlled by the receiver. Make sure all contactors being controlled by the receiver have surge suppressors installed.
- Control wiring may be combined with power wiring. Make sure that all control wiring is separate from power wires.
- Connector inside receiver has come loose. Check all Dubox (blue) connectors.

Problem: Some crane motions work intermittently.

Possible Solution(s):

- Wiring may be loose to that crane motion. Check wiring from the receiver module outputs to the quick disconnect plug, and check wiring from quick disconnect plug to crane motion.
- Connector inside receiver has come loose. Check all Dubox (blue) connectors.
- Surge suppressors may not be installed on contactors controlling that crane motion. Make sure all contactors being controlled by the receiver have surge suppressors installed.
- Control wiring may be combined with power wiring. Make sure that all control wiring is separate from power wires.

Questions to Ask

When reporting a problem to Electromotive Systems you may be asked several questions pertaining to the PulseStar•610 system. Asking these questions to the person who reported the problem prior to calling Electromotive Systems will speed up the troubleshooting process.

General

- Are there other PulseStar systems at or near the crane site?

Transmitter

- Is the **Active E-STOP** push-button pulled out?
- Is the key switch in the ON position?
- Did you press the **START/HORN** push-button?
- Are the joysticks or paddle levers in the center (off) position?
- Did you press the **START/HORN** push-button while accidentally deflecting a joystick or paddle lever?
- Is there a charged battery installed?
- Did you take the transmitter out of its operating range (328 feet)?

Receiver

Open the cabinet enclosure where the receiver is installed, remove the cover, and check the following. Refer to the drawing in the Start-up and Test Procedures section in chapter 2 that shows the location of each diagnostic LED.

- Is the CPU Standby LED flashing?
- Is the Telegram LED flashing?
- Is the **Active E-STOP** LED lit on either the decoder module or **Active E-STOP** decoder module?
- Are the connections/screw terminals tight?
- Is the miniflex antenna securely connected?
- Is the external antenna assembly outside the enclosure securely connected?
- Are all incoming power supply and ground wires properly connected?
- Are the signal wires separated from the power wires?
- Are surge suppressors installed on all magnetic contactors being controlled by the receiver?

a p p e n d i x **A**

Definitions and Abbreviations

This page is intentionally left blank.

Definitions and Abbreviations

Definitions

The following terms are used throughout the *PulseStar•610 Instruction Manual* and may be unfamiliar to some operators.

Term	Definition
analog	Proportional-stepless or infinite control
baud	The transmitting speed measured in bits per second
decoder	Converts a serial data message into parallel signals
double superheterodyne	A method to build an extremely narrow band receiver by converting the receiver frequency twice.
coder	Converts parallel signals into a serial data message
hamming distance	A measurement of data transmission safety. The amount of failures in the data stream which has to occur during the transmission in order to create a wrong signal. A low hamming distance means that the test is not very sensitive to data transmission errors and could be potentially unsafe. A high hamming distance means that the system is very sensitive and could potentially be unreliable due to potential noise interference.
latching	The auxiliary function will turn on when the operator presses option button once and releases it (PBT) or flips the spring return switch up (NVT, GLT, GRT). The auxiliary function will not turn off until the operator presses the option button a second time (PBT) or flips the spring return switch (NVT, GLT, GRT).
maintained	The auxiliary function will turn on when the operator flips the maintained switch to the appropriate position (NVT, GLT, GRT). The auxiliary function will turn off as soon as the operator flips the maintained switch to the off position (NVT, GLT, GRT).
momentary	The auxiliary function will turn on when the operator presses the option button and holds it down (PBT) or flips the spring-return switch and holds it up (NVT, GLT, GRT). The auxiliary function will turn off as soon as the operator releases the option button (PBT) or releases the spring-return switch (NVT, GLT, GRT).
synthesizer technology	Used to electronically generate a carrier frequency.

Commonly Used Abbreviations

Abbreviation	Meaning
A/D	Analog to digital conversion
AK	Analog channel (German: Analog Kanal)
AMP	Ampere
AWG	American wire gauge
BPS	Bits per second
DK	Digital channel (German: Digital Kanal)
EMC	Electromagnetic compatibility
EMI	Electromagnetic immunity
EPROM	Electrical programmable read-only memory
FM	Frequency modulation
GND	Ground
HF	High frequency
KHz	Kilohertz
mAH	Milliamperere hours
mA	Milliamperere
msec	Millisecond
MHz	Megahertz
mW	Milliwatt
NiCd	Nickel cadmium
NiMH	Nickel Metal Hydrite
PLC	Programmable logic controller
PLL	Phased locked loop
PWM	Pulse width modulation
RF	Radio frequency (same as HF - high frequency)
RMS	Root mean squared
Rx	Receiver
RxD	Receiving data
SMD	Surface mount device
SMT	Surface mount technology
TTL	Transistor transistor logic
Tx	Transmitter
TxD	Transmitting data
Ub	Operating power
Uv	Microvolts
VAC	Volts (alternating current)
VDC	Volts (direct current)

a p p e n d i x **B**

Specifications

This page is intentionally left blank.

Specifications

System Specifications

Specification	Setting
Certification	TÜV and CE
Temperature range	-18°F to 158°F (-25°C to 70°C)
Operating range	330 feet (100 meters) typical
Humidity range	0-95% maximum non-condensing
Modulation	Narrow band - FM
Frequency range	400 - 470 MHz (16 preset frequencies)
Bandwidth	12.5 kHz/25kHz
Frequency generation	Microprocessor controlled PLL Synthesizer
Microprocessor	80C31 Intel
Baud rate	4800 bps (approx. 55 msec response time)
Hamming distance	4
Security	16-bit addressing (more than 65,000 possibilities)

NVT Specifications

Specification	NVT
Weight	<2 pounds (including battery)
Physical size (LxWxH)	9.3" x 4" x 6.4" (23.6cm x 10.2cm x 16.3cm)
HF output power	max 10 mW
Deviation	+/- 2kHz
Power supply	9.6 V Nickel Metal Hydrite rechargeable battery
Operation time	7-10 hours with one charge
Enclosure	IP65 Weatherproof (better than NEMA 12/13)
Protection	Key switch with cap
Antenna	Built-in
Functions	Emergency-stop button (push/pull) 4 crane motions Fully-proportional with 8-bit resolution (256 increments for each crane motion activated by joystick and/or lever masters) Horn and mainline activation Toggle switch for auxiliary function (example, micro-positioning) Selector switch (A-A+B-B)
Features	Switch on protection Mechanical protection against accidental activation
Battery charger	115/220 VAC (+/- 20%) Charging time - 4 hours Gold plated and self-cleaning contacts 2 batteries included

GLT Specifications

Specification	GLT
Weight	<4.4 pounds (including battery)
Physical size (LxWxH)	11.7" x 7" x 4.3" (29.7cm x 17.8cm x 10.9cm)
HF output power	approximately 10 mW
Deviation	+/- 2kHz
Power supply	9.6 V Nickel Cadmium rechargeable battery
Operation time	10-12 hours continuous with one charge
Enclosure	IP65 Weatherproof (better than NEMA 12/13) Explosion-proof enclosures available
Protection	Key switch with cap
Antenna	Built-in
Functions	Emergency-stop button (push/pull) 4 crane motions Fully-proportional with 8-bit resolution (256 increments for each crane motion activated by joystick and/or lever masters) Horn and mainline activation Toggle switch for auxiliary function (example, micro-positioning) Selector switch (A-A+B-B)
Features	Switch on protection Mechanical protection against accidental activation
Battery charger	115/220 VAC (+/- 20%) Charging time - 3 hours Gold plated and self-cleaning contacts 2 batteries included

Receiver Specifications

Specification	GA610AS
Operating power	50/110/240 VAC 50/60Hz (+/- 20%)
Current	<100 mA
HF part	Double Superheterodyne
Sensitivity	0.4 microvolts (Root Mean Squared)
Safety	Self-monitoring emergency circuitry Fail-safe, spring-forced Emergency-stop relay Self-test during start-up and operation
Diagnostic	On-board diagnostic system with indicators for: RF communication, power status, active outputs
Output	1 Emergency-Stop relay, 275 VAC 8 Amp/30 VDC 5 Amp 1 Horn relay - normally open, 275 VAC 8 Amp/30 VDC 5 Amp 1 Start/Mainline relay - normally open, 275 VAC 8 Amp/30 VDC 5 Amp 1 Auxiliary relay - normally open, 275 VAC 8 Amp/30 VDC 5 Amp 2 Selector relays - normally open, 275 VAC 8 Amp/30 VDC 5 Amp 4 AD5S analog to 5 step cumulative relay output modules. Each relay is normally open, 275 VAC 8 Amp/30 VDC 5 Amp

Specification	GA610AP
Operating power	50/110/240 VAC 50/60Hz (+/- 20%)
Current	<100 mA
HF part	Double Superheterodyne
Sensitivity	0.4 microvolts (Root Mean Squared)
Safety	Self-monitoring emergency circuitry Fail-safe, spring-forced Emergency-stop relay Self-test during start-up and operation
Diagnostic	On-board diagnostic system with indicators for: RF communication, power status, active outputs
Output	1 Emergency-Stop relay, 275 VAC 8 Amp/30 VDC 5 Amp 1 Horn relay - normally open, 275 VAC 8 Amp/30 VDC 5 Amp 1 Start/Mainline relay - normally open, 275 VAC 8 Amp/30 VDC 5 Amp 1 Auxiliary relay - normally open, 275 VAC 8 Amp/30 VDC 5 Amp 2 Selector relays - normally open, 275 VAC 8 Amp/30 VDC 5 Amp 4 RK-1 analog to directional contact modules. Each relay is normally open, 275 VAC 8 Amp/30 VDC 5 Amp 4 SYM-2 0-10 volts DC output

This page is intentionally left blank.

a p p e n d i x **C**

StarService and Warranty

This page is intentionally left blank.

StarService Policy

This chapter includes information pertaining to on-call service, transmitter loaner and Repair program, and Receiver Replacement/Repair Program warranty. Before you install, troubleshoot, or service the radio control system, we highly recommend that you read this entire chapter. Doing this will help assure quick service response, minimize your on-site repair costs, and reduce crane downtime.

On-Call Service

If you ever have a problem with your PulseStar•609 system, call Electromotive Systems at 1-800-288-8178. Technical support is available 24 hours a day, seven days a week. If necessary, Electromotive Systems can arrange to have a service technician visit your site to evaluate the situation (normally at your expense.)

Warranty

Every PulseStar product includes a two-year warranty from the date of shipment. The warranty is described in detail later in this chapter.

Transmitter Loaner, Replacement & Repair Program

The PulseStar Transmitter Loaner, Replacement & Repair Program provides a replacement transmitter, or loaner transmitter while your transmitter is being repaired. Under the terms of the Loaner, Replacement and Repair Program, please provide a purchase order or credit card to cover the cost of the loaner transmitter.

If you need to return a defective transmitter, please follow the steps below.

1. Request a Return Authorization (RA) from Electromotive Systems' Service Department and return the defective transmitter to Electromotive Systems **via pre-paid freight. When you call, please have the information from the serial nameplate of the transmitter available.**
2. Electromotive Systems will ship a loaner or replacement transmitter within 24 business hours.
3. Electromotive Systems will inspect the defective transmitter and determine if the defects are covered under warranty. If the defects are covered under warranty, Electromotive Systems, at their discretion, will do one of the following:
 - Replace the defective transmitter with the loaner or equivalent transmitter. The replacement transmitter will be covered for the duration of the original transmitter warranty period.
 - Credit the full cost of the loaner transmitter, plus pay for all freight charges for both the loaner transmitter and the transmitter repaired under warranty.

NOTE: Freight charges incurred from sources other than common ground carriers WILL NOT be reimbursed unless pre-approved by Electromotive Systems.

 - If the defects are not covered under warranty, Electromotive Systems will credit the cost of the loaner transmitter, less the cost of the repairs, a \$50 loaner inspection fee, and any freight charges incurred by Electromotive Systems.
4. Electromotive Systems will repair or replace the transmitter. Repaired transmitters will be shipped from Electromotive Systems within 72 business hours of receipt of transmitter (three working days).

5. If the original transmitter is repaired, return the loaner transmitter in good condition to Electromotive Systems **via prepaid freight**.

Receiver Repair Program

The process for returning a defective PulseStar•609 receiver is described in the following steps.

1. Request a Return Authorization (RA) from Electromotive Systems' Service Department and return the defective receiver to Electromotive Systems via prepaid freight. You are responsible for the shipping charges for sending the defective parts to Electromotive Systems.
2. Electromotive Systems will inspect the receiver and determine if the defects are covered under warranty.
 - If the defects are covered under warranty, Electromotive Systems will repair the receiver at no cost, and credit the full cost of all freight charges.

NOTE: Freight charges incurred from sources other than common ground carriers WILL NOT be reimbursed unless pre-approved by Electromotive Systems.

- If the defects are not covered under warranty, you are responsible for the cost of the repairs and all freight charges.

Limited Warranty And Terms Of Sale

Prices: Subject to Change Without Notice
Terms: Net 30 Days

F.O.B. Electromotive Systems, Inc.
Milwaukee, Wisconsin

Electromotive Systems, Inc., hereafter referred to as Company, guarantees all items manufactured by it against any defects of material and/or workmanship for a period of two years from the date of shipment. Company makes **NO OTHER WARRANTY, EXPRESSED OR IMPLIED, AS TO THE MERCHANTABILITY OR FITNESS OF THE ITEMS FOR THEIR INTENDED USE OR AS TO THEIR PERFORMANCE.** Any statement, description or specification in Company's literature is for the sole purpose of identification of items sold by the Company and imparts no guarantee, warranty or undertaking by company of any kind. Components and accessories not manufactured by Electromotive Systems are not included in this warranty and are warranted separately by their respective manufacturers.

Company's sole liability shall be to repair at its factory, or replace any item returned to it within two years from date of shipment, which Company finds to contain defective material or workmanship. All items to be repaired or replaced shall be shipped to Company (Note: return authorization by Company is required) within said two year period, freight prepaid, as a condition to repair or replace defective material or workmanship. Company's herein assumed responsibility does not cover defects resulting from improper installation, maintenance, or improper use. Any corrective maintenance performed by anyone other than the Company during the warranty period shall void the warranty. Company shall not be liable for damages of any kind from any cause whatsoever beyond the price of the defective Company supplied items involved. Company shall not be liable for economic loss, property damage, or other consequential damages or physical injury sustained by the purchaser or by any third party as a result of the use of any Company supplied items or material.

Company neither assumes nor authorizes any other person to assume for Company any other liability in connection with the sale or use of items sold by Company.

List prices or discounts are subject to change without notice. Quoted prices will be honored for a period of 30 days from the date of the written quotation unless otherwise stated.

Orders of \$25,000 or more, and orders for special control panels are subject to special terms and conditions of sale. Refer to those specific sections within this document.

Orders are not subject to alteration or cancellation except upon written consent of Company and payment of proper cancellation charges, when deemed applicable by Company.

Materials or items may not be returned for credit, without the prior written consent of the Company. Any authorized return of materials or items shall be subject to a restocking charge equal to 20% of the net invoiced amount after Company determines that the material or item is in good condition and may be resold without alteration or service. If upon receipt of the material or items returned, the Company determines that said materials or items cannot be resold without alteration or service, the Company reserves the right to reject the returned materials or items and to send the same back to said purchaser at purchaser's expense.

Terms of payment are NET 30 days. All materials and items are sold F.O.B. Company's shipping point. Company retains a security interest in all items sold by it so long as they remain in Company's possession to secure all obligations of purchaser to Company. A processing fee will be applied to all invoices for requested prepaid freight charges other than UPS. A service charge will be incurred on past due accounts extending beyond the Terms of Sale described above, at a rate of 1.5 per month or a fraction thereof, of the net balance extending beyond 30 days..

Any claim for errors in shipment or for material or item shortages must be received by Company within 30 days of shipment and must be accompanied by copies of the bill of lading and packing slip.

Special Terms and Conditions: Orders of \$25,000 or More

Electrification and Control Orders

Drawings and Drawing Approvals (if applicable)

In most cases, Electromotive Systems will submit drawings for customer approval within 30 days after receipt of purchase order.

Customer drawing approval and Electromotive Systems credit approval is required before Electromotive Systems will proceed with parts procurement or assembly work.

Progress payment

25% of total order is required prior to shipment.

75% balance to be paid Net 30 days upon shipment of order.

Customer Requested Changes

Customer shall pay for any additional charges that may be incurred due to customer change orders as incurred.

Cancellation Policy

Cancellation fee of 10% of orders, plus all charges that may be incurred to-date of cancellation, will be applicable to all orders cancelled after receipt of order.

Credit Approval

All orders are subject credit approval by Electromotive Systems, Inc.

All items manufactured and offered for sale by Electromotive Systems, Inc. are subject to limited warranty and terms of sale. These special terms and conditions are part of the limited warranty and terms, and only supersede to take exception to said warranty and terms section of this document for a complete description.

Special Terms and Conditions: Orders for Special Control Panels

Drawing and Drawing Approvals

In most cases, Electromotive Systems will submit drawings for customer approval within 30 days after receipt of purchase order.

Customer drawing approval and Electromotive Systems credit approval is required before Electromotive Systems will proceed with parts procurement or assembly work.

Progress payments

25% of total net order is required upon drawing approval.

25% of total net order is required prior to shipment.

50% balance to be paid Net 30 days upon shipment of order.

Customer Requested Changes

Customer shall pay for any additional charges that may be incurred due to customer change orders as incurred.

Cancellation Policy

Cancellation fee of 10% of order, plus all changes that may be incurred to-date of cancellation, will be applicable to all orders cancelled after receipt of purchase order.

Credit Approval

All orders are subject to credit approval by Electromotive Systems, Inc.

All items manufactured and offered for sale by Electromotive Systems, Inc. are subject to limited warranty and terms of sale. These special terms and conditions are part of the limited warranty and terms, and only supersede to take exception to said warranty and terms as specifically outlined. Refer to limited warranty and terms section of this document for a complete description.

This page is intentionally left blank.