



# Yale® YK/Shaw-Box® SK Crane Kit Intelli-Protect® Technical Manual



Part Number: 192088724 Rev AC  
April 2023  
© Copyright 2023 Magnetek

**Page Intentionally Left Blank**

# SERVICE INFORMATION

For questions regarding service or technical information contact:

1.866.MAG.SERV  
(1.866.624.7378)

## International Service

Outside the U.S. and Canada call +1.262.783.3500, press 3.

## Columbus McKinnon Corporation Locations

### Magnetek

N49 W13650 Campbell Drive  
Menomonee Falls, WI 53051

**Telephone:** 800.288.8178  
**E-mail:** field.service@magnetek.com

### Fax Numbers:

**Main:** 800.298.3503  
**Sales:** 262.783.3510  
**Service:** 262.783.3508

### Canada

161 Orenda Road  
Unit 1  
Brampton, Ontario  
L6W 1W3 Canada

**Telephone:** 800.792.7253  
**Fax:** 905.828.5707  
416.424.7617 (24/7 Service pager)

### Europe

STAHL CraneSystems GmbH  
**Telephone:** +49 7940 128-0  
**E-mail:** mh.eurosales@magnetek.com

### Website

<https://www.columbusmckinnon.com/magnetek>

### © 2023 Columbus McKinnon Corporation

All rights reserved. This notice applies to all copyrighted materials included with this product, including, but not limited to, this manual and software embodied within the product. This manual is intended for the sole use of the person(s) to whom it was provided, and any unauthorized distribution of the manual or dispersal of its contents is strictly forbidden. This manual may not be reproduced in whole or in part by any means whatsoever without the expressed written permission of the Columbus McKinnon Corporation.

# PREFACE AND SAFETY

## Product Safety Information

Magnetek offers a broad range of radio remote control products, control products and adjustable frequency drives, industrial braking systems, and power delivery products for material handling applications. This manual has been prepared by Magnetek to provide information and recommendations for the installation, use, operation and service of Magnetek's material handling products and systems (Magnetek Products). Anyone who uses, operates, maintains, services, installs or owns Magnetek products should know, understand and follow the instructions and safety recommendations in this manual for Magnetek products.

The recommendations in this manual do not take precedence over any of the following requirements relating to cranes, hoists, lifting devices or other equipment which uses or includes Magnetek products:

- Instructions, manuals, and safety warnings of the manufacturers of the equipment where the Magnetek Products are used,
- Plant safety rules and procedures of the employers and the owners of the facilities where the Magnetek Products are being used,
- Regulations issued by the Occupational Health and Safety Administration (OSHA),
- Applicable local, state, provincial, or federal codes, ordinances, standards and requirements, or
- Safety standards and practices for the industries in which Magnetek Products are used.

This manual does not include or address the specific instructions and safety warnings of these manufacturers or any of the other requirements listed above. It is the responsibility of the owners, users and operators of the Magnetek Products to know, understand and follow all these requirements. It is the responsibility of the employer to make its employees aware of all the above listed requirements and to make certain that all operators are properly trained. **No one should use Magnetek Products prior to becoming familiar with and being trained in these requirements and the instructions and safety recommendations for this manual.**

## Product Warranty Information

For information on Magnetek's product warranties by product type, please visit the Material Handling site at [www.columbusmckinnon.com/magnetek](http://www.columbusmckinnon.com/magnetek).

## DANGER, WARNING, CAUTION and NOTE Statements

Read and understand this manual before installing, operating, or servicing this product.

The following conventions indicate safety messages in this manual. Failure to heed these messages could cause fatal injury or damage products and related equipment and systems.

### DANGERS, WARNINGS and CAUTIONS

Throughout this document DANGER, WARNING and CAUTION statements have been deliberately placed to highlight items critical to the protection of personnel and equipment.



DANGER indicates an imminently hazardous situation which, if not avoided, will result in death or serious injury. This signal word is to be limited to the most extreme situations.



WARNING indicates a potentially hazardous situation which, if not avoided, could result in death or serious injury.



CAUTION indicates a potentially hazardous situation which, if not avoided, could result in minor or moderate injury. It may also be used to alert against unsafe practices.



- Read this user manual in its entirety before installing Intelli-Protect software.
- DO NOT connect or disconnect wiring or perform signal checks while the electrical power is ON.
- Improper programming with this software can lead to unexpected, undesirable, or unsafe operation.

Failure to observe these and other precautions indicated in this manual will expose the user to high voltages, resulting in serious injury or death. Damage to equipment may also occur.



## CAUTION

No patent liability is assumed with respect to the use of the information contained herein. Moreover, Magnetek is constantly improving its high-quality product; therefore, the information contained in this manual is subject to change without notice. Every precaution has been taken in the preparation of this document. Nevertheless, Magnetek assumes no responsibility for errors or omissions. Neither is any liability assumed for damages resulting from the use of the information contained in this publication.

**NOTE:** A *NOTE* statement is used to notify people of installation, operation, programming or maintenance information that is important, but not hazard-related.

# Table of Contents

1	Introduction .....	8
1.1	Intelli-Protect® Model Numbers .....	8
1.1.1	Intelli-Protect® Configurable No-Fly Zones .....	9
1.2	Intelli-Protect® Parts .....	10
1.3	Flexible Configurations with User Interface (UI) .....	10
1.4	Light Stack .....	11
2	Mechanical Installation .....	12
2.1	Environmental Ratings and Certifications .....	13
2.2	Laser Specification .....	13
2.3	Reflector Installation .....	15
2.3.1	Trolley Reflector .....	16
2.3.2	Bridge Reflector .....	18
2.4	50 m Laser Installation and Wiring .....	19
2.4.1	Trolley Motion 50 m .....	20
2.4.2	Bridge Motion 50 m .....	21
2.4.3	50 m Laser Wiring .....	23
2.5	150 m and 300 m Laser Installation and Wiring .....	24
2.5.1	Bridge Motion 150 m / 300 m Laser .....	25
2.5.2	150 m and 300 m Laser Wiring .....	27
2.6	Laser Alignment Instructions .....	28
2.7	Light Stack Installation .....	29
3	Power and Control Wiring .....	31
3.1	Control Inputs .....	31
3.2	Intelli-Protect Control Outputs .....	34
3.2.1	Control Outputs .....	35
4	Configurable No-Fly Zone Setup .....	36
4.1	Connecting to Web Server .....	36
4.2	Configurable Initial Setup .....	37
4.3	How to Configure Travel Limits .....	38
4.3.1	Trolley Configuration Steps .....	39
4.3.2	Bridge Configuration Steps .....	42
4.4	Zone Setup .....	45
4.4.1	Load Size Consideration .....	46
4.5	Enabling Zones .....	47
4.6	Hoist Upper Limit and Machine Down Configuration .....	48
4.7	Slowdown Only Configuration .....	49
4.8	Zone Overview .....	50
5	Intelli-Protect® Inputs and Outputs .....	52
6	Troubleshooting .....	54
6.1	Light Stack Indicators and Corrective Actions .....	54
6.2	Alarms and Corrective Actions During Operation .....	55
7	Other Features .....	56
7.1	Horn/Zone Override .....	56
7.2	Machine Lowered Example .....	57
7.3	Slowdown Only Configuration .....	58
7.4	Additional Slowdown and Stop Distances .....	59
7.5	End of Travel Zones .....	59
8	Appendix .....	61
8.1	Wireless SSID Setup and Password .....	61

# 1 Introduction

Protect personnel and valuable assets with Intelli-Protect No-Fly Zone systems. No-Fly Zones (NFZs) refer to protected areas where normal crane operation is limited or entirely restricted. Magnetek-brand Intelli-Protect Systems, part of the Intelli-Crane™ portfolio of products, allow you to designate locations where a crane is programmed to slow down or stop, using motion control products such as variable-frequency drives, radio remote controls, and sensors.

These versatile systems – ranging from simple to complex configurations – can be added to existing crane controls or introduced as new installations for a variety of industries, including automotive, steel, manufacturing, and pulp and paper.

## 1.1 Intelli-Protect® Model Numbers

<b>Monorail Hoist</b>		
<b>Intelli-Protect Configurable Location Description</b>	<b>Hoist Frames A, B, C</b>	<b>Hoist Frames D, E</b>
Configurable Intelli-Protect (50 x 50 m)	NFZ-CONFIG-5050 M1	NFZ-CONFIG-5050 M2
Configurable Intelli-Protect (50 x 300 m)	NFZ-CONFIG-50300 M1	NFZ-CONFIG-50300 M2
<b>Top Running Hoist</b>		
<b>Intelli-Protect Configurable</b>	<b>Hoist Frames A, B, C, D</b>	<b>Hoist Frames E</b>
Configurable Intelli-Protect (50 x 50 m)	NFZ-CONFIG-5050 TR1	NFZ-CONFIG-5050 TR2
Configurable Intelli-Protect (50 x 150 m)	NFZ-CONFIG-50150 TR1	NFZ-CONFIG-50150 TR2
Configurable Intelli-Protect (50 x 300 m)	NFZ-CONFIG-50300 TR1	NFZ-CONFIG-50300 TR2



### 1.1.1 Intelli-Protect® Configurable No-Fly Zones

Configurable No-Fly Zone systems utilize laser positioning sensors installed on bridge/trolley motions that interface with a No-Fly Zone controller. This system incorporates a simplified menu-driven operator interface accessed over a wireless connection via the use of a Personal Electronic Device (PED) such as a laptop, smartphone, or tablet.

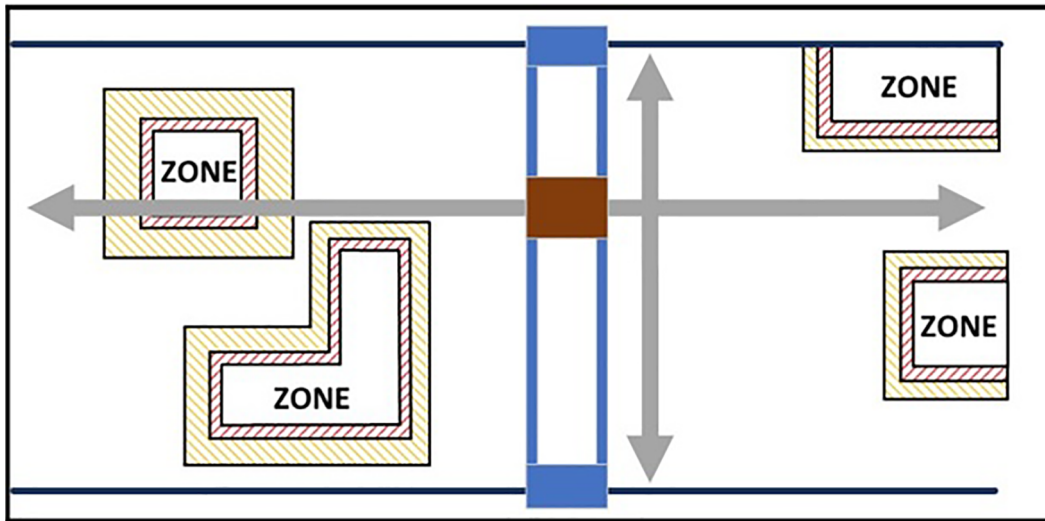

**Figure 1-1: Configurable NFZ Example Configurations (Overhead Traveling Bridge Crane)**

- Enable and configure up to 31 No-Fly Zones
- Quickly define NFZ boundaries using two diagonal corner positions while positioning hoist or enter location manually
- Determine position using lasers for 50,150, and 300 meter spans and runways
- Define bridge and trolley slow, stop, and protected boundaries using laser positioning
- Using a PED (smartphone, tablet), open a **Zone Overview** screen:
  - See NFZ boundaries on runway floor plan
  - See updated position of the crane as it moves
  - See active zone states (red - within restricted zone, yellow - within stop zone, blinking yellow - within slowdown zone, green - outside of zone)
- Light stack with horn for visual and audible notifications
- Hoist upper travel limit switch provides the option to fly over selected zones when enabled
- One external key switch to disable protection zones
- One external key switch to disable Wi-Fi

## 1.2 Intelli-Protect® Parts

NFZ-CONFIG-5050		
Intelli-Protect	Spec	Qty
Intelli-Protect® Control Panel	Includes PLC, Wi-Fi, quick connect plug	1
Light Stack with Horn	Field mounted, includes cable	1
Bridge Motion Laser	50 m laser, cables, and mounting bracketry	1
Bridge Reflector	Field mounted, reflector 24 x 24 in., DIN rail mounting	1
Trolley Motion Laser	50 m laser, cables, and girder mounting bracketry	1
Trolley Motion Reflector	Reflector 24 x 24 in., hoist mounting bracketry	1

NFZ-CONFIG-50300		
Intelli-Protect	Spec	Qty
Intelli-Protect Control Panel	Includes PLC, Wi-Fi, quick connect plug	1
Light Stack with Horn	Field mounted, includes cable	1
Bridge Motion Laser	150 m laser, cables, and mounting bracketry	1
Bridge Reflector	Field mounted, reflector 24 x 24 in., DIN rail mounting	6
Trolley Motion Laser	50 m laser, cables, and girder mounting bracketry	1
Trolley Motion Reflector	Reflector 24 x 24 in., hoist mounting bracketry	1

## 1.3 Flexible Configurations with User Interface (UI)

Through our web-based UI, a user can perform the following standard operations using an iPhone, iPad, Android mobile or host computer over Wi-Fi:

- Configure your factory's Bridge and Trolley span limits
- View **Alarm List** showing active encroachments of user-defined slowdown and stop boundaries
- Configure End-of-Travel Zones
- Configure hoist upper travel limit or machine lowered signal to provide the option to fly over selected zones
- Configure a zone to be slowdown only

## 1.4 Light Stack

Three-Segment light stack with horn

Light Indicators		Intelli-Protect®
Color	Industry Standard	No-Fly Zone
Green	Safe/Normal	Power on, PLC running - Solid
Amber	Warning/Abnormal	Within Stop Zone - Solid Within Slowdown Zone - Flashing
Red	Danger/Fault	Within Restricted Zone - Solid
		Bypass - Flashing with horn sound No Zones Configured – Flashing with no horn

**NOTE:** If the panel bypass key switch is switched to disable the No-Fly Zone protection, the red light will flash continuously until protection has been re-enabled by the bypass key switch. When Bypass is initiated the Horn will turn on for 10 seconds and off for 10 seconds (this will happen twice). When the Normal Operation is initiated the Horn will sound for 2 seconds then shut off.

## 2 Mechanical Installation

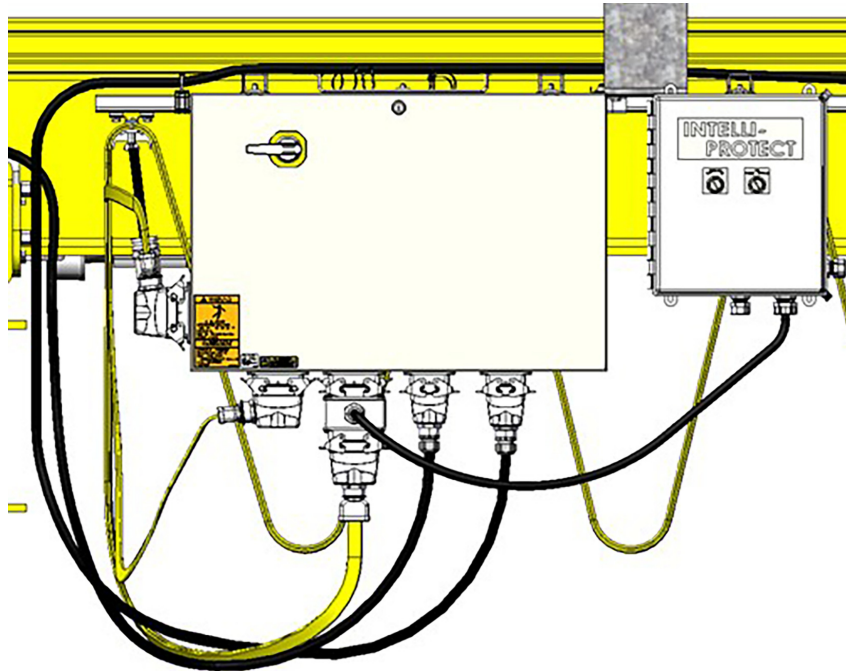

**Figure 2-1: Intelli-Protect Control Panel Mounting**

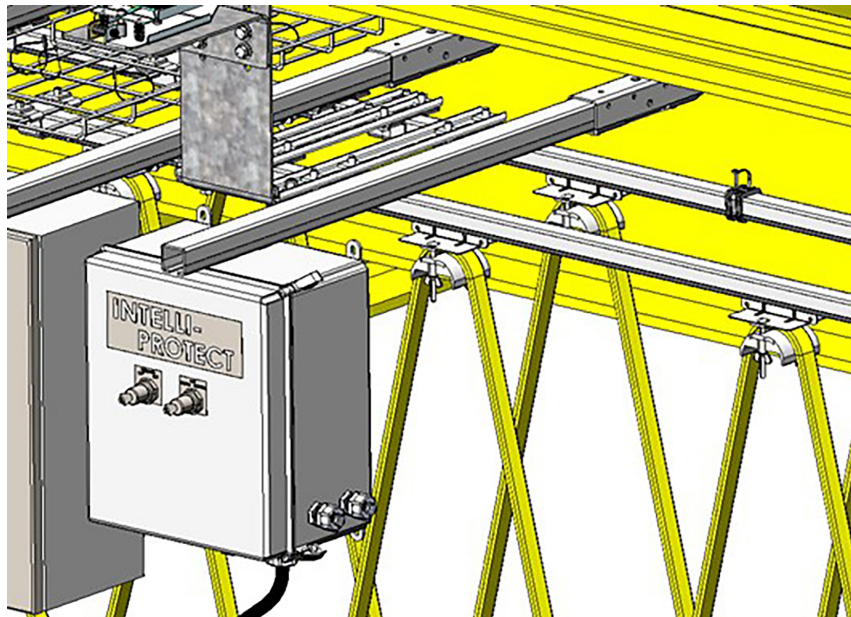

**Figure 2-2: Cross Arm Support Mounting**

- External panel-mounted key switch to disable protection zones and allow movement into all zones
- Padlock provision is included
- External mounted key switch to disable Wi-Fi connection after configuration

## 2.1 Environmental Ratings and Certifications

Specification	Panel
Operating Temperature	14°F to 122°F (-10°C to 50°C) max.
Vibration	3.5 mm / 3 gn at 8.4 to 150 Hz
Humidity	95% without condensation
Environmental Classification	NEMA 4X / IP 65
Certification	UL508A Industrial Control Panel

Suitable for outdoor use. For direct sunlight or extreme temperatures, contact Columbus McKinnon.

## 2.2 Laser Specification

### Intelli-Protect 50 x 50 m Laser Specifications

Specification	Laser
Operating Temperature	-22°F to 131°F (-30°C to 55°C)
Operating Range	8 in. to 150 ft
Accuracy	1 in.
Laser Class	1
Wavelength	660 Nm
Ambient Light Limit	50000 Lux
Weight	0.2 lb

### Intelli-Protect 150 and 300 m Laser Specifications

Specification	Laser
Ambient Temperature	14°F to 122°F (-10°C to 50°C)
Operating Range	0.3 to 150 m/300 m
Resolution	0.1 mm, adjustable
Laser Class	Measurement laser: 1 Alignment laser: 2
Wavelength	Measurement laser: 905 Nm Alignment laser: 660 Nm
Ambient Light Limit	>100000 Lux
Weight	1.5 lb

## Beam Diameter at Each Distance

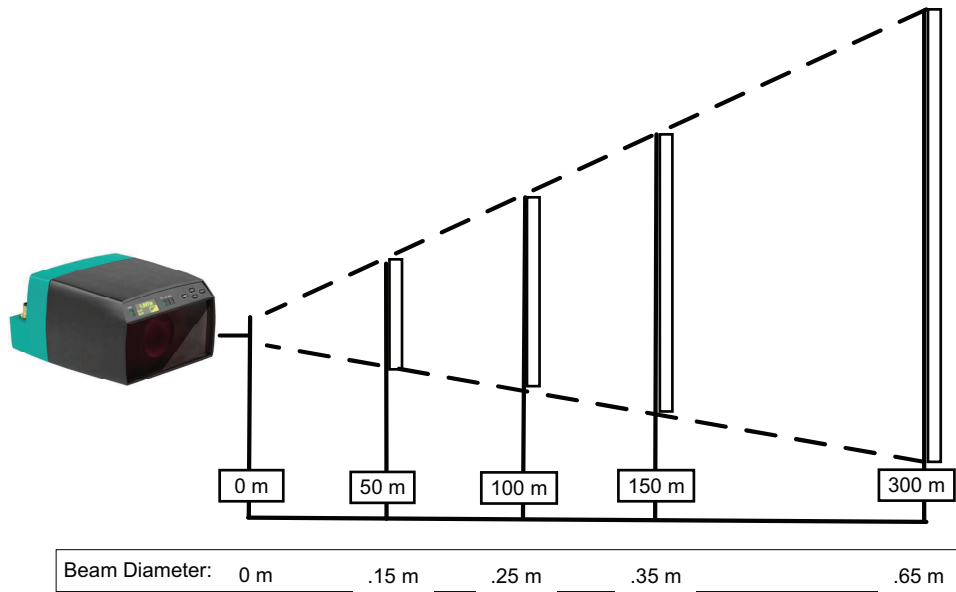

**Figure 2-3: Beam Diameter at Each Distance (Side View of Laser)**

## 2.3 Reflector Installation

For best reflectivity/laser signal, mount the reflector in the same orientation as the laser so the laser beam is perpendicular to the reflector. The arrow on the back of the reflector should be the same direction as the laser. **See Figure 2-4** below.

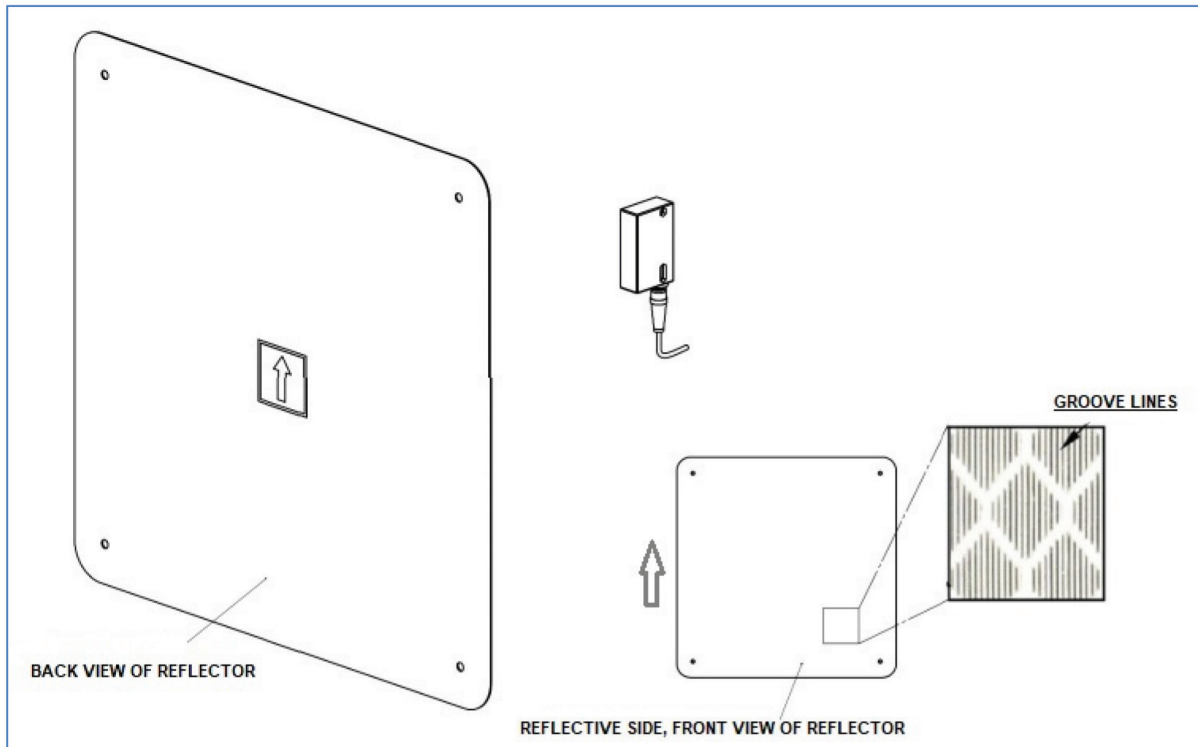

**Figure 2-4: Mounting the Laser**

Reflector	Mounting Guide Reflector Layout	Qty
<b>NFZ-CONFIG-5050</b>		
Trolley Reflector	1 wide x 1 high	1
Bridge Reflector	1 wide x 1 high	1
<b>NFZ-CONFIG-50300</b>		
Trolley Reflector	1 wide x 1 high	1
Bridge Reflector	3 wide x 2 high	6

## 2.3.1 Trolley Reflector

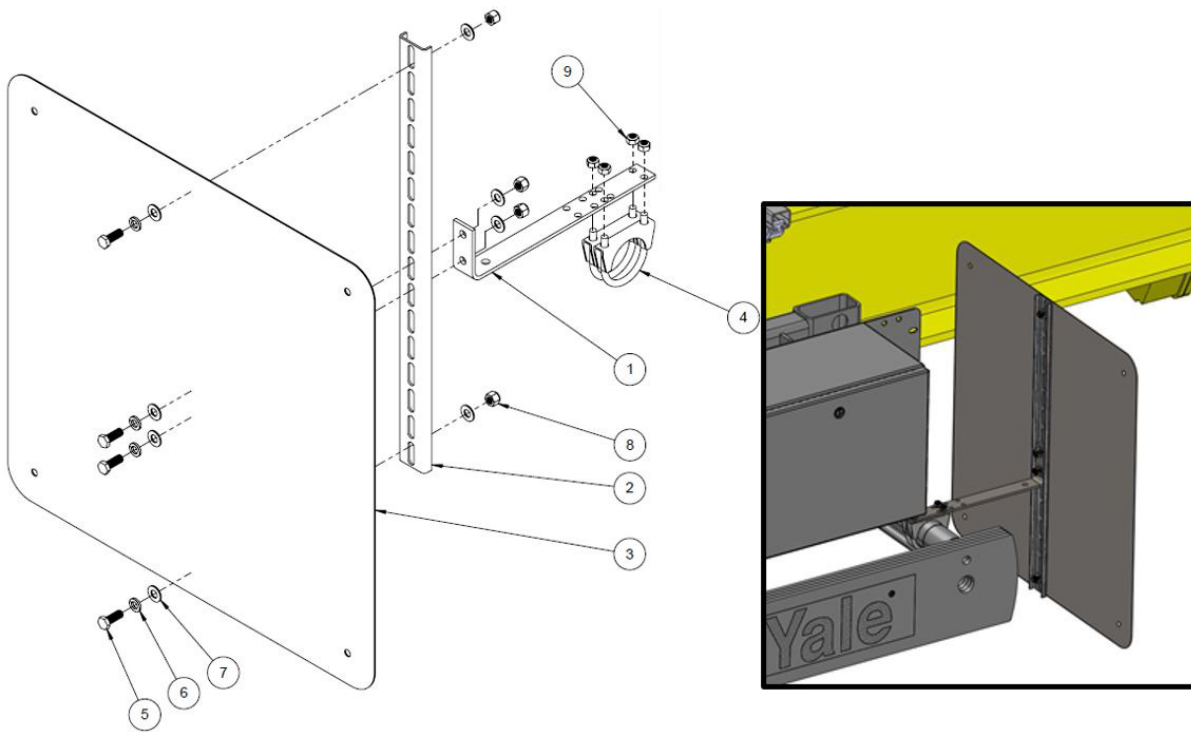

Item No.	Description	Qty
1	Bracket, Reflector, Monorail, Trolley Motion	1
2	BKS-F24-G Flange Mount BR	1
3	Reflector DIN-Mount, 24 x 24	1
4	Clamp, U-Bolt, M8, Dia. 48 mm, Frame A Clamp, U-Bolt, M8, Dia. 58 mm, Frame B Clamp, U-Bolt, M8, Dia. 75 mm, Frame C	2
5	Hex Cap Screw, Shallow Head, 3/8-16 x 1	4
6	Lock Washer, 3/8	4
7	Washer, 3/8 SAE	8
8	Nut, Nylon, 3/8	4
9	Nut, Nylon, M8	4

**Figure 2-5: Monorail Version**



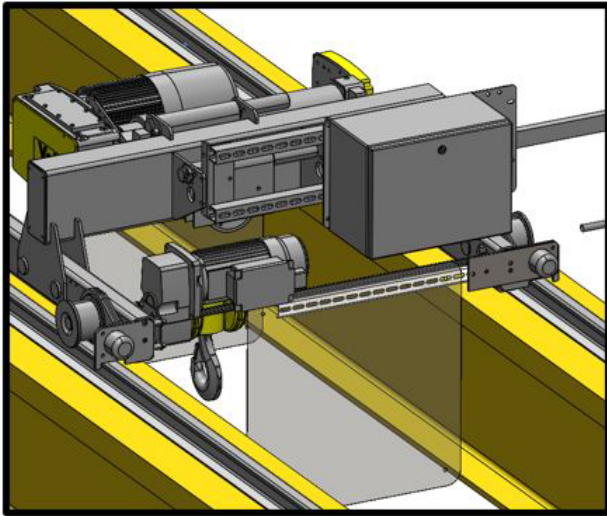

Frames A and B

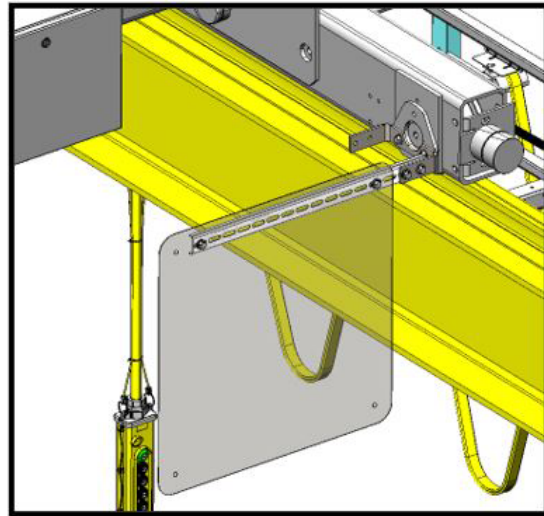

Frames C and D

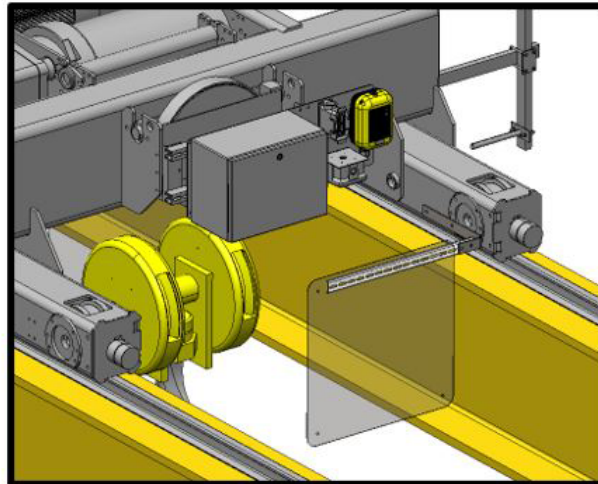

Frame E

**Figure 2-6: Top Running Version**

## 2.3.2 Bridge Reflector

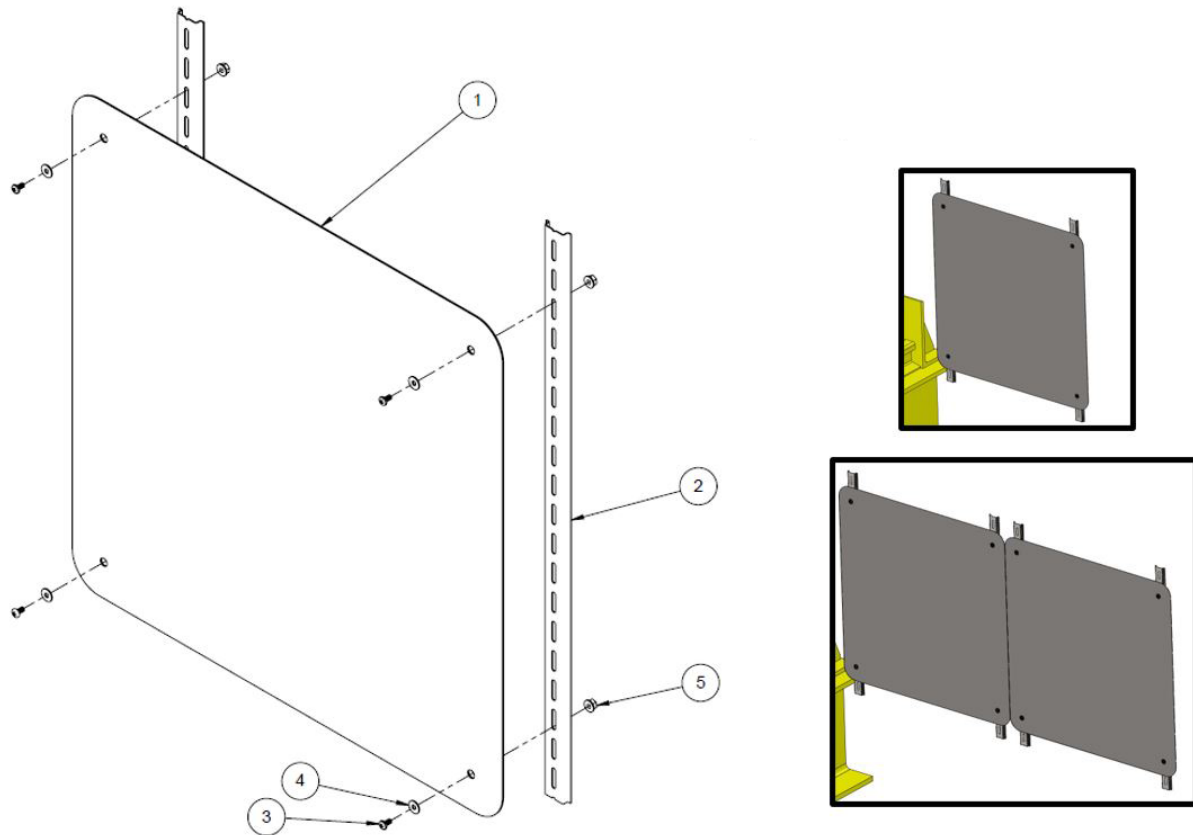

Item No.	Description	Qty
1	Reflector DIN-Mount, 24 x 24	1
2	DIN Rail, LaserGuard Reflector	2
3	PHMS, #10-32 x 3/8	4
4	Washer, .25 ID x .562 OD	4
5	Nut, #10-32, ESNA, Zinc	4

**Figure 2-7: DIN Rail Mounting Arrangement**

## 2.4 50 m Laser Installation and Wiring



Intelli-Protect 50 m Configurable systems contain Class 1 lasers with a 660 Nm wavelength. Although the laser is eye-safe, it is recommended that no one look directly into the laser with their eye close to the lens of the laser unit. Do not open the laser unit to service it since there are no serviceable parts inside.

The Intelli-Protect 50 m System measures the distance between the trolley or bridge mounted laser lens and the target reflector. There must be no projections on the crane that may extend in front of either (or both) the laser unit or the reflector.

Make sure the laser is mounted such that nothing can come between the laser's view of the reflector.

Determine the mounting position for the laser and the target such that the center of the laser's faceplate and the center of the reflector are the same distance above the plane the crane rails are in. The laser and reflector center point should also be the same distance from the rails. This is the most important part of a successful installation since the laser beam must stay on the reflector at all range points anywhere in the bay.

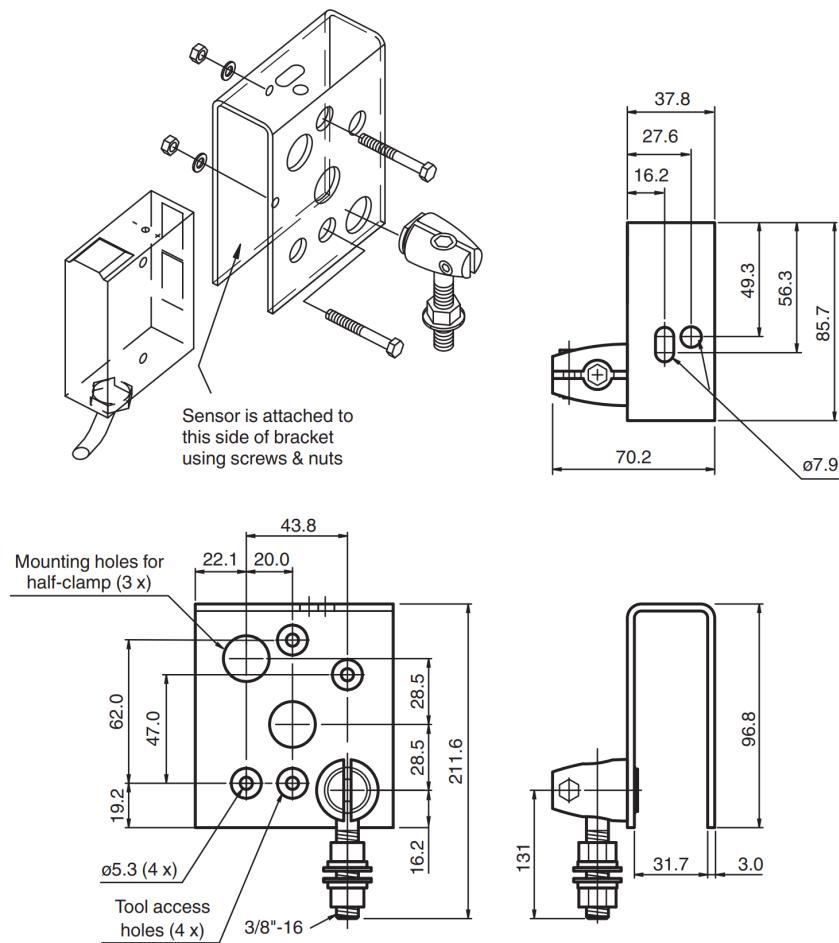

**Figure 2-8: Installing the Laser**

## 2.4.1 Trolley Motion 50 m

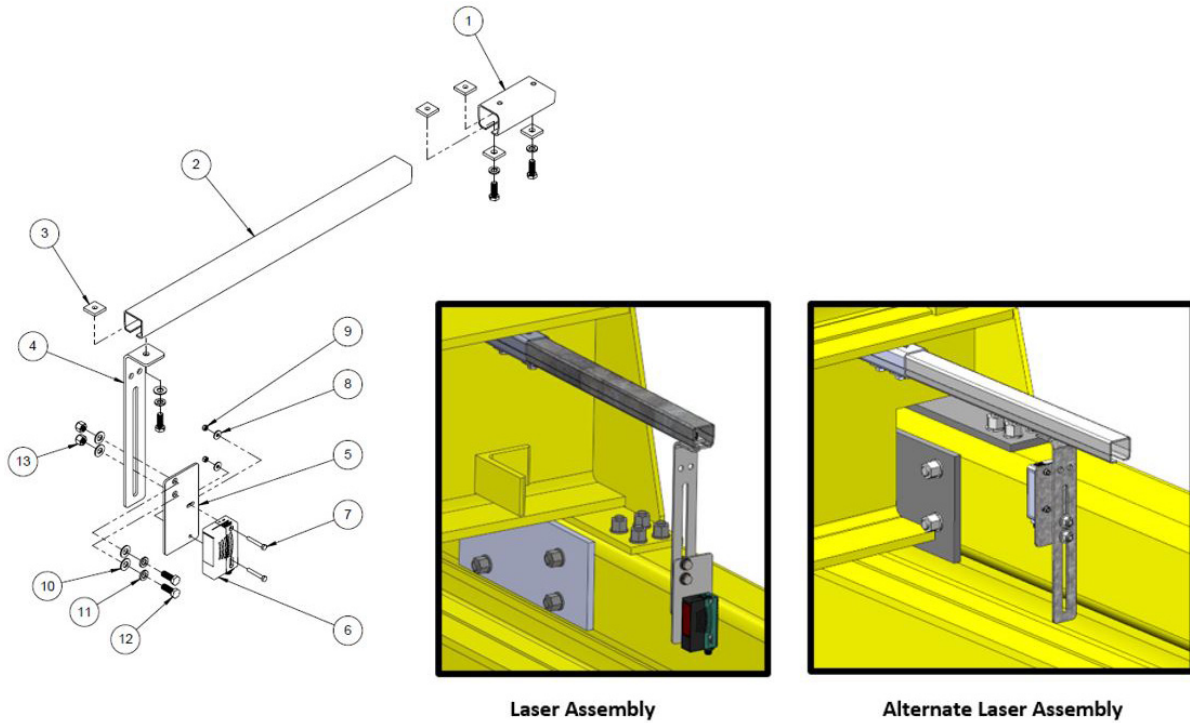

Item No.	Description	Qty
1	Weld Cross Arm Socket	1
2	F-12CT10 C-Track 12GA	1
3	F-A005C Square Nut Tapped	1
4	Bracket, Slotted, 50 m Sensor, Reflector Trolley and Bridge Motion	1
5	Bracket, Flat, 50 m Sensor Mount, Trolley and Bridge Motion	1
6	50 m Sensor	1
7	Hex-Head Cap Screw, M5 x 35, Steel, Zinc-Plated	2
8	Flat Washer, M5	2
9	Nut, Nylon, M5	2
10	Washer, 3/8 SAE	5
11	Lock Washer, 3/8	3
12	Hex Cap Screw, Shallow Head, 3/8-16 x 1	3
13	Nut, Nylon, 3/8	2

**Figure 2-9: Girder Mounting (Weld Mount to Bridge)**

## 2.4.2 Bridge Motion 50 m

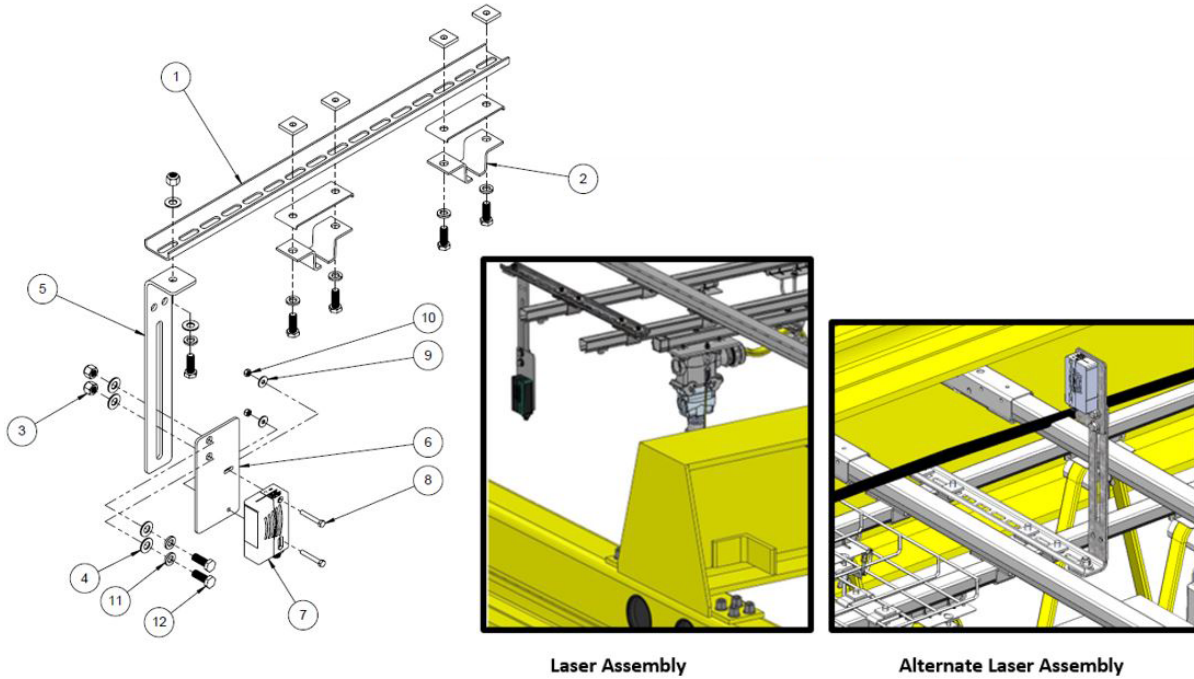

Item No.	Description	Qty
1	BKS-F24-G Flange Mount BR	1
2	F-CTH Low-Profile Hanger	2
3	Nut, Nylon, 3/8	3
4	Washer, 3/8 SAE	6
5	Bracket, Slotted, 50 m Sensor, Reflector Trolley and Bridge Motion	1
6	Bracket, Flat, 50 m Sensor Mount, Trolley and Bridge Motion	1
7	50 m Sensor	1
8	Hex-Head Cap Screw, M5 x 35, Steel, Zinc-Plated	2
9	Flat Washer, M5	2
10	Nut, Nylon, M5	2
11	Lock Washer, 3/8	3
12	Hex Cap Screw, Shallow Head, 3/8-16 x 1	3

**Figure 2-10: Festoon Side Mounting**

## Weld Mount to Bridge Solution

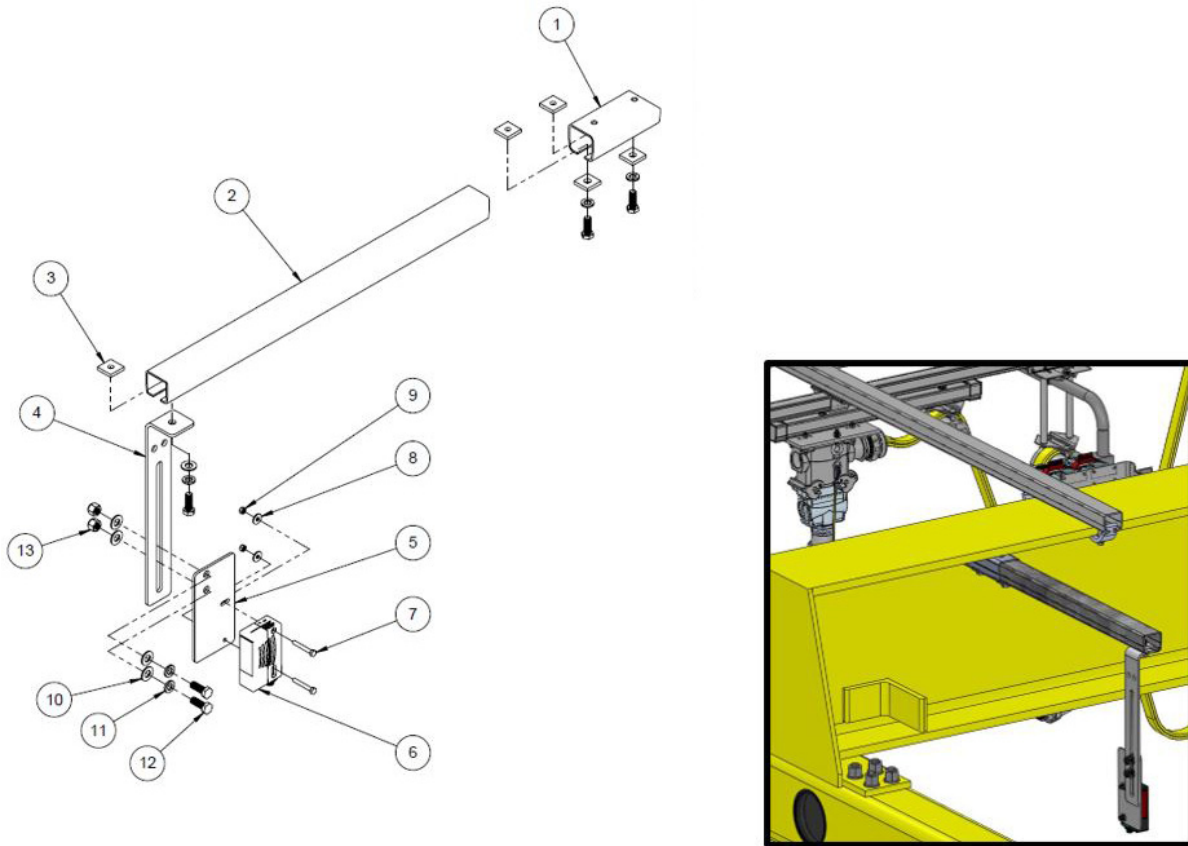

Item No.	Description	Qty
1	Weld Cross Arm Socket	1
2	F-12CT10 C-Track 12GA	1
3	F-A005C Square Nut Tapped	1
4	Bracket, Slotted, 50 m Sensor, Reflector Trolley and Bridge Motion	1
5	Bracket, Flat, 50 m Sensor Mount, Trolley and Bridge Motion	1
6	50 m Sensor	1
7	Hex-Head Cap Screw, M5 x 35, Steel, Zinc-Plated	2
8	Flat Washer, M5	2
9	Nut, Nylon, M5	2
10	Washer, 3/8 SAE	5
11	Lock Washer, 3/8	3
12	Hex Cap Screw, Shallow Head, 3/8-16 x 1	3
13	Nut, Nylon, 3/8	2

**Figure 2-11: Non-festoon Side Mounting**

### 2.4.3 50 m Laser Wiring

## 50m LASER OPTIONS

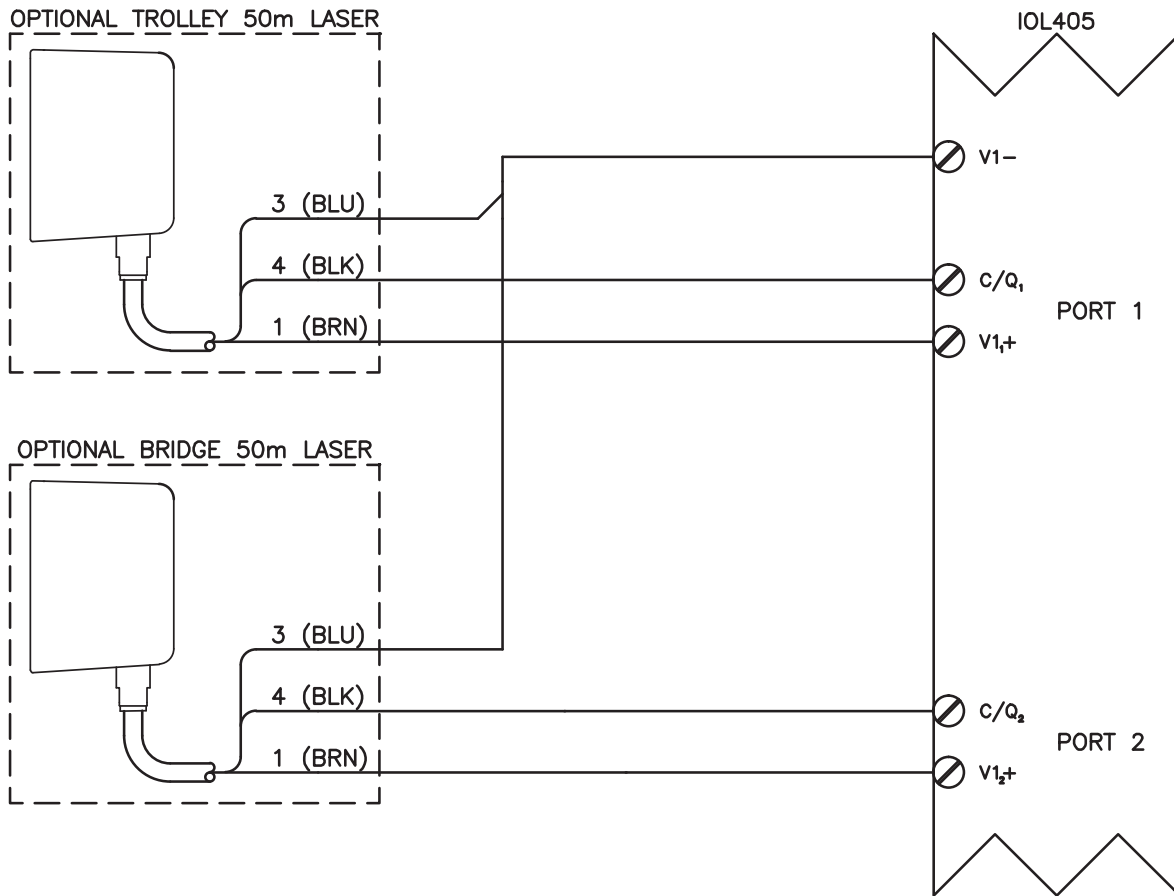

**Figure 2-12: 50 m Laser Options**

## 2.5 150 m and 300 m Laser Installation and Wiring



### CAUTION

Intelli-Protect 150 and 300 m Configurable systems contain Class 1 measurement and Class 2 alignment lasers with visible and invisible laser radiation. Do not look at the beam. The irradiation can lead to irritation especially in a dark environment. Do not open the laser unit to service it since there are no serviceable parts inside.

The Intelli-Protect 150 m and 300 m Systems measure the distance between the trolley or bridge mounted laser lens and the target reflector. There must be no projections on the crane that may extend in front of either (or both) the laser unit or the reflector.

Make sure the laser is mounted such that nothing can come between the laser's view of the reflector.

Determine the mounting position for the laser and the target such that the center of the laser's faceplate and the center of the reflector are the same distance above the plane the crane rails are in. The laser and reflector center point should also be the same distance from the rails. This is the most important part of a successful installation since the laser beam must stay on the reflector at all range points anywhere in the bay.

**NOTE:** Alignment (pointer) laser will blink at approximately 1 Hz when target signal is lost, and will flash for an additional 2 minutes before deactivating automatically.

When mounting reflectors, keep the alignment beam (laser pointer) completely on target, and do not allow a beam to partially fall off a reflector's edge. The alignment laser should be enabled during setup.

The table below may be used to identify how far off center a beam may stray before a partial loss of signal will occur.

**Example:** At 150 m, the infrared measurement beam diameter is 35 cm. The total reflector width of the recommended 2-wide setup is 122 cm (61 cm reflector). There will be 43.5 cm on each side of the measurement beam on a perfectly centered system. This is the off-center horizontal tolerance value.

**Example Horizontal off-center tolerance:**  $(122 \text{ cm} - 35 \text{ cm}) / 2 = 43.5 \text{ cm}$

Laser	Beam Diameter	Beam Tolerances Off Center		Reflector Width	Reflector Height
		Horizontal	Vertical		
@ 150 m	35 cm	+/- 43.5 cm	+/- 13 cm	122 cm (2 wide)	61 cm (1 high)
@ 300 m	65 cm	+/- 59 cm	+/- 28.5 cm	183 cm (3 wide)	122 cm (2 high)



## 2.5.1 Bridge Motion 150 m / 300 m Laser

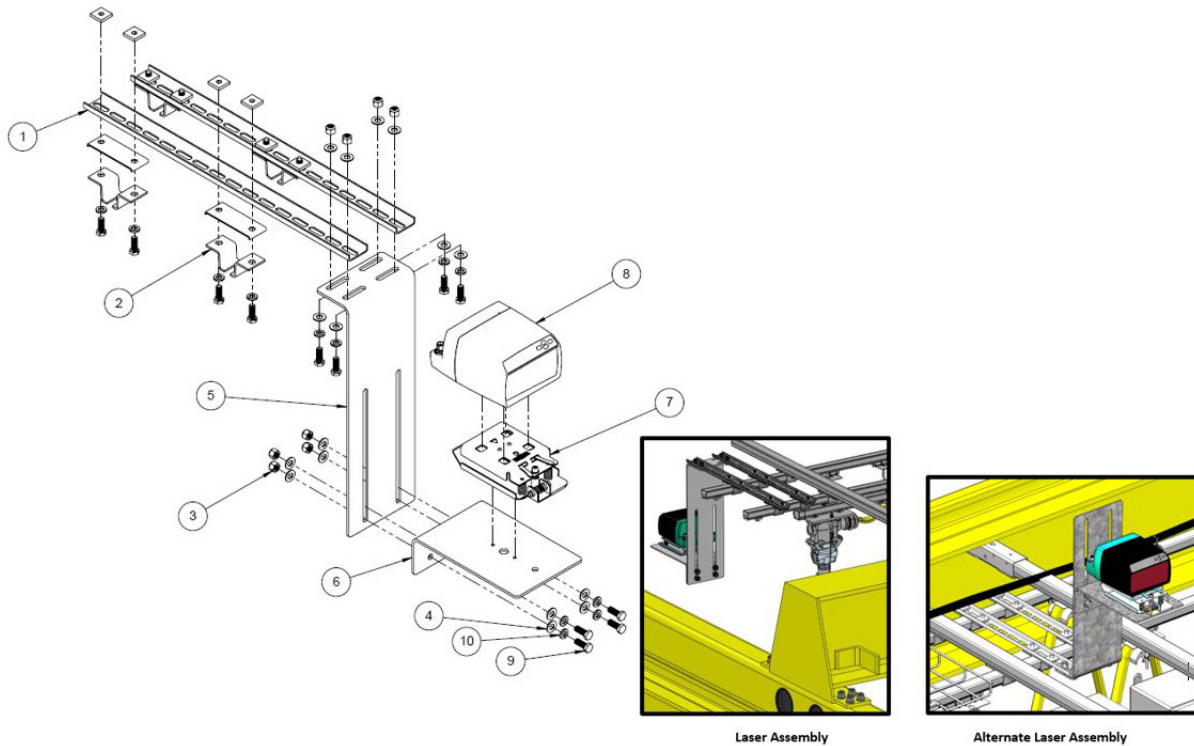

Item No.	Description	Qty
1	BKS-F24-G Flange Mount BR	2
2	F-CTH Low-Profile Hanger	4
3	Nut, Nylon, 3/8	8
4	Washer, 3/8 SAE	16
5	Bracket, Slotted, 150-300 m Sensor, Bridge Motion	1
6	Bracket, 150-300 m Sensor Mount, Bridge Motion	1
7	Bracket, 150-300 m Sensor Mount	1
8	Intelli-Protect Sensor	1
9	Hex Cap Screw, Shallow Head, 3/8-16 x 1	8
10	Lock Washer, 3/8	8

**Figure 2-13: Festoon Side Mounting**

## Weld Mount to Bridge Solution

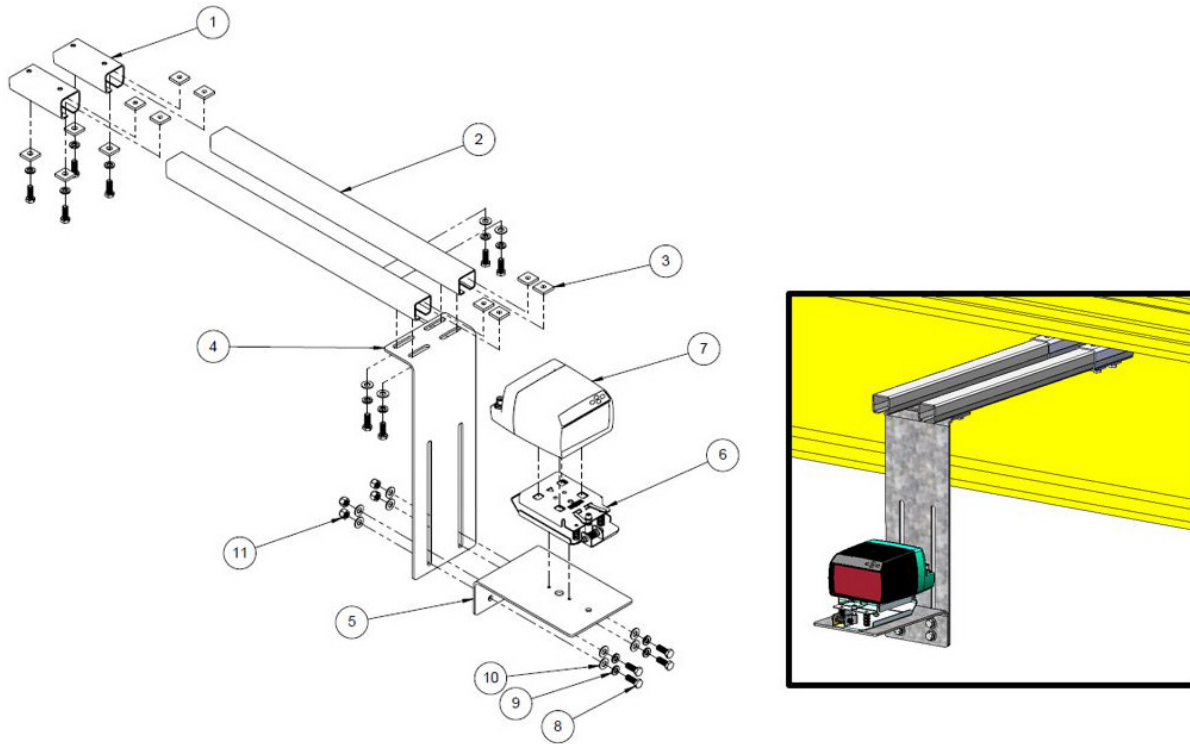

Item No.	Description	Qty
1	Weld Cross Arm Socket	2
2	F-12CT10 C-Track 12GA	2
3	F-A005C Square Nut Tapped	4
4	Bracket, Slotted, 150-300 m Sensor, Bridge Motion	1
5	Bracket, 150-300 m Sensor Mount, Bridge Motion	1
6	Bracket, 150-300 m Sensor Mount	1
7	Intelli-Protect Sensor	1
8	Hex Cap Screw, Shallow Head, 3/8-16 x 1	8
9	Lock Washer, 3/8	8
10	Washer, 3/8 SAE	12
11	Nut, Nylon, 3/8	4

**Figure 2-14: Non-festoon Side Mounting**

## 2.5.2 150 m and 300 m Laser Wiring

### 150–300m LASER OPTIONS

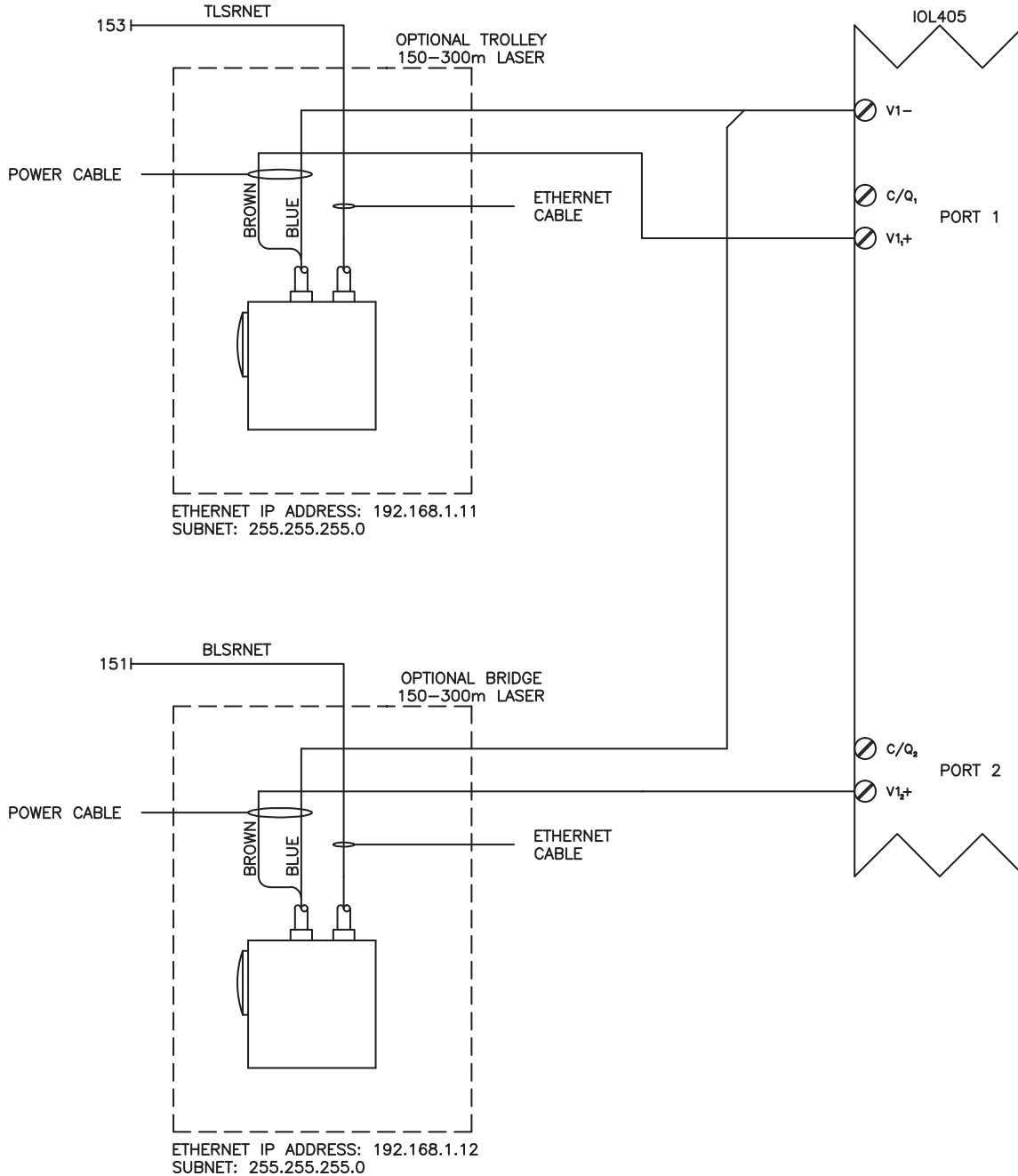

**Figure 2-15: 150 m and 300 m Laser Options**

## 2.6 Laser Alignment Instructions

1. The factory default setting for the laser pointer in the menu is “Auto.”
  - If the sensor does not detect a target, the laser pointer flashes at a frequency of approximately 1 Hz.
  - Perform the alignment at the maximum possible distance.
  
2. Align the sensor so that the red laser dot is as close to center of reflector as possible.
  - As soon as the distance measurement device has detected a target, the laser pointer flashes for an additional two minutes before deactivating automatically.
  - Run the crane to test and verify the laser dot remains on the reflector for the entire span of operation.

## 2.7 Light Stack Installation

The light stack that is provided with the Intelli-Protect No-Fly Zone, includes a horn to provide visual and audible notifications. Install the light stack in a location visible to the operator.

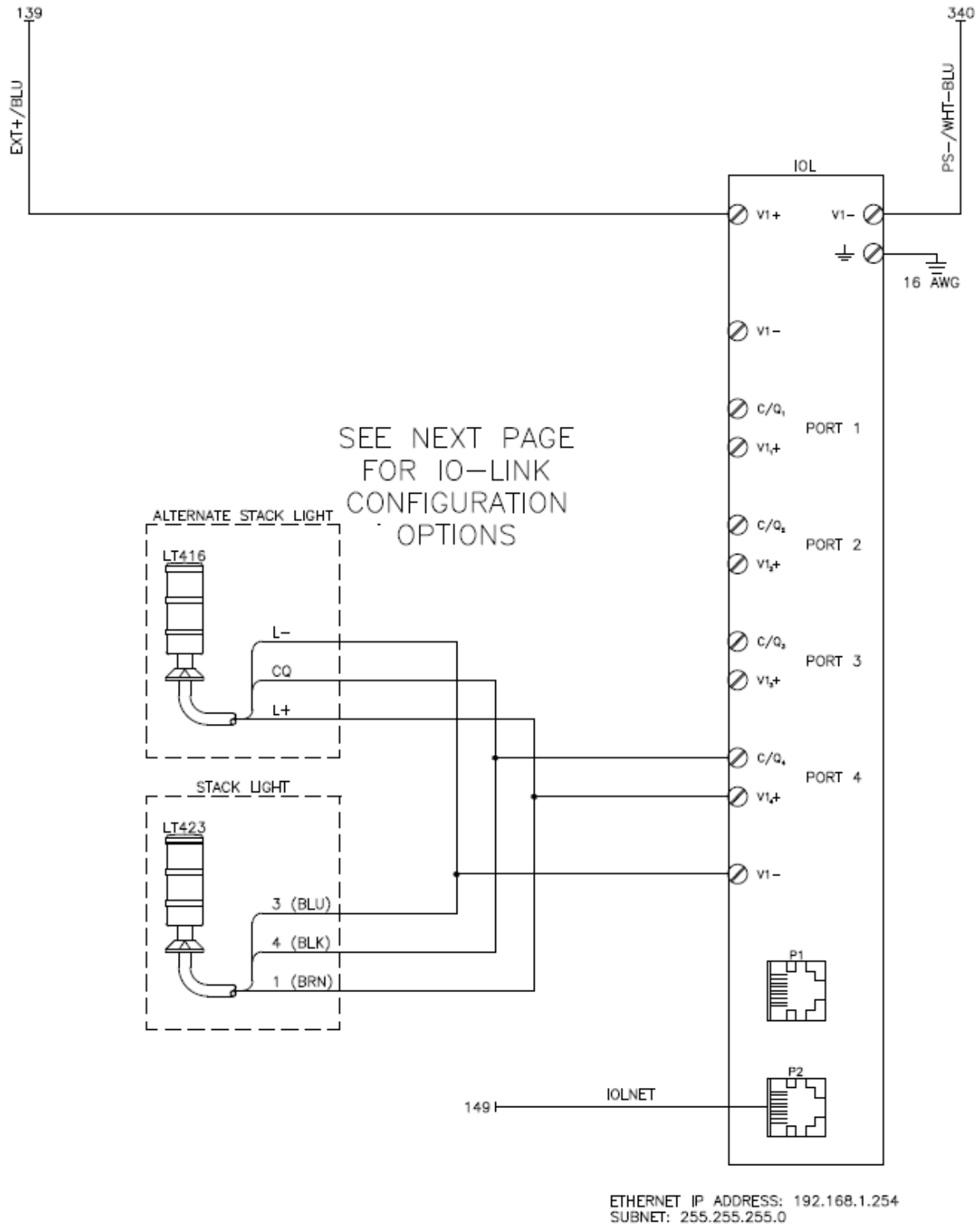

**Figure 2-16: Light Stack Install**



**Figure 2-17: Light Stack Install**

### 3 Power and Control Wiring

The following diagram shows terminal block connection points for power and control wiring for configurable No-Fly Zones. 115 VAC, 3 Amp, 60 Hz is customer supplied. Power and control wiring should follow all necessary national and local standards.

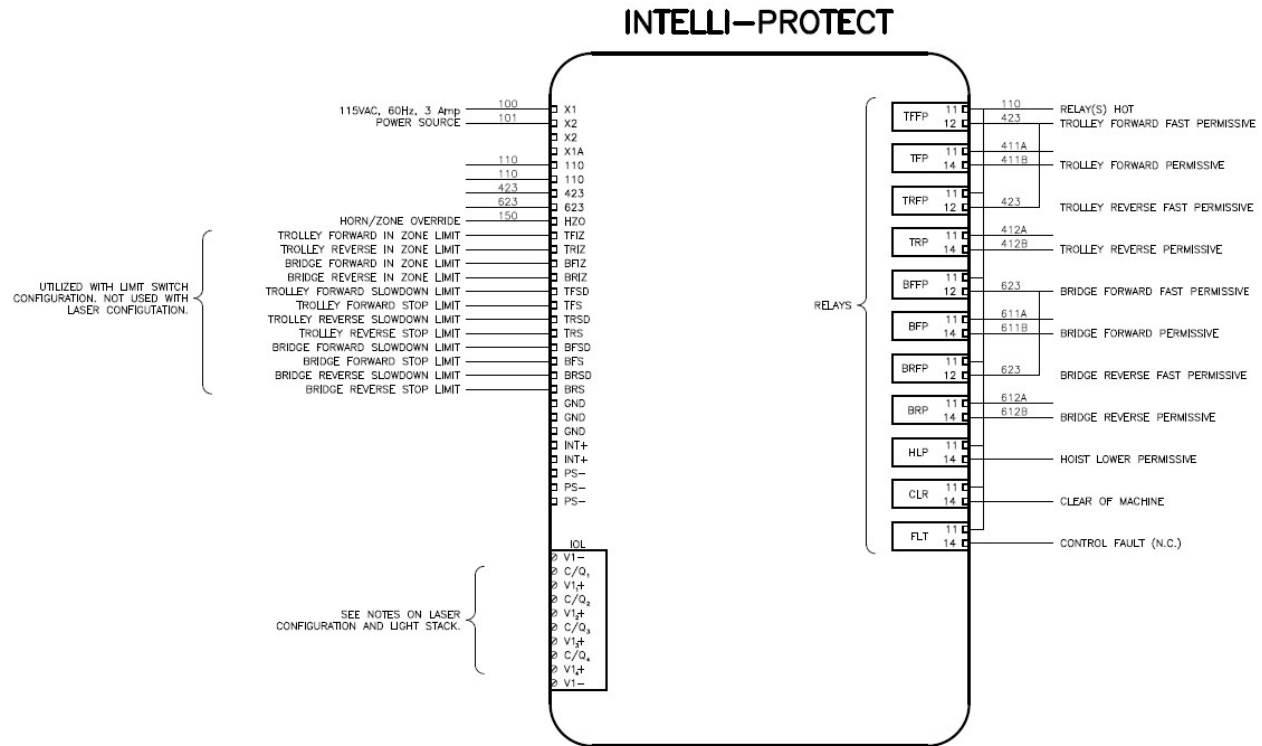

Figure 3-1: Terminal Block Connection Points

#### 3.1 Control Inputs

- Configurable systems connect directly from the field installed lasers to the IO-Link module (Protected, Stop, and Slow Down Zones are configured through the user interface)
- The light stack connects directly from the field installed light stack to the IO-Link module
- Horn/Zone Override input is an optional input for configurable No-Fly Zones to permit the crane to go over the top of a No-Fly Zone (needs to take into account all hoists and zones)
- Machine Down input is an optional input for configurable or fixed location No-Fly Zones to permit the crane to go over the top of a No-Fly Zone and is only available for Zone 1 (Field wiring and circuit design is done on site by the customer and needs to take into account all hoists and zones)
- The Machine Down input takes priority over the Hoist Upper Limit input (i.e., if the hoist is in upper limit and the machine is up, you will not be able to move the crane into the zone).
- Trolley and bridge wiring to external controller, variable frequency drives or contractor control are found in **Intelli-Protect Control Outputs on page 34**.
- Control Fault output for optional connection to a fault input on an external drive or to connect to other desired devices such as external enunciators in the event of an NFZ Fault. Faults include protected zone penetration, loss of laser communication, or other system faults.





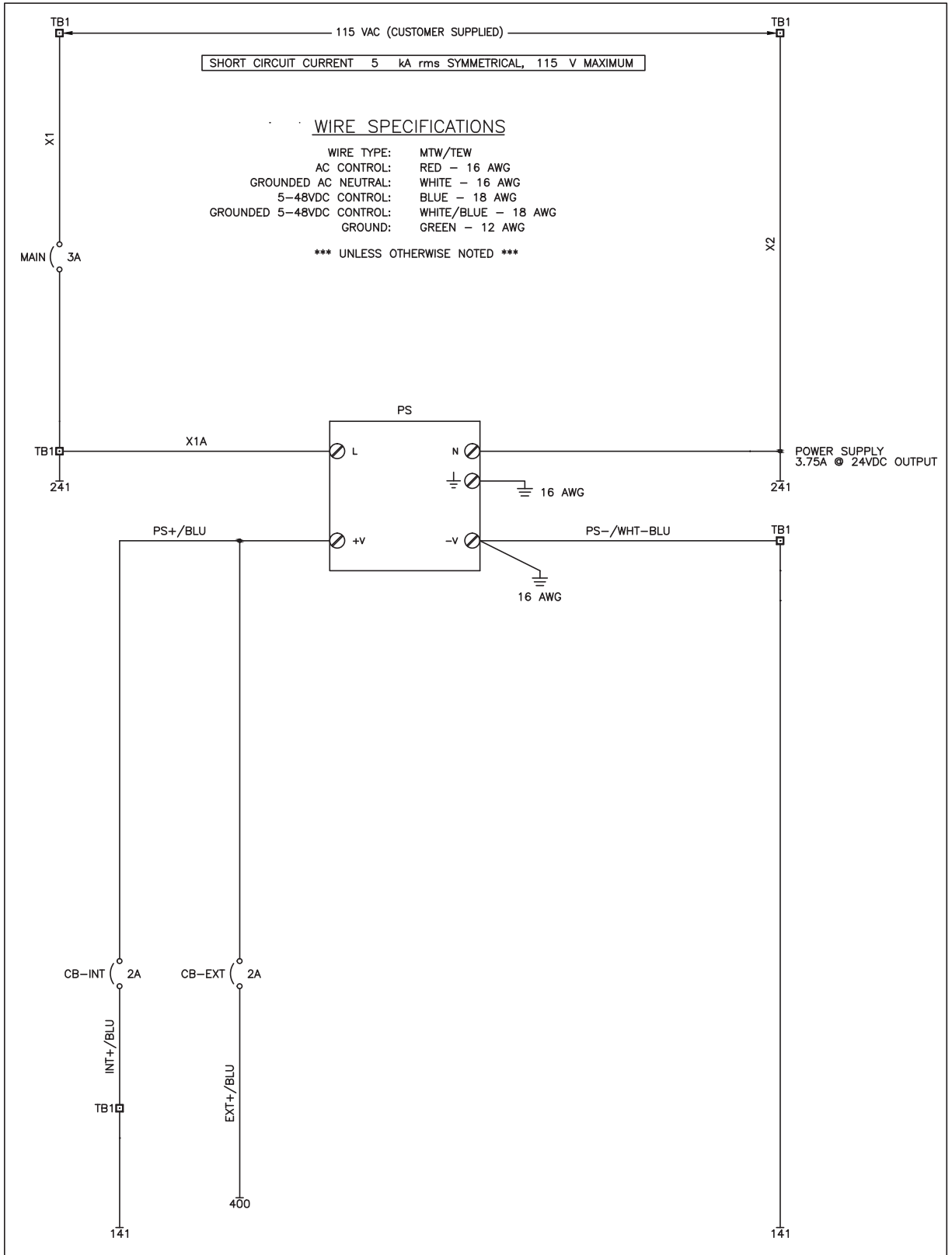

**Figure 3-3: Internal Power Diagram (for reference only)**

## 3.2 Intelli-Protect Control Outputs

Inside the system panel, locate the terminal block corresponding to the indicated relay labels. Factory-installed jumpers are included to provide discrete outputs for motor control side dry-contact inputs, which can be removed if wiring pendant or radio control signals through these relays.

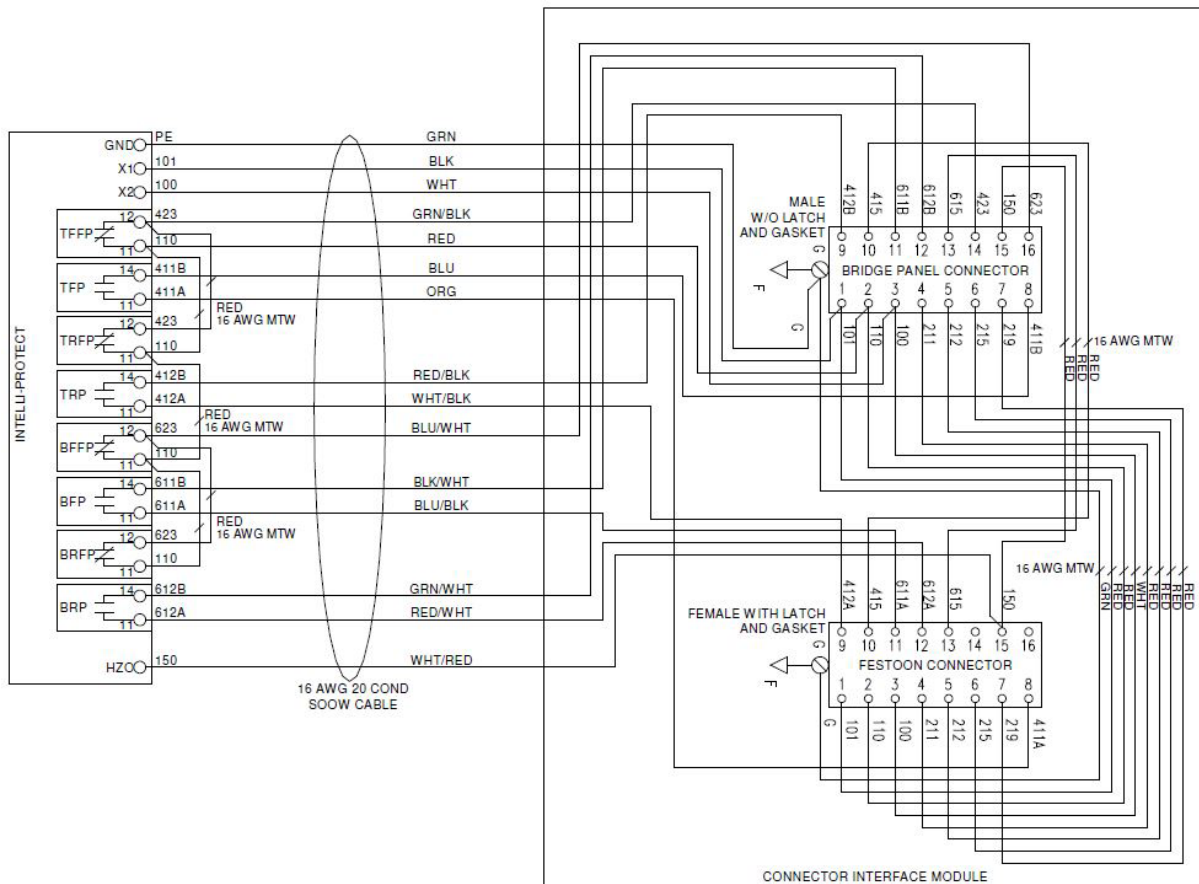

Figure 3-4: Relay Labels

### 3.2.1 Control Outputs

Designed for fail-safe operation, the control outputs are wired to a drive that controls the trolley, bridge and hoist motions. The Fast Permissive will allow the bridge or trolley to run at full speed when outside of the No-Fly Zone Slow Down Boundary. If the crane enters the Slow Down Zone these relays would change state. The Forward/Reverse Permissive will allow the bridge or trolley to run when outside of the No-Fly Zone Stop Boundary. If the crane enters the Stop Zone, these relays would change state.

- Forward / Reverse Fast Permissive used to allow the bridge or trolley to run at full speed
- Forward / Reverse Permissive used to allow the bridge or trolley to run
- Hoist Lower Permissive output provides a control signal to an external controller or hoist drive signaling that the crane and hoist are over the No-Fly Zone to prevent the hoist from lowering in the No-Fly Zone (used for both hoist upper limit and machine down configurations)
- Clear of Machine Permissive output provides a control signal to an external controller or hoist drive signaling that the crane and hoist is no longer above the machine.

## 4 Configurable No-Fly Zone Setup

### 4.1 Connecting to Web Server

#### Step 1. Set up network connection to the web server.

Ensure the wireless connection to your Intelli-Protect® panel is turned on and the control panel is powered up.

**NOTE:** You may disable the Intelli-Protect Wi-Fi system using the Wi-Fi key switch on the front panel after configuration to avoid interference with other wireless systems.



#### Step 2. Connect to the web server on the Programmable Logic Controller (PLC).

- a. Using your personal electronic device, smartphone, tablet, or PC, go into the Wi-Fi settings and locate the MagnetekNFZ network.
- b. Enter the default password: MagnetekNFZ.

#### Step 3. Open the NFZ Configuration page through the browser.

Open a browser such as Chrome, Safari, or Edge, and enter the following IP address in the search bar or scan QR code to access the configuration page:

IP Address 192.168.1.1:8080/webvisu.htm



#### Step 4. Use the No-Fly Zone Program to configure your No-Fly Zone system:

##### Monitor Screens

**Overview** – View all enabled No-Fly Zones

**Inputs** – View active state of Zone Bypass, Hoist Upper Limit, and Machine Lowered

**Outputs** – View active state of:

Trolley and Bridge Forward

Trolley and Bridge Forward Fast

Trolley and Bridge Reverse

Trolley and Bridge Reverse Fast

Hoist Lower

Clear of Machine

Control Fault

Light Stack: NFZ Ready, NFZ Stop, NFZ Slowdown, NFZ Fault, Zone Bypassed

**Alarms** – View active alarms

## Config Screens

**Trolley** – Setup Trolley Span, and Slow and Stop Distance

**Bridge** – Setup Bridge Span, and Slow and Stop Distance

**Zone** – Setup and enable / disable up to 31 No-Fly zones

## 4.2 Configurable Initial Setup

For initial setup and zone configuration the following steps should be implemented:

1. Power up the system
2. Status light Green for Power on, red flashing for no zones configured (NO FAULT) (No Horn)
3. Configure the bridge and trolley distances
4. Configure Zone 1
  - a. Teach corner 1 by moving the crane or entering the data manually
  - b. Teach corner 2 by moving the crane or entering the data manually
  - c. Enable Hoist Upper Limit if needed
  - d. Enable Machine Down if needed (Only Available in zone one)
5. Move the crane out of the zone
6. Enable the Zone 1 (Checkbox indicates zone is enabled with a check mark)
7. Status light Green (Amber if crane is still in the stop or slow down zone)
8. Test Zone
9. Repeat steps for Zones 2-27
10. Configure (4) End-of-Travel Zones. Zones 28-31

If all zones are disabled using the user interface, the green light will stay on and a red light will flash (no horn).

## 4.3 How to Configure Travel Limits

Before defining your custom NFZs, follow the steps below to set your unique trolley and bridge span for the bay the crane is operating in.

Each main menu button opens a screen that appears separately and includes specific programming steps.

Begin with establishing the length of the Trolley and Bridge limit. After setting the Bridge and Trolley limits, you may continue ahead to configure your custom NFZs.

### 1. Configuration of Trolley and Bridge Limit

- a. Press the **Trolley Config** button
- b. Follow the Trolley Configuration steps
- c. Press the **Bridge Config** button
- d. Follow the Bridge Configuration steps

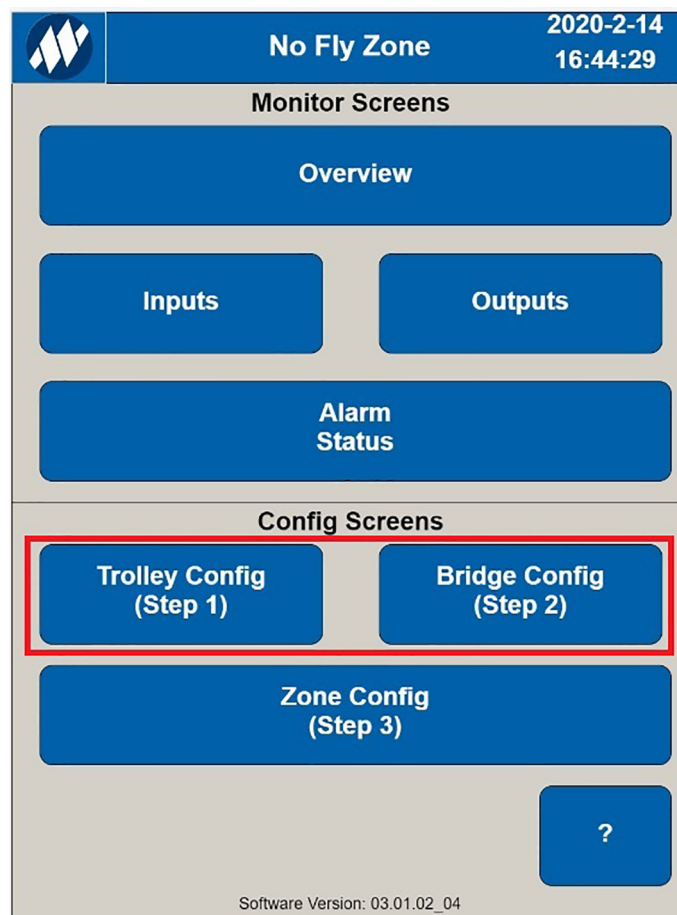

**Figure 4-1: Configuring Trolley and Bridge Limit**

### 4.3.1 Trolley Configuration Steps

Before defining the trolley limit, enter a description to explain the orientation of each side of the trolley such as “East” or “West.”

Position the trolley to the farthest position away from the trolley reflector so that the displayed laser value is maximum, and then press the Teach Max button to configure the max limit of the trolley.

If the trolley cannot be moved to the farthest position, enter a trolley position value manually.

Position the trolley to the shortest position, closest to the trolley reflector so that the displayed laser value is minimum, and then press the Teach Min button to configure the min limit of the trolley. If the trolley cannot be moved to the closest position, enter a trolley position value manually.



The slowdown and stop distances entered should be determined based on the crane speed and deceleration rate set by the motor drive. The values entered should be tested experimentally. It is best practice to set up a temporary test zone in an open area. After setting up this test zone, set the expected distances required to slow down and stop the crane. Once these values are entered, move the crane at maximum speed toward the test zone in order to determine if the slowdown distance value entered is large enough to slow down the crane to the slowdown speed before it enters the stop zone. Then determine if the stop distance value entered is large enough to stop the crane moving at the slowdown speed before it enters the protected zone. Modify the slowdown and stop distance values as needed and repeat these steps.

It is not recommended to use the no-load hook position when setting the NFZ corner boundaries. Doing this does not take into account the radius of the load; therefore, you will need to add the maximum radius of the load to both the stop and slowdown distances after determining the required distance values.

If using Magnetek Sway Control software, make sure to perform the slowdown and stop distance measurements and configuration with the Sway Control feature enabled. Using Sway Control with Intelli-Protect requires the most recent Magnetek VFD firmware release. Contact Magnetek for more details.

Step 1	Step 2	Step 3	Ac < >
--------	--------	--------	--------

### Trolley Config Help

**Step 1A**  
Enter the forward and reverse descriptions.

**Step 1B**  
Select the unit of measurement (mm, meters, inches, or feet) by tapping the field to the right of the trolley position.

**Step 1C**  
Move the trolley to the end of the bridge where the laser value is the maximum and press the Maximum Set Trolley Span button. If the trolley cannot be moved to the end of the bridge, enter the value manually.

**Step 1D**  
Move the trolley to the end of the bridge where the laser value is the minimum and press the Minimum Set Trolley Span button. If the trolley cannot be moved to the end of the bridge, enter the value manually.

**Step 1E**  
Enter the distance it takes the trolley to decelerate from full speed to slowdown speed. If the distance is unknown, it may take trial and error to determine the value.

**Step 1F**  
Enter the distance it takes the trolley to decelerate from slow speed to zero speed. If the distance is unknown, it may take trial and error to determine the value.

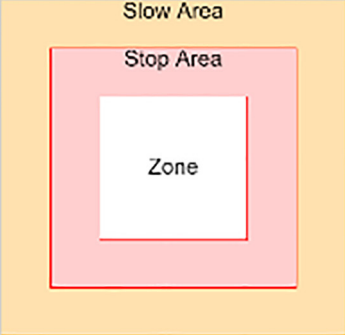

Slow Area

Stop Area

Zone

Back

**Figure 4-2: Zone Configuration**



## 1. Trolley Configuration

- a. Press the **Forward Description** text box
- b. Enter the desired description for Forward
- c. Press the **Reverse Description** text box
- d. Enter the desired description for Reverse
- e. Move Trolley to the End of Travel position where the laser value is the maximum
- f. Press the **Teach Max** button
- g. Move Trolley to the End of Travel position where the laser value is minimum
- h. Press the **Teach Min** button
- i. Enter a Slowdown Distance:
  - Distance it takes a trolley to decelerate from full speed to slowdown speed
- j. Enter a Stop Distance:
  - Distance it takes a trolley to decelerate from slowdown speed to zero speed

The screenshot shows a software interface for trolley configuration. At the top, there is a blue header with a logo on the left, the word "Trolley" in the center, and the date "2023-3-27" and time "8:54:44" on the right. Below the header, there are two rows of text boxes: "Forward Description" with the value "RIGHT" and "Reverse Description" with the value "LEFT". The next section is titled "Trolley Span (Scales Trolley on Overview Screen and sets up End Of Travel Limits)". It contains a "Trolley Position" field with the value "2.89 Feet". Below this are two blue buttons: "Teach Max" and "Teach Min". To the right of these buttons are two rows of text boxes: "Maximum" with the value "6.00 Feet" and "Minimum" with the value "0.50 Feet". The next section is titled "Slowdown/Stop Distance". It contains two rows of text boxes: "Slowdown Distance" with the value "1.00 Feet" and "Stop Distance" with the value "0.50 Feet". At the bottom, there are two blue buttons: "Main" and "?".

Figure 4-3: Configuring Trolley

### 4.3.2 Bridge Configuration Steps

Before defining the bridge limit, enter a description to explain the orientation of each side of the bridge such as “North” or “South.”

Position the bridge to the farthest position away from the bridge reflector so that the displayed laser value is maximum, and then press the Teach Max button to configure the max limit of the bridge.

Position the bridge to the shortest position away from the bridge reflector so that the displayed laser value is minimum, and then press the Teach Min button to configure the min limit of the bridge.



The slowdown and stop distances entered should be determined based on the crane speed and deceleration rate set by the motor drive. The values entered should be tested experimentally. It is best practice to set up a temporary test zone in an open area. After setting up this test zone, set the expected distances required to slow down and stop the crane. Once these values are entered, move the crane at maximum speed toward the test zone in order to determine if the slowdown distance value entered is large enough to slow down the crane to the slowdown speed before it enters the stop zone. Then determine if the stop distance value entered is large enough to stop the crane moving at the slowdown speed before it enters the protected zone. Modify the slowdown and stop distance values as needed and repeat these steps.

It is not recommended to use the no-load hook position when setting the NFZ corner boundaries. Doing this does not take into account the radius of the load; therefore, you will need to add the maximum radius of the load to both the stop and slowdown distances after determining the required distance values.

If using Magnetek Sway Control software, make sure to perform the slowdown and stop distance measurements and configuration with the Sway Control feature enabled. Using Sway Control with Intelli-Protect requires the most recent Magnetek VFD firmware release. Contact Magnetek for more details.

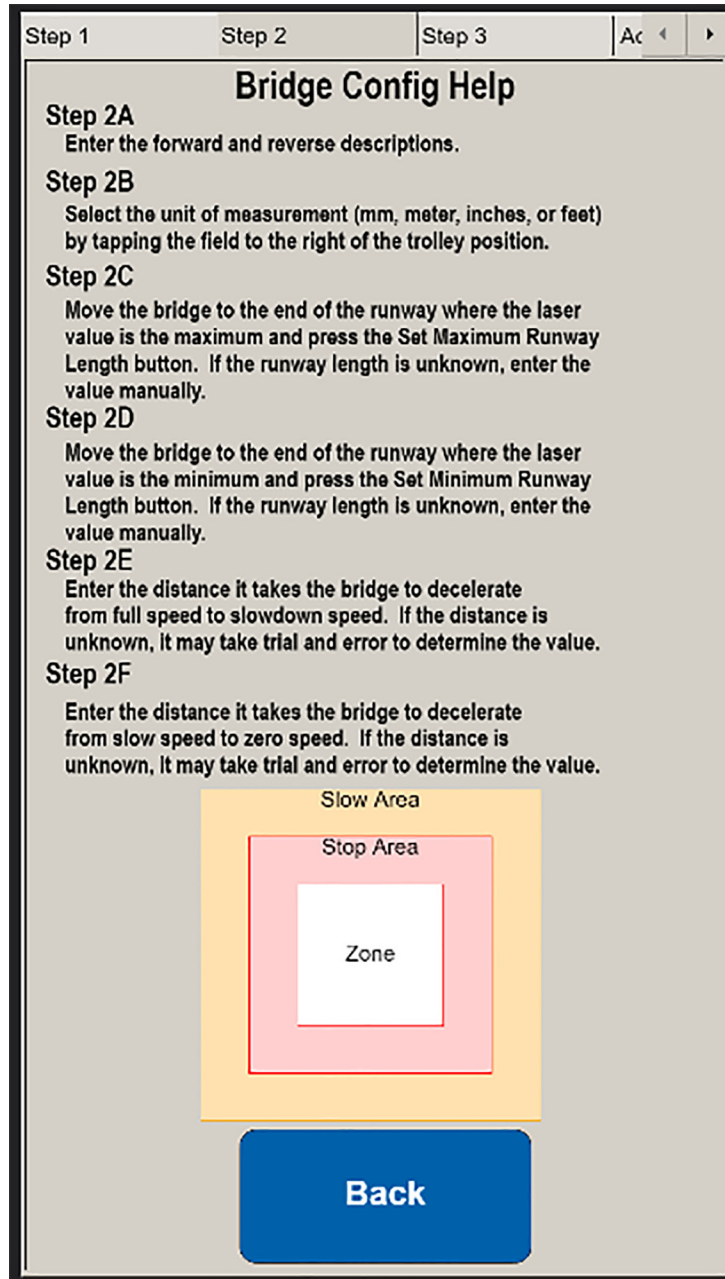

**Figure 4-4: Zone Configuration**

## 1. Bridge Configuration

- a. Press the **Forward Description** text box
- b. Enter the desired description for Forward
- c. Press the **Reverse Description** text box
- d. Enter the desired description for Reverse
- e. Move Bridge to the End of Travel position where the laser value is the maximum
- f. Press the **Teach Max** button
- g. Move Bridge to the End of Travel position where the laser value is minimum
- h. Press the **Teach Min** button
- i. Enter a Slowdown Distance:
  - Distance it takes the bridge to decelerate from full speed to slowdown speed
- j. Enter a Stop Distance:
  - Distance it takes the bridge to decelerate from slowdown speed to zero speed

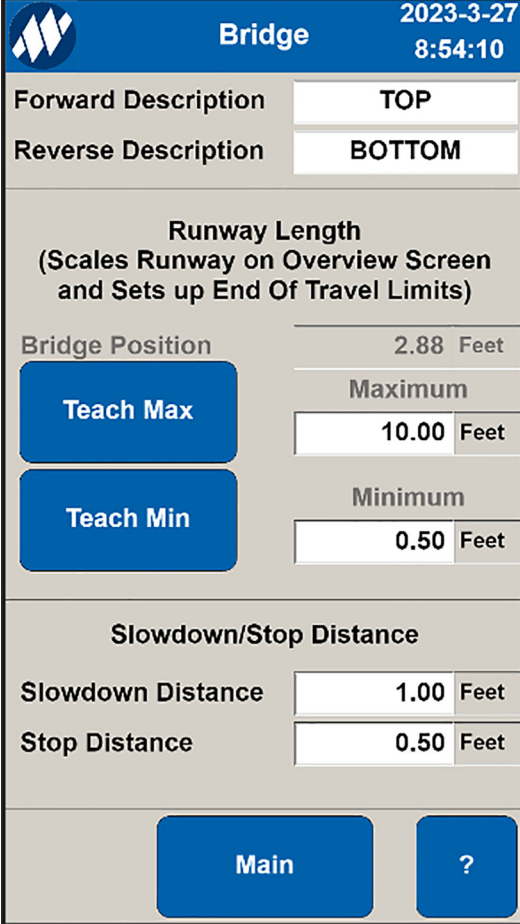

The screenshot shows a configuration screen for a bridge. At the top, there is a blue header with a logo on the left, the word "Bridge" in the center, and the date "2023-3-27" and time "8:54:10" on the right. Below the header, there are two rows of text boxes: "Forward Description" with the value "TOP" and "Reverse Description" with the value "BOTTOM". The next section is titled "Runway Length (Scales Runway on Overview Screen and Sets up End Of Travel Limits)". It contains a "Bridge Position" field with the value "2.88 Feet". Below this are two blue buttons: "Teach Max" and "Teach Min". To the right of these buttons are two input fields: "Maximum" with the value "10.00 Feet" and "Minimum" with the value "0.50 Feet". The next section is titled "Slowdown/Stop Distance". It contains two rows of text boxes: "Slowdown Distance" with the value "1.00 Feet" and "Stop Distance" with the value "0.50 Feet". At the bottom of the screen, there are two blue buttons: "Main" and "?".

Figure 4-5: Configuring Bridge

## 4.4 Zone Setup

To configure the location of a No-Fly Zone, first disable the zone by clearing the 'Enable' checkbox. On initial setup, all zones are disabled by default. Each zone is numbered from 1 to 31. Use the Previous and Next buttons at the top of the menu to scroll between all 31 zone configurations.

Each zone displays a user-customizable ID descriptor or name for added clarity.

Position the hoist at one corner of the desired zone and press the **Teach Initial Corner** button to store the initial corner position of the zone.

Position the hoist at the diagonal corner of the desired zone and press the **Teach Diagonal Corner** button to store the corner position and finalize the zone.

If needed the data can be entered manually by pressing on the measurement. The value entered can be beyond the configured travel limits.

### 1. Zone Configuration

- a. Press the previous or next buttons until the desired zone number appears
- b. Press the Enable button to remove the checkbox if enabled
- c. Move hoist to one corner
- d. Press **Teach Initial Corner** button
- e. Move hoist to opposite diagonal corner
- f. Press **Teach Diagonal Corner** button
- g. Move the hoist away
- h. Press the Enable button to enable zone protection
- i. Press the ID field to enter a name

The screenshot shows the 'Zone 1 Config' screen with a date and time of 2023-4-13 12:35:09. At the top are 'Previous' and 'Next' buttons. Below is an 'ID' field containing 'South Wall'. There is an 'Enable' checkbox which is currently unchecked, and an 'Advanced Setup' button. The screen displays 'Trolley Position' at 3.22 Feet and 'Bridge Position' at 3.03 Feet. There are two 'Teach' buttons: 'Teach Initial Corner' and 'Teach Diagonal Corner'. Each has 'T' and 'B' options with input fields showing 10.00 Feet and 5.00 Feet respectively. At the bottom are 'Main' and '?' buttons.

Figure 4-6: Configuring and Enabling a Zone

### 4.4.1 Load Size Consideration

When configuring the No-Fly Zone, the dimensions of the material being moved by the overhead crane and hoist needs to be considered. The length and width of the largest materials being moved should guide the design of the zone to allow enough distance for slow down zone, stop zone and protected zone. In addition to the length and width, the height of the material needs to be taken into account for fly-over No-Fly Zones when using the Hoist Upper Limit input or Machine Down input to insure proper clearance over the top of the protected zone.

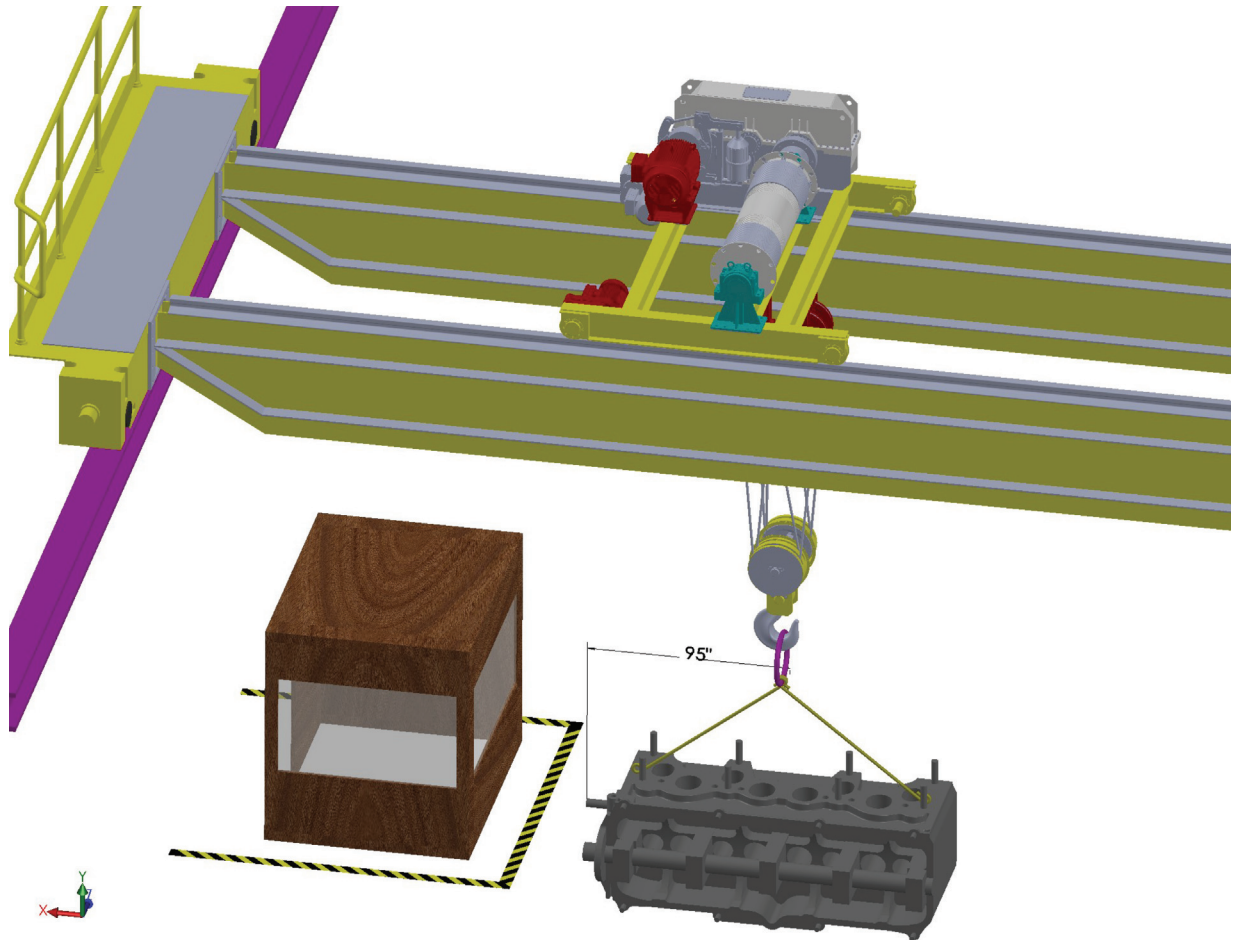

Figure 4-7: Load Size Consideration

## 4.5 Enabling Zones

After completing the setup of the trolley, bridge spans, the Slow Down Zone, Stop Zone and Protected Zone, press the enable button on the configuration screen. The enabled zone will now appear on the Overview screen. Use the enable/disable checkbox for maintenance in a zone, changing the dimensions or moving the zone to a new location.

Trolley and Bridge Corner zone values may be edited manually when a zone is enabled. Press the desired value to change.

The screenshot shows a mobile application interface for configuring a zone. At the top, it says 'Zone 1 Config' with a date and time of '2023-3-27 9:29:01'. There are 'Previous' and 'Next' buttons. The 'ID' field is set to 'South Wall'. An 'Enable' checkbox is checked. An 'Advance Setup' button is present. Below this, 'Trolley Position' is set to '2.89 Feet' and 'Bridge Position' is set to '2.88 Feet'. There are two sections for teaching corners: 'Teach Initial Corner' and 'Teach Diagonal Corner'. Each has 'T' and 'B' options with input fields. For 'Teach Initial Corner', both 'T' and 'B' are set to '10.00 Feet'. For 'Teach Diagonal Corner', both 'T' and 'B' are set to '5.00 Feet'. At the bottom, there are 'Main' and '?' buttons.

Field	Value
ID	South Wall
Enable	<input checked="" type="checkbox"/>
Trolley Position	2.89 Feet
Bridge Position	2.88 Feet
Teach Initial Corner (T)	10.00 Feet
Teach Initial Corner (B)	10.00 Feet
Teach Diagonal Corner (T)	5.00 Feet
Teach Diagonal Corner (B)	5.00 Feet

Figure 4-8: Enabling a Zone

## 4.6 Hoist Upper Limit and Machine Down Configuration

A No-Fly Zone can be bypassed by selecting the Hoist Upper Limit checkbox on the zone configuration screen. The input is provided by the customer to the NFZ controller by the horn pushbutton. When the override is active the horn will also sound.

The Machine Down checkbox on Zone One is available for optional use but is not part of the default wiring.



# CAUTION

When configuring the No-Fly Zone, consider the dimensions of the material being moved by the overhead crane and hoist. The length and width of the largest materials being moved should guide the design of the zone to allow enough distance for slow down zone, stop zone and protected zone. When an override is activated all zones with the Hoist Upper Limit checkbox checked will be disabled. The horn serves as a reminder to observe caution while zones are disabled.

**Zone 1 Advanced**2023-4-13  
12:36:45

PreviousNext

ID:

Hoist Upper Limit  
 Machine Down  
 Slowdown Only

**Trolley Additional**

Slowdown Distance  Feet  
Stop Distance  Feet

**Bridge Additional**

Slowdown Distance  Feet  
Stop Distance  Feet

Back?

**Zone 1 Advanced**2023-4-13  
12:47:50

PreviousNext

ID:

Hoist Upper Limit  
 Machine Down  
 Slowdown Only

**Trolley Additional**

Slowdown Distance  Feet  
Stop Distance  Feet

**Bridge Additional**

Slowdown Distance  Feet  
Stop Distance  Feet

Back?

Figure 4-9: Hoist Upper Limit and Machine Down Configuration



## 4.7 Slowdown Only Configuration

A Slowdown Only Zone option can be configured for every zone. When the crane enters the slowdown only zone, the crane will slowdown but it will not stop. Additionally, slowdown only zones can be configured to allow fast motion in either the bridge or trolley direction. This is useful in cases where you want to enter a slowdown zone quickly, and then limit the speed of the other direction once you are in the slowdown zone.

The figure shows three sequential screenshots of the 'Zone 1 Advanced' configuration interface for 'South Wall'. Each screen has a 'Previous' and 'Next' button at the top. The configuration options are as follows:

- Screen 1 (12:48:42):** 'Slowdown Only' is checked. 'Allow Fast Trolley Motion' and 'Allow Fast Bridge Motion' are unchecked.
- Screen 2 (12:49:18):** 'Slowdown Only' is checked. 'Allow Fast Trolley Motion' is checked. 'Allow Fast Bridge Motion' is unchecked.
- Screen 3 (12:49:47):** 'Slowdown Only' is checked. 'Allow Fast Trolley Motion' is unchecked. 'Allow Fast Bridge Motion' is checked.

Below the checkboxes, there are sections for 'Trolley Additional' and 'Bridge Additional', each with 'Slowdown Distance' and 'Stop Distance' fields, all set to '0.00 Feet'. At the bottom of each screen are 'Back' and '?' buttons.

Figure 4-10: Slowdown Only Configuration



### CAUTION

If Zone is set to Slowdown Only, the crane will not stop when it enters the zone. Ensure zone area is safe for entry when this option is selected.

## 4.8 Zone Overview

The Zone Overview screen displays the position, relative size and state of all enabled NFZs.

If a hoist moves into the slowdown region of a zone, the icon will display a blinking AMBER Zone.

If a hoist crosses into the stop region, the icon will display a solid AMBER Zone.

A fault will occur if the NFZ protected boundary is penetrated. The icon background will change to RED.

### 1. Zone Overview

- a. All enabled zones appear on this view
- b. Each zone displays a unique zone number
- c. Each zone displays a color code:
  - GREEN = NORMAL
  - BLINKING AMBER = INSIDE SLOWDOWN BOUNDARY
  - SOLID AMBER = INSIDE STOP BOUNDARY
  - RED = ZONE BREACHED
  - FLASHING RED = BYPASSED

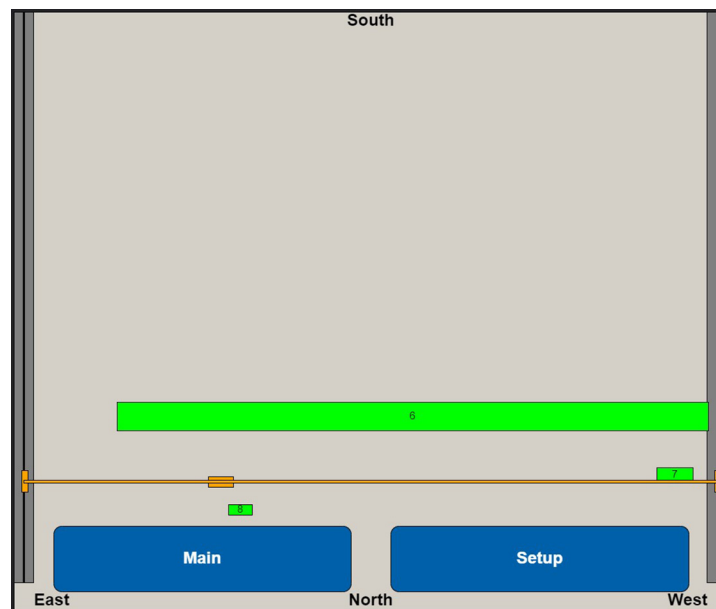
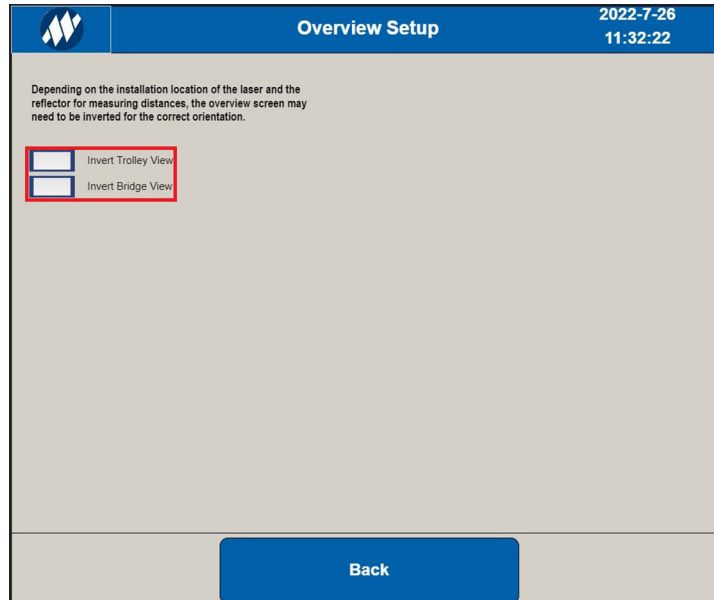

Figure 4-11: Zone Overview



**Figure 4-12: Zone Overview Setup**

# 5 Intelli-Protect® Inputs and Outputs

Intelli-Protect® supports the following system inputs and outputs that provide status indicators to aid in setup and troubleshooting:

## 1. Inputs

### a. Zone Bypass Indicator

BLUE = NFZ is Disabled (Bypass Key is Enabled)

WHITE = NFZ is Enabled (Bypass Key is Disabled)

### b. Hoist Upper Limit Indicator

WHITE = Hoist Lowered

BLUE = Hoist at upper limit

### c. Machine Down / Lowered Indicator

WHITE = Machine up

BLUE = Machine lowered

### d. Trolley and Bridge Motions

Forward, Reverse, Slow Down, Stop and In Zone indications

WHITE = OK (clear of zone)

BLUE = Slow down zone

BLUE = Stop zone



Figure 5-1: Intelli-Protect Inputs

The output screen provides status indication for outputs from the No-Fly Zone controller. The indicators will match the external light stack provided with the system.

## 1. Outputs

### a. Bridge and Trolley Motion

GREEN = Fast Permissive active  
 GREEN = Permissive active  
 WHITE = Inactive

### b. Hoist Lower Permissive

GREEN = Allowed  
 WHITE = Not Allowed

### c. Clear of Machine

GREEN = Clear  
 WHITE = Not Clear

### d. Control Fault

WHITE = OK  
 RED = Fault with control

### e. NFZ Ready

GREEN = Power on and booted

### f. Zone Occupied

SOLID AMBER = Stop  
 FLASHING AMBER = Slow

### g. NFZ Fault

RED = System Faulted

### h. Zone Bypassed

FLASHING RED = Bypass Key  
 Switch Disabled

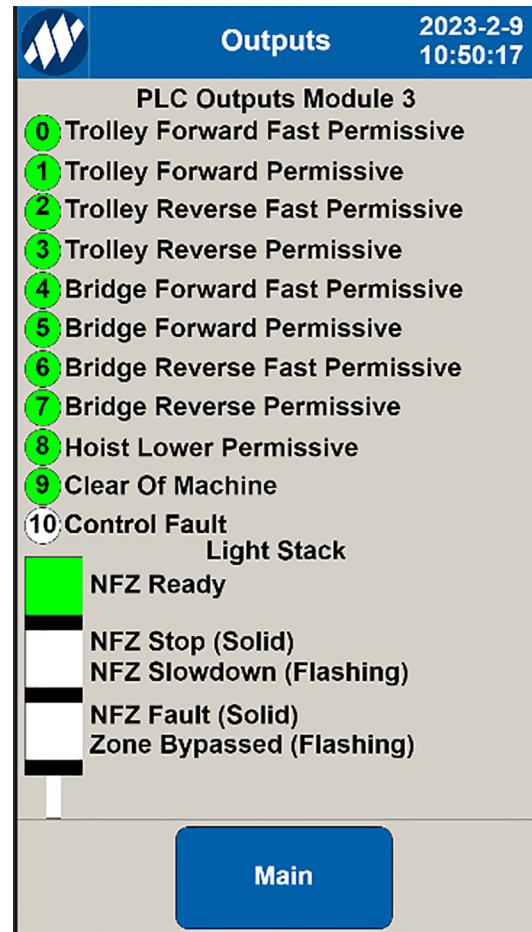

Figure 5-2: Intelli-Protect Outputs

## 6 Troubleshooting

### 6.1 Light Stack Indicators and Corrective Actions

Light Stack Fault Indicator	Fault Name / Description	Corrective Action
Solid Red light on Light Stack DANGER	<b>Zone [number] Breached</b> appears in Alarm List.	<ol style="list-style-type: none"> <li>1. Disable the No-Fly Zone using the key switch on the front of the enclosure</li> <li>2. Manually move the crane out of the zone</li> <li>3. Adjust zone dimensions, slow down distance, or stop distance</li> <li>4. Enable the No-Fly Zone by turning key switch to Normal on front of the enclosure</li> </ol>
Flashing or Solid Amber light on Light Stack WARNING	The hoist has entered the slowdown or stop region of a zone.	<ol style="list-style-type: none"> <li>1. Review the zone dimensions and adjust as needed for slow down and stop distances.</li> </ol>
Flashing Red light on Light Stack	The NFZ system has been bypassed or no protection zones are enabled.	<ol style="list-style-type: none"> <li>1. The key switch on the front of the enclosure is set to bypass the No-Fly Zone protection</li> <li>2. All zones have been disabled using the user interface</li> </ol>

- **Green Light**

- A green light indicates power has been applied to the controller, and the system is in normal operating mode.

- **Amber Light**

- The amber light flashes when the slowdown limit switch is triggered, or the distance measured with the laser indicates the trolley or bridge motion has crossed into a slowdown area. The amber light changes to steady state if the stop area is entered.
- The amber light is turned off when in normal operation outside of a No-Fly Zone.

- **Red Light**

- The red light turns on when a fault occurs in the controller or laser, or when the protected zone is breached. The red light stays solid red until a breach or other fault is cleared. In this state all control is stopped until the fault has been cleared.
- The red light also flashes if no zones are configured such as on initial startup. In this state the red light will flash until at least one zone is enabled.
- The red light is turned off when in normal operation outside a No-Fly Zone, and when there is no fault with the lasers or controller.

## 6.2 Alarms and Corrective Actions During Operation

Example alarms on configurable systems:

Active Alarms		2020-1-29 14:42:10	
	Date	Time	Description
0	2020-1-29	14:31:29	Bridge Sensor Fault
1	2020-1-29	14:31:29	Bridge Sensor Communication Fault
2			
3			
4			
5			
6			
7			
8			
9			
10			
11			
12			
13			
14			
15			
16			
17			
18			
19			
20			
21			
22			

Active Alarms		2020-2-14 14:50:25	
	Date	Time	Description
0	2020-2-14	14:50:09	Trolley Forward Limit Switch Fault
1			
2			
3			
4			
5			
6			
7			
8			
9			
10			
11			
12			
13			
14			
15			
16			
17			
18			
19			
20			
21			
22			

Figure 6-1: Alarm Examples

Alarm	Description	Corrective Action
Bridge Sensor Fault Trolley Sensor Fault	Sensor is not receiving a strong enough signal.	<ol style="list-style-type: none"> <li>Clean the Bridge or Trolley laser lens with a lens tissue or cleaning cloth. Using a circular motion, gently remove oil, fingerprints, and grime from the lens surface.</li> <li>Clean the reflector surface to remove oil, fingerprints, and grime.</li> </ol>
Bridge Sensor Communication Fault	Sensor is not receiving expected information.	<ol style="list-style-type: none"> <li>Check the ethernet cable connection to the Bridge laser.</li> <li>Check the external components circuit breaker.</li> </ol>
Trolley Sensor Communication Fault	Sensor is not receiving expected information.	<ol style="list-style-type: none"> <li>Check the ethernet cable connection to the Trolley laser.</li> <li>Check the external components circuit breaker.</li> </ol>

The Alarms screen button only displays all currently active alarms.

# 7 Other Features

## 7.1 Horn/Zone Override

An optional Horn/Zone Override input is available on the Power and Control Wiring terminal block for all zones. Select the UI Zone Configuration checkbox “Hoist Upper Limit” to override the selected zone. This is available on each configurable zone.

The screenshot shows a mobile application interface for configuring Zone 1. At the top, there is a blue header with a logo on the left, the text "Zone 1 Advanced" in the center, and the date "2023-4-13" and time "12:36:45" on the right. Below the header are two blue buttons: "Previous" on the left and "Next" on the right. The main content area has a light gray background. It starts with "ID:" followed by a white text box containing "South Wall". Below this are three checkboxes: "Hoist Upper Limit" (checked with a green checkmark), "Machine Down" (unchecked), and "Slowdown Only" (unchecked). The screen is divided into two sections: "Trolley Additional" and "Bridge Additional". Each section has two rows of input fields: "Slowdown Distance" and "Stop Distance", both set to "0.00 Feet". At the bottom, there are two blue buttons: "Back" on the left and "?" on the right.

**Figure 7-1: Hoist Upper Limit Switch**



## 7.2 Machine Lowered Example

An optional Machine Lowered input is available on the Power and Control Wiring terminal block. The Machine Lowered input will allow the crane operator to fly over the top of a No-Fly Zone. This is available on Zone 1 only of the configurable No-Fly Zones.



**Figure 7-2: Machine-Lowered Input**

Wire the Machine Down contact to the Machine-Lowered input on (MACH) terminal located on the Power and Control Wiring terminal block if used.

2023-4-13  
12:47:50

Zone 1 Advanced

Previous

Next

**ID:**

Hoist Upper Limit  
 Machine Down  
 Slowdown Only

Trolley Additional

Slowdown Distance	0.00	Feet
Stop Distance	0.00	Feet

Bridge Additional

Slowdown Distance	0.00	Feet
Stop Distance	0.00	Feet

Back

?

Figure 7-3: Advanced Setup Machine Down

### 7.3 Slowdown Only Configuration

A Slowdown Only Zone option can be configured for every zone. This zone type does not cause the crane to come to a complete stop. It can be enabled to trigger slowdown in the trolley direction or the bridge direction or both trolley and bridge directions while within the zone.

CAUTION

If Zone is set to Slowdown Only, the crane will not stop when it enters the zone. Ensure zone area is safe for entry when this option is selected.

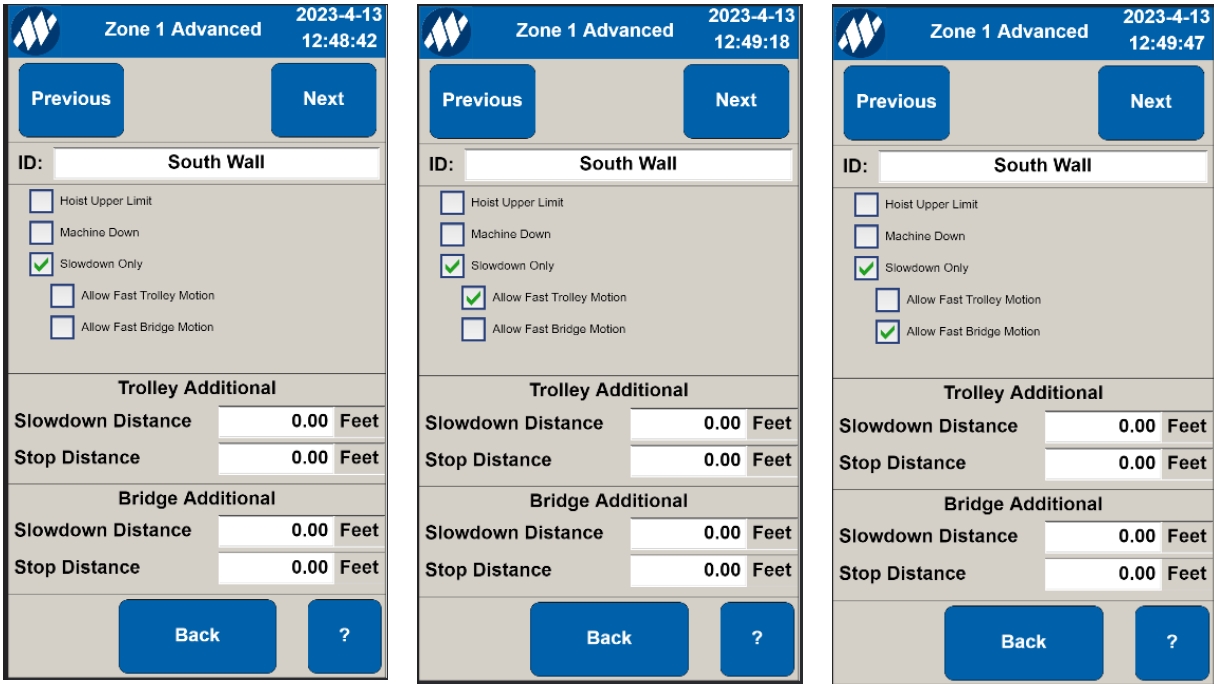



Figure 7-4: Advanced Setup Slowdown Only

## 7.4 Additional Slowdown and Stop Distances

Slowdown and Stop Distances are setup in the Trolley and Bridge configuration menus. These distances apply to all zones and need to be setup according to the speed and deceleration rates of the crane (they also need to factor in the dimensions of the load). In the 'Advanced Setup' menus (for each zone) the system allows you to include additional slowdown and/or stop distances for each individual zone.

## 7.5 End of Travel Zones

- Zones 28 through 31 will be dedicated for End of Travel Zones, which will prevent the crane from running into the end stops.
- These End of Travel Zones will be disabled by default.
- During commissioning, the system requires the user to teach the minimum and maximum Trolley positions as well as the minimum and maximum Bridge positions. The system will use these values to automatically program the End of Travel Zone coordinates.
- These End of Travel Zones coordinates can be adjusted as needed, similarly to all other zones.

 **Zone 28 Config** 2023-4-13 12:51:27

**Previous** **Next**

ID:

Enable **Advanced Setup**

Trolley Position  Feet

Bridge Position  Feet

**Teach Initial Corner**

T	<input type="text" value="2.00"/>	Feet
B	<input type="text" value="2.00"/>	Feet

**Teach Diagonal Corner**

T	<input type="text" value="114.83"/>	Feet
B	<input type="text" value="0.00"/>	Feet

**Main** **?**

 **Zone 28 Advanced** 2023-4-13 12:51:59

**Previous** **Next**

ID:

Hoist Upper Limit

Slowdown Only

**Trolley Additional**

Slowdown Distance	<input type="text" value="0.00"/>	Feet
Stop Distance	<input type="text" value="0.00"/>	Feet

**Bridge Additional**

Slowdown Distance	<input type="text" value="0.00"/>	Feet
Stop Distance	<input type="text" value="0.00"/>	Feet

**Back** **?**

**Figure 7-5: EOT Zone 1 and EOT Zone 1 Advanced**

## 8 Appendix

### 8.1 Wireless SSID Setup and Password

1. Using a web browser such as Internet Explorer, Chrome or Edge, type: 192.168.1.4 (default web server IP address).
2. Enter login id: magnetek, password: magnetek.
3. Select Wireless tab ->**Basic Settings** to change SSID.

The screenshot shows the Antaira Control Panel interface. The top navigation bar includes 'Setup', 'Wireless', 'Services', 'Port Forwarding', 'Administration', and 'Status'. Below this, there are sub-tabs for 'Basic Settings', 'Wireless Security', 'MAC Filter', and 'WDS'. The 'Basic Settings' tab is active, and a 'Wireless site survey' button is visible. The main configuration area is titled 'Wireless Physical Interface ath0 [2.4 GHz]'. Underneath, there is a section for 'Physical Interface ath0 - SSID [MagnetekNFZ] HWAddr [C4:93:00:0C:09:8B]'. This section contains several settings: 'Wireless Mode' (AP), 'Wireless Network Mode' (Mixed), 'Channel Width' (Full (20 MHz)), 'Wireless Channel' (Auto), 'Wireless Network Name (SSID)' (MagnetekNFZ), 'Wireless SSID Broadcast' (Enable), and 'Advanced Settings' (checkbox). The 'Wireless Network Name (SSID)' field is highlighted with a red box. Below this is the 'Radio Time Restrictions' section with a 'Radio Scheduling' option (Disable). At the bottom, there is a 'Virtual Interfaces' section with an 'Add' button and a footer with 'Save', 'Apply Settings', and 'Cancel Changes' buttons.

**NOTE:** After applying settings, press “Save” to ensure changes are saved in the event of power loss.

4. Select Wireless tab -> **Wireless Security** to change password.

The screenshot displays the Antaira Control Panel interface. At the top, the 'Wireless' tab is selected, and the 'Wireless Security' sub-tab is active. The configuration is for the physical interface 'ath0' with SSID '[MagnetekNFZ]' and HWAddr '[C4:93:00:0C:09:8B]'. The Security Mode is set to 'WPA'. Under 'Network Authentication', 'WPA2 Personal' is selected. Under 'WPA Algorithms', 'CCMP-128 (AES)' is selected. The 'WPA Shared Key' field contains 'MagnetekNFZ' and the 'Unmask' checkbox is checked. The 'Key Renewal Interval' is set to 3600 seconds, and 'Disable EAPOL Key Retries' is set to 'Disable'. At the bottom, there are 'Save' and 'Apply Settings' buttons.



Intelli-Protect® Technical Manual  
Part Number 1920887204 Rev AC  
April 2023



---

COLUMBUS MCKINNON FAMILY OF BRANDS

---

