

# SPARK RESISTANT

- BRONZE WHEELS
- STAINLESS STEEL DROP STOPS
- ALUMINUM HAND CHAIN & HAND CHAIN GUARD

- A 23 5/8"
- B 10 5/8"
- \* C 3 7/8"
- \* D 11 1/8"
- \* E 1 3/8"
- F 4 1/2"
- G 8"
- \*\* H 9"
- I 1 1/8"
- J 1 11/16" Tread Width
- K 10" Flange O.D.
- L 8 1/4" Tread O.D.
- M 2 1/2"
- N 1"
- O 3 1/4"
- ~ P 7/8" Rubber Bumper

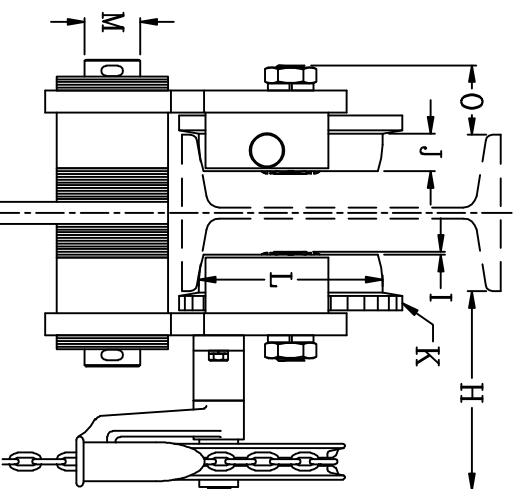
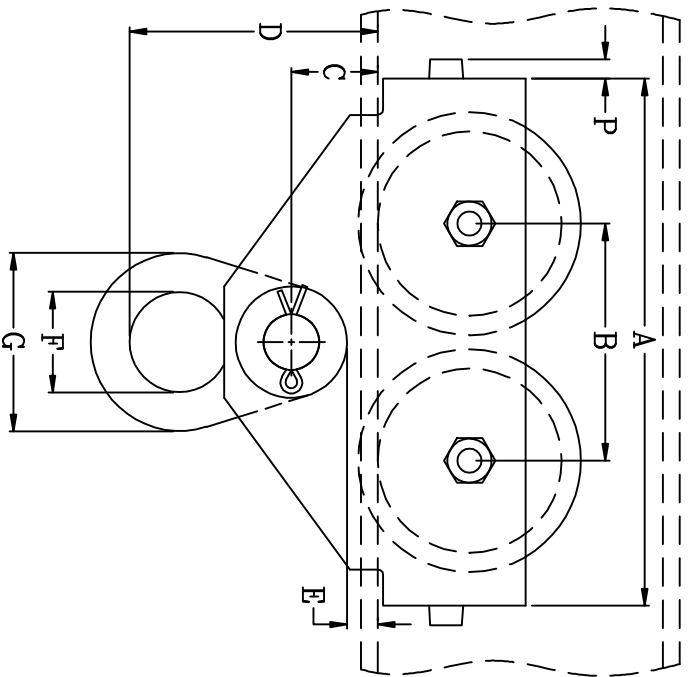

\* To wheel running surface of beam.  
 \*\* "H" applies to geared units only - For plain units "O" dimension is the same for both sides of trolley.  
 ~ "P" applies only to units with removable rubber bumpers  
 THIS UNIT IS ADJUSTABLE FROM 4.62"-8", MINIMUM BEAM HEIGHT: 10"  
 CUSTOMER MUST TAKE INTO CONSIDERATION FLANGE WIDTH AND THICKNESS.

MR.	CK-DATE
REVISIONS	

10 & 12 TON 1641/1642 TROLLEY  
**CHESTER HOIST**  
 LISBON, OHIO

DR. MAM	TR.	CK.	AP.
SCALE NONE		DATE 3/2/09	
REF. DWG. NO. 1600-10			
Dwg. No. C-50050			