

SPARK RES'T. UNIT

- * A 9 15/16"
- B 15 1/8"
- C 12 1/4"
- D 12 1/4"
- E 6 1/2"
- F 10 5/8"
- G 10 5/8"
- H 6 5/8"
- I 6 3/8"
- J 2 7/32"
- L 1 11/32"
- M 6 3/8"
- ** N 1"
- S 8"
- T 1/4"

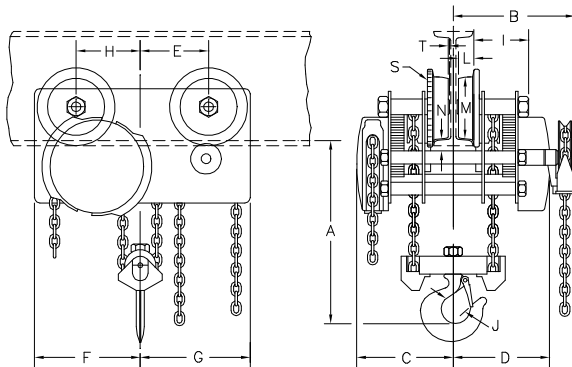

* Applies to geared units only
 ** At closest point of contact
 This unit is beam specific (non-adjustable)
 Dimensions shown are accurate for
 'S' & 'W' beam shapes

Dim. "A" assumes a 1/4" thick beam flange with 1/4" clearance between hook shank and bottom of beam. If your beam flange is thicker, add this difference to the "A" dim.

THIS DRAWING SUPPLIED FOR DIMENSIONAL PURPOSES ONLY
 VISUAL DETAILS MAY VARY SLIGHTLY FROM UNIT SUPPLIED
 HOWEVER DIMENSIONS SHOWN APPLY

HOIST PC#4

		4 TON LOW HEADROOM HOIST	DR.RLB	TR.	CK.	AP.
		CHESTER HOIST	SCALE NONE		DATE 9/11/07	
		LISBON, OHIO	REF. DWG. NO.			
MK.	REVISIONS	CK-DATE	Dwg. No. CN234			