

**SPARK RESISTANT**  
**-BRONZE HOOK**  
**-STAINLESS STEEL CHAIN**

PC# 1 NO. REQ. 1

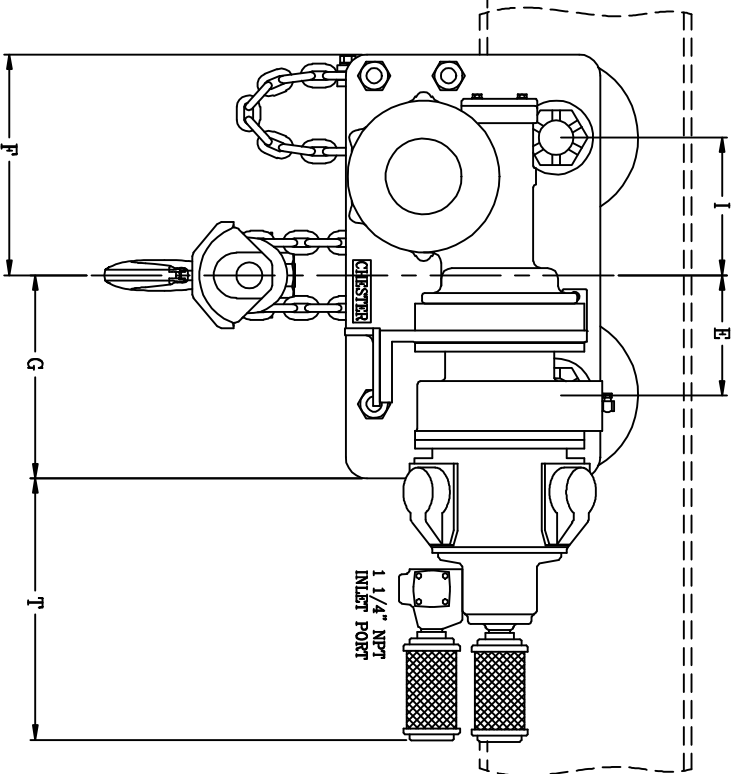
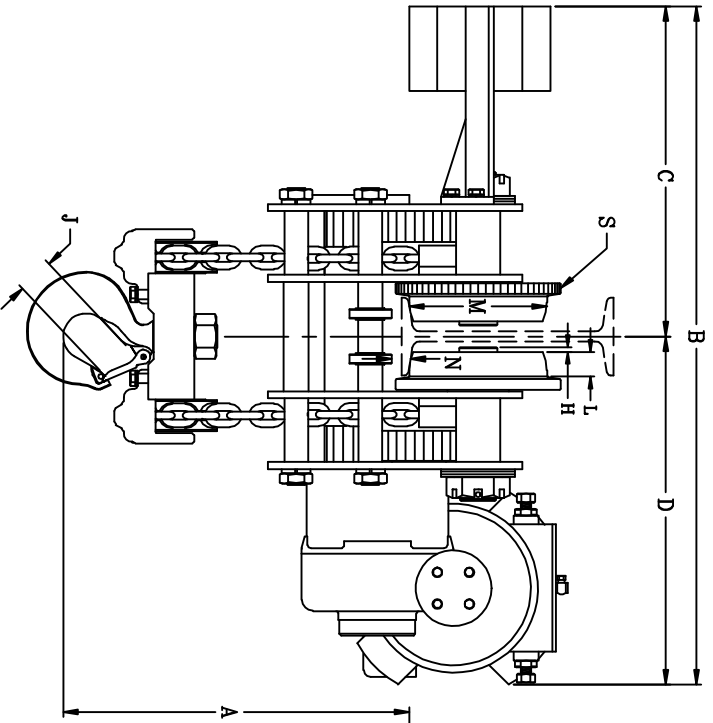

*@A	14 5/8"
B	48 3/16"
C	23 3/8"
D	24 13/16"
E	8 1/2"
F	15 5/8"
G	14 3/8"
H	3/8"
I	9 3/4"
J	3 1/32"
L	1 3/4"
M	9 3/4"
N	1 1/4"
R	xx
S	11 11/16"
T	18 5/8"

\* TO WHEEL RUNNING SURFACE OF BEAM  
 # TO UNDER BEAM ROLLER - (CLOSEST POINT OF CONTACT)  
 FROM THE FACE OF THE WHEEL TO END OF THE AXLE  
 CUSTOMER MUST TAKE INTO CONSIDERATION FLANGE WIDTH AND THICKNESS OF BEAM  
 DIMENSIONS SHOWN ARE CORRECT FOR ANY "S" OR "W" BEAM, PLAIN, HAND GEARED OR MOTORIZED TROLLEY.  
 NOTE: THIS UNIT OPERATES ONLY ON THE BEAM SPECIFIED  
 @ FOR BEAMS WITH FLANGES THICKER THAN 3/4" AT RUNNING SURFACE, "A" WILL INCREASE BY FLANGE THICKNESS LESS 3/4"

8 TON AIR LOW HEADROOM HOIST

CHESTER HOIST

LISBON, OHIO

DR. MAM	TR.	CK.	AP.
---------	-----	-----	-----

SCALE NONE	DATE 8/29/08
------------	--------------

REF. DWG. NO.

Dwg. No. C-49036

REV. NO.	DATE