

CM[®]

Specifications for
Hoists
and **Trolleys**



Items to Consider When Selecting Powered Hoists and Trolleys

- Capacity (lbs., tons, or kg.)
- Lift (ft. or m)
- Lift speed (ft. / min.) (m / min.)
- Lifting medium (chain or wire rope)
- Power (electric, air, etc.)
- Power cord length
- Push button cord length
- Type of suspension
- Type of trolley
(manual, powered, plain, geared)
- Headroom requirements
- Beam size and type
- Trolley speed
- Trolley brake requirements
- Power Supply voltage
- Control voltage
- Single, two speed or variable speed
- Duty cycle requirements
- Special electrification needs
- Abnormal operating conditions
- Chain container

The Following are trademarks of Columbus McKinnon Corporation registered in the U.S. Patent and Trademark Office: **CM, AirStar, Apollo, Lodestar, Load Limiter, Powerstar, RailStar, ShopStar, Valustar.**

The following are trademarks of Columbus McKinnon Corporation: **ShopAir, LodeRail.**

Table of Contents

ELECTRIC CHAIN HOISTS

Lodestar & Classic Lodestar	4-14
Lodestar XL	15-19
Man Guard.....	20-21
ShopStar	22-23
ShopStar VS	24-25
Valustar.....	26-27
Powerstar	28-34

AIR CHAIN HOISTS

Lodestar Air XL.....	35-37
ShopAir.....	38-40
Airstar	41-43
Airstar 6	44-46
TMM - 140 Manipulator.....	47

HAND CHAIN HOISTS

Hurricane 360°	48-49
Cyclone (including Army Type, Low Headroom & Accessories	50-59
Series 622	60-61

LEVER TOOLS

Series 602 & 603 Mini Ratchet	62-63
Bandit	64-65
Tornado 360°	66-69
Series 653.....	70-71
Puller	72
Short Handle Puller	73
Rigger.....	74
Wire Rope Lever Hoist	75
GT Series Grip and Pull.....	76

TROLLEYS

UT (Universal Trolley).....	77
CTP (Adjustable Trolley Clamp).....	78
Series 632 Close Radius	79
Series 84A Heavy Duty.....	80-81
CBT Trolley	82-83
Series 633 Wide Range.....	84
Railstar	85
Tractor Drive	86

ACCESSORIES

Hoist Test Stand	87
Rocket Universal Pendant Control	88

Lodestar electric chain hoist

INTRODUCING THE NEXT GENERATION OF
LODESTAR WITH CAPACITIES OF UP TO 3 TONS.

STANDARD FEATURES

CAPACITIES: 1/8 TO 3 TONS

**FABRIC CHAIN CONTAINER
& RIGID HOOK SUSPENSION**
Standard on every Lodestar

LIFETIME WARRANTY
The industry's best warranty against
manufacturing and material defects.

METRIC RATED

CSA/US
National Recognized
Testing Laboratory (NRTL)

MADE IN THE USA



SPECIFICATIONS

	Capacity (tons)	Product Code		Model	Hoist Lifting Speed (FPM)	Motor HP	Reeving	Weight (lbs.)	
		**Rigid Hook Suspension & Chain Container						115-1-60	230/460 3-60
		115-1-60	230/460 3-60						
Single Speed 10' Lift	1/8	2702NH	2705NH	A	32.0	1/4	1	54	60
	1/8	2712NH	2715NH	AA	60.0	1/2	1	67	64
	1/4	2722NH	2725NH	B	16.0	1/4	1	53	61
	1/4	2732NH	2735NH	C	32.0	1/2	1	61	64
	1/2	2742NH	2745NH	E	8.0	1/4	2	71	69
	1/2	2752NH	2755NH	F	16.0	1/2	1	61	65
	1/2	3512NH	3515NH	J	32.0	1	1	110	110
	1/2	-	3545NH	JJ	64.0	2	1	—	117
	1	2762NH	2765NH	H	8.0	1/2	2	72	73
	1	3522NH	3525NH	L	16.0	1	1	113	110
	1	-	3555NH	LL	32.0	2	1	—	117
	2	3532NH	3535NH	R	8.0	1	2	131	130
	2	-	3565NH	RR	16.0	2	2	—	135
	3	9501NH	9505NH	RT	5.5	1	3	158	158
3	-	9508NH	RRT	11.0	2	3	—	162	
Single Speed 15' Lift	1/8	3101NH	3103NH	A	32.0	1/4	1	59	64
	1/8	3111NH	3113NH	AA	60.0	1/2	1	67	79
	1/4	3121NH	3123NH	B	16.0	1/4	1	61	64
	1/4	3131NH	3133NH	C	32.0	1/2	1	66	75
	1/2	3141NH	3143NH	E	8.0	1/4	2	70	80
	1/2	3151NH	3153NH	F	16.0	1/2	1	67	72
	1/2	4212NH	4214NH	J	32.0	1	1	118	115
	1/2	-	4244NH	JJ	64.0	2	1	—	123
	1	3161NH	3163NH	H	8.0	1/2	2	80	85
	1	4222NH	4224NH	L	16.0	1	1	120	114
	1	-	4254NH	LL	32.0	2	1	—	122
	2	4232NH	4234NH	R	8.0	1	2	140	138
	2	-	4264NH	RR	16.0	2	2	—	144
	3	9502NH	9506NH	RT	5.5	1	3	174	171
3	-	9509NH	RRT	11.0	2	3	—	176	
Single Speed 20' Lift	1/8	3102NH	3104NH	A	32.0	1/4	1	64	68
	1/8	3112NH	3114NH	AA	60.0	1/2	1	72	74
	1/4	3122NH	3124NH	B	16.0	1/4	1	64	72
	1/4	3132NH	3134NH	C	32.0	1/2	1	69	76
	1/2	3142NH	3144NH	E	8.0	1/4	2	80	88
	1/2	3152NH	3154NH	F	16.0	1/2	1	71	76
	1/2	4213NH	4215NH	J	32.0	1	1	124	124
	1/2	-	4245NH	JJ	64.0	2	1	—	128
	1	3162NH	3164NH	H	8.0	1/2	2	86	90
	1	4223NH	4225NH	L	16.0	1	1	124	119
	1	-	4255NH	LL	32.0	2	1	—	127
	2	4233NH	4235NH	R	8.0	1	2	148	148
	2	-	4265NH	RR	16.0	2	2	—	156
	3	9503NH	9507NH	RT	5.5	1	3	187	184
3	-	9510NH	RRT	11.0	2	3	—	194	

Fabric Chain Containers included on all models for up to 20 ft. Lift

*Hoist only without suspension & chain container must be ordered through the configurator.

**Rigid hook suspension & fabric chain container are standard with hoist codes listed above.

When ordering, specify code number(s), model, capacity, beam size, power supply, suspension, lift, extra control cord or power cord, (if required) and type of electrification (if required).

CSA APPROVED†

† Hook Suspension models only.

OPTIONAL FEATURES

DOUBLE DC BRAKE

Two independent acting DC Brakes for redundant braking. Field Installation Kit available.

AC ELECTRIC BRAKE

VARIABLE SPEED DRIVE (VFD) OR TRADITIONAL 2 SPEEDS AVAILABLE

PRIMARY & SECONDARY TRANSFORMER FUSING

ROTATABLE LIMIT SWITCH

Designed for quick reset of limit position

BLACK PHOSPHATE OR STAINLESS STEEL LOAD CHAIN

METAL & STAINLESS STEEL CHAIN CONTAINERS

Lodestar electric chain hoist - Specifications

SPECIFICATIONS

	Capacity (tons)	Product Code		Model	Hoist Lifting Speed (FPM)	Motor HP	Reeving	Weight (lbs.)	
		**Rigid Hook Suspension & Chain Container						230-3-60	460-3-60
		230-3-60	460-3-60						
Two Speed 10' Lift	1/8	2707NH	2708NH	A2	10/32	1/4	1	67	73
	1/8	2717NH	2718NH	AA2	20/60	1/2	1	74	75
	1/4	2727NH	2728NH	B2	5/16	1/4	1	67	73
	1/4	2737NH	2738NH	C2	10/32	1/2	1	73	74
	1/2	2747NH	2748NH	E2	2.5/8	1/4	2	76	82
	1/2	2757NH	2758NH	F2	5/16	1/2	1	74	74
	1/2	3502NH	3503NH	J2	10/32	1	1	116	117
	1/2	3549NH	3550NH	JJ2	21/64	2	1	130	130
	1	2767NH	2768NH	H2	2.5/8	1/2	2	83	84
	1	3504NH	3505NH	L2	5/16	1	1	116	117
	1	3553NH	3554NH	LL2	10/32	2	1	130	131
	2	3506NH	3507NH	R2	2.5/8	1	2	134	135
	2	3561NH	3562NH	RR2	5/16	2	2	149	149
	3	9511NH	9513NH	RT2	1.75/5.5	1	3	161	176
	3	9512NH	9514NH	RRT2	3.5/11	2	3	176	174
Variable Frequency Drive	1/8***	2709NH	2710NH	A	32.0	1/4	1	65	65
	1/4***	2726NH	2729NH	B	16.0	1/4	1	65	65
	1/4***	2734NH	2736NH	C	32.0	1/2	1	65	65
3 - Step Infinitely Variable Control	1/2***	2730NH	2731NH	F	16.0	1/2	1	65	65
	1/2***	3635NH	3636NH	J	32.0	1	1	110	110
	1/2***	3642NH	3643NH	JJ	64.0	2	1	110	110
	1***	3625NH	3626NH	L	16.0	1	1	110	110
	1***	3644NH	3645NH	LL	32.0	2	1	110	110
6 to 1 Speed Ratio	2***	3632NH	3633NH	R	8.0	1	2	110	110
	2***	3646NH	3647NH	RR	16.0	2	2	110	110
10' Lift	3***	9531NH	9534NH	RT	5.5	1	2	110	110
	3***	9539NH	9540NH	RRT	11.0	2	2	110	110

Fabric Chain Containers included on all models for up to 20 ft. Lift

** Rigid hook suspension & fabric chain container are standard with hoist codes listed above.

*** Not CSA Approved.

Control Cord drop is 4 ft. less than Lift.

VFD units are factory set for 3-Step Infinitely Variable Control and include 3-Step Control Station and 115V interface card as standard.

CSA APPROVED†

† Hook Suspension models only.

Less maintenance & easier inspection

- Heavy Duty DC Brake is designed for a long service life. Brake location allows for quick access and easy inspection.
- Lifetime grease-lubricated Gear Box means no oil change out is required. Precision gears provide better wear and longer life.
- Clutch located outside the Gear Box allows for easy access which eliminates the need for complete disassembly and reduces downtime.

Improved serviceability

- Easy access to the Clutch, Motor, Electrical Control Panel and Brake Assembly.

Longer service life

Lifetime grease-lubricated Gear Box and helical gearing ensures efficient operation. Heavy duty rated motors. Hoist workmanship backed by a lifetime warranty.

Quieter operation

80% reduction in sound pressure as compared to the classic Lodestar.

HOIST SUSPENSIONS

	Product Code	Models	Weight (lbs.)
Rigid Hook**	2788NH	A-AA-B-C-F	2
	2789NH	E-H	4
	3651NH	J-L-JJ-LL	4
	3658NH	R-RR	8
	9559NH	RT-RRT	7
Rigid Latchlok Hook	2790NH	A-AA-B-C-F	3
	3652NH	J-L-JJ-LL	5
Swivel Hook	2792NH	A-AA-B-C-F	2
	2793NH	E-H	4
	3661NH	J-L-JJ-LL	4
	3660NH	R-RR	8
	9557NH	RT-RRT	7
Swivel Latchlok Hook	2796NH	A-AA-B-C-F	3
	3662NH	J-L-JJ-LL	5
	3663NH	R-RR	9
Rigid Lug for Low Headroom Trolley	2778NH	A-AA-B-C-F	2
	2779NH	E-H	3
	3677NH	J-L-JJ-LL	4
	3668NH	R-RR	6
	9561NH	RT-RRT	5
Rigid Lug for Motor Driven Trolley	2992NH	A-AA-B-C-F	2
	2993NH	E-H	3
	3679NH	J-L-JJ-LL	4
	3668NH	R-RR	6
	9561NH	RT-RRT	5



Improved load safety

Clutch is located outside the load path which prevents slipping of the load in an overload condition when brake is not powered.

Improved chain life

5 Pocket Lift Wheel provides better chain and lift wheel engagement for smoother lifting and reduced vibration — which equates to less wear and a longer chain life. Zinc plating to protect chain from environmental conditions.

Easy access control panel

With finger-safe wiring and plug and play connectors, the Control Panel allows for quick voltage change, access to terminal strips and simple fuse installation.

Exceeds H4 requirements

Lodestar exceeds H4 requirements, engineered for high duty cycles and the toughest applications.

Eco-friendly

Lifetime grease-lubricated Gear Box means no changing and disposing of hazardous oil. Documented RoHS compliance. Shipped in boxes made of recycled material.

Lodestar electric chain hoist (2-ton, single-reeved)

THE CM® LODESTAR® IS NOW AVAILABLE AS AN ECONOMICAL 2-TON, SINGLE-REEVED UNIT THAT'S IDEAL FOR A VARIETY OF INDUSTRIAL LIFTING APPLICATIONS. AND, BECAUSE IT'S A SINGLE REEVED UNIT, THE DESIGN PREVENTS THE LOWER HOOK BLOCK FROM CAPSIZING AND DAMAGING THE HOIST.

STANDARD FEATURES

LESS MAINTENANCE & EASIER INSPECTION

- Brake location allows for quick access and easy inspection.
- Lifetime grease-lubricated Gear Box means no oil change is required.
- Clutch located outside the Gear Box allows for easy access which eliminates the need for complete disassembly and reduces downtime.

IMPROVED SERVICEABILITY

Easy access to the Clutch, Motor, Electrical Control Panel and Brake Assembly.

LONGER SERVICE LIFE

- Heavy-duty DC brake is designed for a long service life.
- Lifetime grease-lubricated Gear Box and helical gearing ensures better wear and smooth operation.
- Heavy-duty rated motors.

IMPROVED LOAD SAFETY

Clutch is located outside the load path preventing slipping of the load in an overload condition when the brake is not powered.

IMPROVED CHAIN LIFE

5-Pocket Lift Wheel provides better chain and lift wheel engagement for smoother lifting and reduced vibration equating to less wear and a longer chain life. Zinc plating protects chain from environmental conditions.

OPTIONAL FEATURES

DOUBLE DC BRAKE

Two independent acting DC Brakes for redundant braking. Field installation kit available.

VARIABLE SPEED DRIVE (VFD)

PRIMARY & SECONDARY TRANSFORMER FUSING

ROTATABLE LIMIT SWITCH

Designed for quick reset of limit position.

METAL CHAIN CONTAINERS

EASY ACCESS CONTROL PANEL

Finger-safe wiring and plug-and-play connectors on the Control Panel allow for quick voltage change, easy access to terminal strips and simple fuse installation.

ZINC PLATED LOAD CHAIN

Designed and manufactured in the USA by Columbus McKinnon. 10 millimeter, zinc plated Star Grade load chain protects against corrosion.

ADJUSTABLE LIMIT SWITCH

Easy-to-adjust screw limit switch automatically stops the hook at any predetermined point when either lifting or lowering, preventing overtravel.

OVERLOAD PROTECTOR

Helps prevent lifting of dangerous overloads.

METRIC RATED

LIFETIME WARRANTY

The industry's best warranty against manufacturing and material defects.

FABRIC CHAIN CONTAINER

Standard up to 20 ft lift.

RIGID HOOK SUSPENSION



Lodestar electric chain hoist (2-ton, single-reeved) - Specifications

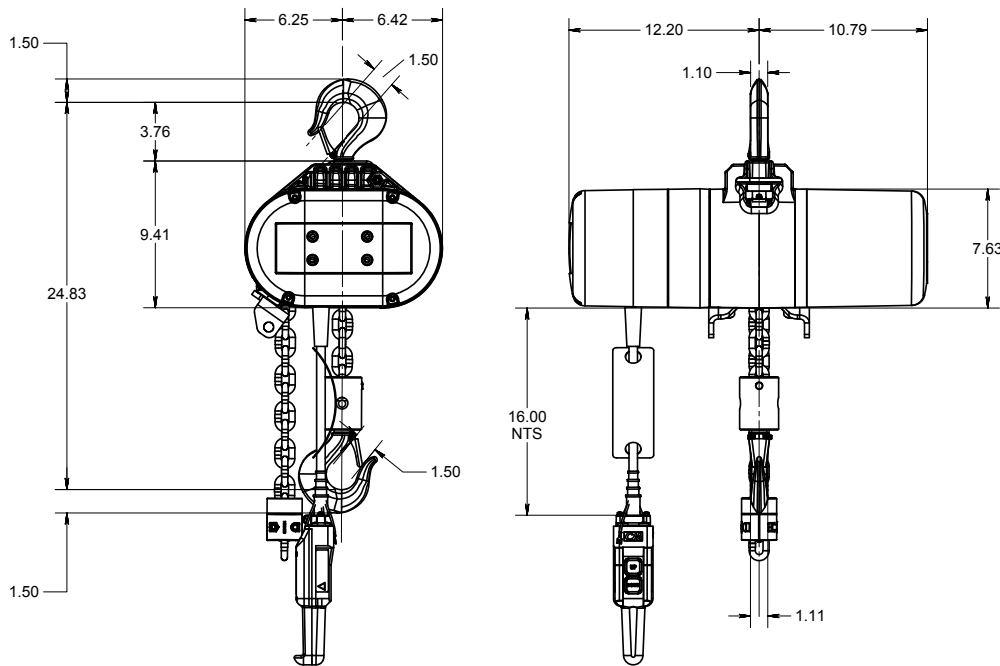

Dimensions (in inches) are RRS model CM Lodestar 2 Ton Single Reeved with Swivel Latch Type Hook Suspension.

For a complete list of dimensions for a specific model type/configuration, visit www.cmworks.com/Library/

SPECIFICATIONS

	Capacity (tons)	Voltage	Product Code**	Model	Hoist Lifting Speed (FPM)	Motor HP	Reeving	Weight (lbs.)
			**Rigid Hook Suspension & Chain Container					
Single Speed Less Chain	2 Ton	230/460-3-60	3565S1LC	RRS	16	2	1	141
Single Speed 10' Lift	2 Ton	230/460-3-60	3565S1	RRS	16	2	1	156
	2 Ton	575-3-60	9280S1	RRS	16	2	1	156
Single Speed 15' Lift	2 Ton	230/460-3-60	4264S1	RRS	16	2	1	164
Single Speed 20' Lift	2 Ton	230/460-3-60	4265S1	RRS	16	2	1	172
Variable Frequency Drive 10' Lift	2 Ton	230-3-60	3646S1	RRS	16	2	1	161
	2 Ton	460-3-60	3647S1	RRS	16	2	1	162

Fabric Chain Containers included on all models for up to 20 ft. Lift

*Hoist only without suspension & chain container must be ordered through the configurator.

**Rigid hook suspension & fabric chain container are standard with hoist codes listed above.

When ordering, specify code number(s), model, capacity, beam size, power supply, suspension, lift, extra control cord or power cord, (if required) and type of electrification (if required).

STAR GRADE LOAD CHAIN, BULK CHAIN

Product Code	Size	Finish	Feet per Drum
85960EN250	10 mm	Zinc Plated	250
85960EN500			500
85960EN1000			1000

CHAIN CONTAINERS

Fabric Chain Containers included on all New Lodestar models up to 20 ft. Lift

Product Code	+ Bucket Length (in.)	Weight (lbs.)	Maximum Length of Lift (ft.)
CANVAS			
10001562	10	4.0	20
10001568	13	4.1	30
10001569	16	4.2	40
10001570	18	4.3	50
10001571	20	4.4	60
METAL			
10001563	10	12.4	30
10001564	15	15.7	55
10001565	20	19.0	80
10001566	25	22.4	105
10001567	30	25.7	130

HOIST SUSPENSIONS

Type	Product Code	Use for Models	Weight (lbs.)
Swivel Hook	10001574	RRS	5.4
	10001573	RRS	5.6
Rigid Hook**	10001573X (cross mount)	RRS	5.6
	10001577	RRS	3.6
Rigid Lug	10001577X (cross mount)	RRS	3.6
	10001575	RRS	5.2
Rigid Latchlok Hook	10001575X (cross mount)	RRS	5.2
	10001576	RRS	5.0
Swivel Latchlok Hook	10001578	RRS	-
Universal Trolley Lug	10001578X (cross mount)	RRS	-

CSA APPROVED

Single speed hook suspended models are CSA Approved as standard. For trolley-mounted models, please contact your CMCO representative.

Classic Lodestar electric chain hoist

The balanced, integrated, proven design of the Lodestar has made it the most popular electric chain hoist in the industry. Lodestar gives you more value for your money including:

- Quick change voltage board-change from low voltage to high voltage by simply re-positioning receptacle
- Up to 3 ton capacities for heavy-duty industrial applications
- Gear train lifetime lubricated with non-oxidizing grease
- Precision machined and hardened lift-wheel with hardened chain guides for precise chain liftwheel fit
- Gearing designed for exceptionally long life and quiet operation
- H4 duty standard
- Rugged control station (NEMA 4X)
- Hoist duty motor, standard Protector overload device and standard adjustable screw type limit switches
- Hardened, forged steel, latch type hooks and Hoistaloy load chain for long, dependable service
- Zinc plated load chain standard
- Easy to install and maintain
- No special tools required to disassemble
- Lifetime warranty
- Each hoist thoroughly inspected and tested to over 125% of rated load prior to shipment
- Meets ASME B30.16
- Metric rated
- Made in U.S.A.



Special applications

- Harsh environment hoists available for severe duty of plating, galvanizing and washdown applications
- Hoists with climbing capability available for temporary rigging or lifting applications — must be used in inverted position only
- Hoists with creep control allow precise positioning through field adjustment within the time delay range of .05 sec. to 3 sec.
- Articulating suspension 3 ton only



Specifications — two speed

Rated capacity* (tons)	Standard lift (ft.)	Lift speed (F.P.M.)	Motor H.P.	Model	Reeving	Product code† less suspension		Approximate shipping weight (lbs.)
						230-3-60	460-3-60	
1/8	10	10/32	1/4	A2	1	2707	2708	70
	10	20/60	1/2	AA2	1	2717	2718	74
1/4	10	5/16	1/4	B2	1	2727	2728	70
	10	10/32	1/2	C2	1	2737	2738	74
1/2	10	2.5/8	1/4	E2	2	2747	2748	79
	10	5/16	1/2	F2	1	2757	2758	74
	10	10/32	1	J2	1	3502	3503	116
	10	21/64	2	JJ2	1	3549	3550	130
1	10	2.5/8	1/2	H2	2	2767	2768	83
	10	5/16	1	L2	1	3504	3505	116
	10	10/32	2	LL2	1	3553	3554	130
2	10	2.5/8	1	R2	2	3506	3507	136
	10	5/16	2	RR2	2	3561	3562	150
3	10	1.75/5.5	1	RT2	3	9511	9513	161
	10	3.5/11	2	RRT2	3	9512	9514	175

†Specify voltage 230 or 460

Classic Lodestar electric chain hoist - Specifications

Specifications — single speed

Rated capacity* (tons)	Standard lift (ft.)	Lift speed (F.P.M.)	Motor H.P.	Model	Reeving	Product code† less suspension		Approximate shipping weight (lbs.)
						115-1-60	230/460-3-60	
1/8	10	32	1/4	A	1	2702	2705	60
	10	60	1/2	AA	1	2712	2715	66
	15	32	1/4	A	1	3101	3103	64
	15	60	1/2	AA	1	3111	3113	70
	20	32	1/4	A	1	3102	3104	68
	20	60	1/2	AA	1	3112	3114	74
1/4	10	16	1/4	B	1	2722	2725	60
	10	32	1/2	C	1	2732	2735	66
	15	16	1/4	B	1	3121	3123	64
	15	32	1/2	C	1	3131	3133	70
	20	16	1/4	B	1	3122	3124	68
	20	32	1/2	C	1	3132	3134	74
1/2	10	8	1/4	E	2	2742	2745	69
	10	16	1/2	F	1	2752	2755	66
	10	32	1	J	1	3512	3515	110
	10	64	2	JJ	1	—	3545	117
	15	8	1/4	E	2	3141	3143	76
	15	16	1/2	F	1	3151	3153	70
	15	32	1	J	1	4212	4214	116
	15	64	2	JJ	1	—	4244	123
	20	8	1/4	E	2	3142	3144	83
	20	16	1/2	F	1	3152	3154	74
	20	32	1	J	1	4213	4215	121
	20	64	2	JJ	1	—	4245	128
1	10	8	1/2	H	2	2762	2765	75
	10	16	1	L	1	3522	3525	110
	10	32	2	LL	1	—	3555	117
	15	8	1/2	H	2	3161	3163	82
	15	16	1	L	1	4222	4224	116
	15	32	2	LL	1	—	4254	123
	20	8	1/2	H	2	3162	3164	89
	20	16	1	L	1	4223	4225	121
	20	32	2	LL	1	—	4255	128
2	10	8	1	R	2	3532	3535	130
	10	16	2	RR	2	—	3565	137
	15	8	1	R	2	4232	4234	140
	15	16	2	RR	2	—	4264	147
	20	8	1	R	2	4233	4235	150
	20	16	2	RR	2	—	4265	157
3	10	5.5	1	RT	3	9501	9505	155
	10	11	2	RRT	3	—	9508	162
	15	5.5	1	RT	3	9502	9506	169
	15	11	2	RRT	3	—	9509	176
	20	5.5	1	RT	3	9503	9507	183
	20	11	2	RRT	3	—	9510	190

†Single speed hoist factory wired 460V, convertible to 230V.

Classic Lodestar with hook suspension

Clearance dimensions (in.)

Dimension	Lodestar models					
	A,B,C,F and AA	E and H	J, L, JJ and LL	R	RR	RT and RRT
A	16 ¹ / ₄	19 ⁵ / ₈	18 ⁹ / ₁₆	24 ¹ / ₈	24 ¹ / ₈	29 ⁹ / ₁₆
B	6 ¹ / ₈	6 ¹ / ₈	7 ⁵ / ₈	7 ⁵ / ₈	7 ⁵ / ₈	7 ⁵ / ₈
C	1 ¹ / ₁₆	7 ⁷ / ₈	7 ⁷ / ₈	1 ¹ / ₈	1 ¹ / ₈	1 ¹ / ₈
D	11	11	9 ¹ / ₂	9 ¹ / ₂	9 ¹ / ₂	9 ¹ / ₂
F	7 ³ / ₄	7 ³ / ₄	10 ¹¹ / ₁₆	10 ¹¹ / ₁₆	10 ¹¹ / ₁₆	10 ¹¹ / ₁₆
H	1	1 ³ / ₁₆	1 ³ / ₁₆	1 ¹ / ₂	1 ¹ / ₂	1 ¹ / ₂
I	4 ¹³ / ₁₆	3 ⁷ / ₈	7 ¹ / ₄	6 ³ / ₁₆	6 ³ / ₁₆	6 ³ / ₁₆
J	3 ¹⁵ / ₁₆	4 ⁷ / ₈	5 ⁷ / ₁₆	6 ¹ / ₂	6 ¹ / ₂	6 ¹ / ₂
L	1 ¹¹ / ₁₆	1 ¹¹ / ₁₆	7 ⁷ / ₁₆	7 ⁷ / ₁₆	7 ⁷ / ₁₆	7 ⁷ / ₁₆
M	1	1 ¹ / ₈	1 ¹ / ₈	1 ⁵ / ₁₆	1 ⁵ / ₁₆	1 ⁵ / ₁₆
P	6 ⁵ / ₈	6 ⁹ / ₁₆	7 ¹³ / ₁₆	7 ¹³ / ₁₆	7 ¹³ / ₁₆	7 ¹³ / ₁₆
R*	9 ⁷ / ₈	12 ⁷ / ₈	12 ⁷ / ₈	18 ⁷ / ₈	18 ⁷ / ₈	24 ⁷ / ₈
AP	9 ¹ / ₄	9 ⁹ / ₁₆	10 ¹¹ / ₁₆	11 ³ / ₁₆	11 ³ / ₁₆	12 ⁹ / ₁₆

* Based on 10 ft. lift and increases proportionately with longer lifts



Suspension specifications

Type	Product code	Models
Swivel hook	2792	A-AA-B-C-F
Swivel hook	2793	E-H
Swivel hook	3661	J-L-JJ-LL
Swivel hook	3660	R-RR
Swivel hook	9557	RT-RRT
Swivel latchlok hook	2796	A-AA-B-C-F
Swivel latchlok hook	3662	J-L-JJ-LL
Swivel latchlok hook	3663	R-RR
Rigid lug for low head trolley	2778	A-AA-B-C-F
Rigid lug for low head trolley	2779	E-H
Rigid lug for low head trolley	3677	J-L-JJ-LL
Rigid lug for low head trolley	3668	R-RR
Rigid lug for low head trolley	9561	RT-RRT
Rigid hook	2788	A-AA-B-C-F
Rigid hook	2789	E-H
Rigid hook	3651	J-L-JJ-LL
Rigid hook	3658	R-RR
Rigid hook	9559	RT-RRT
Rigid latchlok hook	2790	A-AA-B-C-F
Rigid latchlok hook	3652	J-L-JJ-LL

Note: 3 ton lug suspension prevents hoist from rotating but allows hoist to articulate below trolley

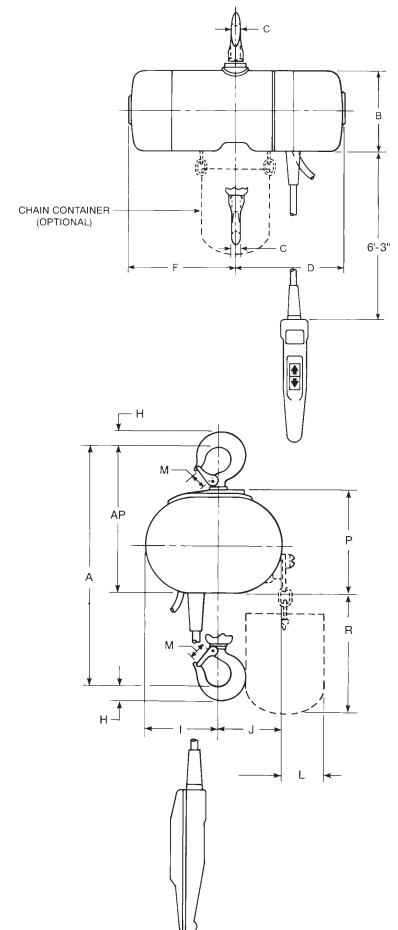

* **WARNING**

Overloading and improper use can result in injury.

To avoid injury:

- Do not exceed working load limit, load rating capacity
- Do not use to lift people or loads over people.
- use only alloy chain for overhead lifting.
- Read and follow all instructions.

Classic Lodestar with Series 635 low headroom trolley

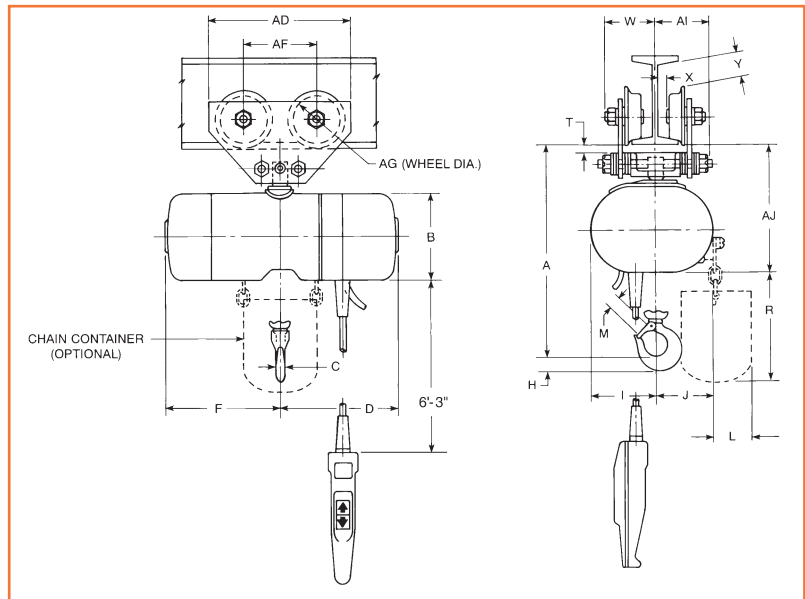

Clearance dimensions (in.)

Dimension	Lodestar models					
	A,B,C,F and AA	E and H	J, L, JJ and LL	R	RR	RT and RRT
A	16 ⁵ / ₁₆	19 ¹ / ₄	18 ¹ / ₄	23 ³ / ₄	23 ³ / ₄	30 ¹ / ₈
B	6 ¹ / ₈	6 ¹ / ₈	7 ⁵ / ₈	7 ⁵ / ₈	7 ⁵ / ₈	7 ⁵ / ₈
C	1 ¹ / ₁₆	7 ⁷ / ₈	7 ⁷ / ₈	1 ¹ / ₈	1 ¹ / ₈	1 ¹ / ₈
D	11	11	9 ¹ / ₂	9 ¹ / ₂	9 ¹ / ₂	9 ¹ / ₂
F	7 ³ / ₄	7 ³ / ₄	10 ¹¹ / ₁₆	10 ¹¹ / ₁₆	10 ¹¹ / ₁₆	10 ¹¹ / ₁₆
H	1	1 ³ / ₁₆	1 ³ / ₁₆	1 ¹ / ₂	1 ¹ / ₂	1 ¹ / ₂
I	4 ¹³ / ₁₆	3 ⁷ / ₈	7 ¹ / ₄	6 ³ / ₁₆	6 ³ / ₁₆	6 ³ / ₁₆
J	3 ¹⁵ / ₁₆	4 ⁷ / ₈	5 ⁷ / ₁₆	6 ¹ / ₂	6 ¹ / ₂	6 ¹ / ₂
L	1 ¹¹ / ₁₆	1 ¹¹ / ₁₆	7 ⁷ / ₁₆	7 ⁷ / ₁₆	7 ⁷ / ₁₆	7 ⁷ / ₁₆
M	1	1 ¹ / ₈	1 ¹ / ₈	1 ⁵ / ₁₆	1 ⁵ / ₁₆	1 ⁵ / ₁₆
R†	9 ⁷ / ₈	12 ⁷ / ₈	12 ⁷ / ₈	18 ⁷ / ₈	18 ⁷ / ₈	24 ⁷ / ₈
T	1 ³ / ₁₆	1 ³ / ₁₆	1 ³ / ₁₆	7 ⁷ / ₈	7 ⁷ / ₈	5 ⁵ / ₁₆
W	3	3	3	3 ⁵ / ₈	3 ⁵ / ₈	4 ¹ / ₈
X	5 ⁵ / ₁₆	5 ⁵ / ₁₆	5 ⁵ / ₁₆	1 ¹ / ₂	1 ¹ / ₂	9 ⁹ / ₁₆
Y	1 ¹ / ₁₆	1 ¹ / ₁₆	1 ¹ / ₁₆	3 ³ / ₁₆	3 ³ / ₁₆	2 ⁵ / ₈
AD	9 ³ / ₄	9 ³ / ₄	9 ³ / ₄	13	13	12 ¹ / ₂
AF	5	5	5	6	6	6
AG	3 ¹ / ₈	3 ¹ / ₈	3 ¹ / ₈	4 ³ / ₄	4 ³ / ₄	4
AI	4 ⁵ / ₈	4 ⁵ / ₈	4 ⁵ / ₈	5	5	5 ¹ / ₂
AJ	9 ³ / ₁₆	9 ³ / ₁₆	10 ³ / ₈	10 ¹³ / ₁₆	10 ¹³ / ₁₆	13 ¹ / ₈

† Based on 10 ft. lift and increases proportionately with longer lifts

Dimensions T, W, X, Y, AI, and AJ are based on minimum beams and will vary proportionately for larger beams. 6'-3" drop of control station is for 10 foot lift hoist and increases proportionately for longer lifts.

Specifications For Series 635 Trolley

Rated capacity* (tons)	Product code	Models	Std. range of adjust. Am. standard S-beams		Tread diameter (in.)	Minimum radius curve (in.)	Approximate shipping weight (lbs.)
			Depth (in.)	Flange width (in.)			
1/8 to 1	3575	A – LL	4 – 15	2 ⁵ / ₈ – 5 ⁵ / ₈	3 ¹ / ₈	24	22
2	3569	R – RR	6 – 18	3 ³ / ₈ – 6	4 ³ / ₄	24	52
3	9576	RT – RRT	8 – 15	4 – 5 ⁵ / ₈	4 ³ / ₄	30	58

Note: Rigid lug suspension required for attaching to hoist. Apply for other than standard beam adjustment. Beam end stop omitted for picture clarity

Classic Lodestar with Series 635 motor driven trolley

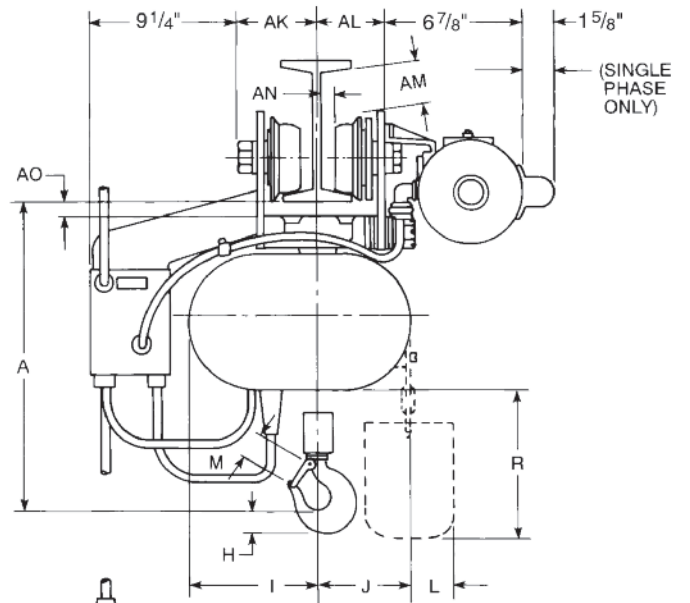
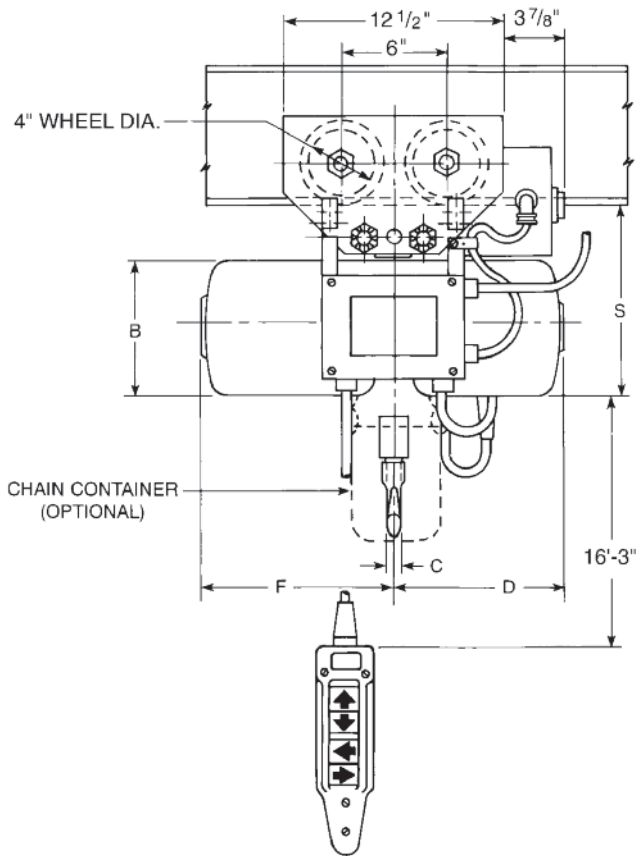

*WARNING
Overloading and improper use can result in injury.
<p>To avoid injury:</p> <ul style="list-style-type: none"> • Do not exceed working load limit, load rating capacity • Do not use to lift people or loads over people. • use only alloy chain for overhead lifting. • Read and follow all instructions.



Classic Lodestar with Series 635 motor driven trolley-Specifications

Clearance dimensions (in.)

Dimension	Lodestar models †					
	A,B,C,F and AA	E and H	J, L, JJ and LL	R	RR	RT and RRT
A	16 ¹³ / ₁₆	19 ³ / ₄	18 ¹ / ₂	23 ³ / ₄	23 ³ / ₄	30 ¹ / ₈
B	6 ¹ / ₈	6 ¹ / ₈	7 ⁵ / ₈	7 ⁵ / ₈	7 ⁵ / ₈	7 ⁵ / ₈
C	1 ¹ / ₁₆	⁷ / ₈	⁷ / ₈	1 ¹ / ₈	1 ¹ / ₈	1 ¹ / ₈
D	11	11	9 ¹ / ₂	9 ¹ / ₂	9 ¹ / ₂	9 ¹ / ₂
F	7 ³ / ₄	7 ³ / ₄	10 ¹¹ / ₁₆	10 ¹¹ / ₁₆	10 ¹¹ / ₁₆	10 ¹¹ / ₁₆
H	1	1 ³ / ₁₆	1 ³ / ₁₆	1 ¹ / ₂	1 ¹ / ₂	1 ¹ / ₂
I	4 ¹³ / ₁₆	3 ⁷ / ₈	7 ¹ / ₄	6 ³ / ₁₆	6 ³ / ₁₆	6 ³ / ₁₆
J	3 ¹⁵ / ₁₆	4 ⁷ / ₈	5 ⁷ / ₁₆	6 ¹ / ₂	6 ¹ / ₂	6 ¹ / ₂
L	1 ¹¹ / ₁₆	1 ¹¹ / ₁₆	⁷ / ₁₆	⁷ / ₁₆	⁷ / ₁₆	⁷ / ₁₆
M	1	1 ¹ / ₈	1 ¹ / ₈	1 ⁵ / ₁₆	1 ⁵ / ₁₆	1 ⁵ / ₁₆
R**	9 ⁷ / ₈	12 ⁷ / ₈	12 ⁷ / ₈	18 ⁷ / ₈	18 ⁷ / ₈	24 ⁷ / ₈
S	9 ¹¹ / ₁₆	9 ¹¹ / ₁₆	10 ⁵ / ₈	10 ¹³ / ₁₆	10 ¹³ / ₁₆	13 ¹ / ₈
AK	3 ³ / ₄	3 ³ / ₄	3 ³ / ₄	3 ³ / ₄	3 ³ / ₄	4 ¹ / ₄
AL	3 ¹ / ₄	3 ¹ / ₄	3 ¹ / ₄	3 ¹ / ₄	3 ¹ / ₄	3 ³ / ₄
AM	⁵ / ₈	⁵ / ₈	⁵ / ₈	⁵ / ₈	⁵ / ₈	2 ⁵ / ₈
AN	⁵ / ₁₆	⁵ / ₁₆	⁵ / ₁₆	⁵ / ₁₆	⁵ / ₁₆	⁹ / ₁₆
AO	⁷ / ₈	⁷ / ₈	⁷ / ₈	⁷ / ₈	⁷ / ₈	1

** Based on 10 ft. lift and increases proportionately with longer lifts

Dimensions S, AK, AL, AM, and AO are based on minimum beams and will vary proportionately for larger beams. 16'-3" drop of control station is for 20 foot lift hoist.

† Note: Rigid lug suspension required for attaching to hoist.

Suspension specifications

Type	Product code	Models
Rigid lug for motor driven trolley	2992	A-AA-B-C-F
Rigid lug for motor driven trolley	2993	E-H
Rigid lug for motor driven trolley	3679	J-L-JJ-LL
Rigid lug for motor driven trolley	3668	R-RR
Rigid lug for motor driven trolley	9561	RT-RRT

Note: Beam end stop omitted for picture clarity

Specifications — motor driven trolley

Rated capacity* (tons)	Product code	For use with model	Power supply	Standard travel speed (F.P.M.)	Motor H.P.	Std. range of adj. Am. std. S-beams		Minimum radius curve (in.)	Approx. shipping weight (lbs.)
						Depth (in.)	Flange width (in.)		
1/8 - 2	3670	A-RR	115-1-60	75	1/4	6 - 15	3 ³ / ₈ - 5 ⁵ / ₈	30	118
1/8 - 2	3671	A-RR	230-3-60	75	1/4	6 - 15	3 ³ / ₈ - 5 ⁵ / ₈	30	118
1/8 - 2	3672	A-RR	460-3-60	75	1/4	6 - 15	3 ³ / ₈ - 5 ⁵ / ₈	30	118
3	9577	RT-RRT	115-1-60	75	1/4	8 - 15	4 - 5 ⁵ / ₈	30	120
3	9578	RT-RRT	230-3-60	75	1/4	8 - 15	4 - 5 ⁵ / ₈	30	120
3	9579	RT-RRT	460-3-60	75	1/4	8 - 15	4 - 5 ⁵ / ₈	30	120
1/8 - 2	9315	A-RR	115-1-60	30	1/4	6 - 15	3 ³ / ₈ - 5 ⁵ / ₈	30	113
1/8 - 2	9316	A-RR	230-3-60	30	1/4	6 - 15	3 ³ / ₈ - 5 ⁵ / ₈	30	113
1/8 - 2	9317	A-RR	460-3-60	30	1/4	6 - 15	3 ³ / ₈ - 5 ⁵ / ₈	30	113
3	9318	RT-RRT	115-1-60	30	1/4	8 - 15	4 - 5 ⁵ / ₈	30	120
3	9319	RT-RRT	230-3-60	30	1/4	8 - 15	4 - 5 ⁵ / ₈	30	120
3	9320	RT-RRT	460-3-60	30	1/4	8 - 15	4 - 5 ⁵ / ₈	30	120

Can be modified to fit larger beams.
Flat tread wheel available.

Beam size and voltage required for ordering.

Apply for other than standard travel speeds.



Classic Lodestar chain container

Metal chain containers (complete)

Made in U.S.A.

Maximum length of lift (ft.)

Product code	†Bucket length (in)	Bucket diameter (in)	Approx. shipping wgt.(lbs.)	Models A,AA,B C&F	Models E&H	Models J,JJ,L&LL	Models R & RR	Models RT & RRT
2450	8	5	4	10	-	-	-	-
2451	11	5	5	20	10	10	-	-
2452	14	5	5	30	15	15	-	-
2453	17	5	6	40	20	20	10	-
2454	20	5	7	50	25	25	-	-
2455	23	5	7	60	30	30	15	10
2456	31	5	9	90	45	40	20	-
2457	36	5	10	100	50	60	30	20
2458	48	5	13	140	*70	90	45	30
2461	10	10	13	44	22	20	14	9
2463	15	10	15	104	52	66	33	2210
2464	20	10	17	166	83	106	53	35
2465	25	10	20	230	115	144	72	48
2466	30	10	23	290	145	150	90	60

For lifts greater than listed (special)...apply.

† Advise if bucket length causes headroom problems, larger diameter shorter length buckets available.

* E & H limit switch maximum is 60 ft.

When ordering, specify code number(s), model, capacity, beam size, power supply, suspension, lift, extra control cord or power cord (if required) and type of electrification (if required).

- Convenient for slack chain storage
- Simple one pin attachment for easy installation
- Security cable included
- Available for every Lodestar and Valustar model
- Made in U.S.A.

Fabric chain bag

CM's chain bags offer an alternative to the standard metal chain container for use with Lodestar or Valustar electric chain hoists. Chain bags are made from an open weave vinyl coated polyester designed especially for extended outdoor life. Not recommended for applications over 300°F, in extremely caustic environments or for chain weight exceeding 300 lbs. Features include:

- Flexible and lightweight material
- Dampens noise
- Will not hold water
- Excellent resistance to ultraviolet rays, mildew stains, rot and weather
- Moisture resistant - quick drying
- High tensile and tear strength
- Abrasion resistant
- No shrinkage
- Bags and brackets are suitable for chain weights up to 300 pounds
- Made in U.S.A.



Specifications

Maximum length of lift (ft.)

Product code	Models A-AA-B-C-F WB-WF	Models E-H WH-WE	Models J,JJ,L,LL WL-WJ	Models R,RR WR	Models RT,RRT	Bag size (in.)	Bag height (in.)	Approx. weight (lbs.)
2470	20	10	-	-	-	7 1/2 x 7 1/2	7	3
2471	40	20	-	-	-	7 1/2 x 7 1/2	10	3
2472	60	30	-	-	-	7 1/2 x 7 1/2	13	3
2473	90	45	-	-	-	7 1/2 x 7 1/2	16	4
2474	100	60	-	-	-	7 1/2 x 7 1/2	18	4
2475	140	90	-	-	-	7 1/2 x 7 1/2	20	4
2476	-	-	10	-	-	7 1/2 x 7 1/2	7	3
2477	-	-	20	10	-	7 1/2 x 7 1/2	10	3
2478	-	-	30	15	10	7 1/2 x 7 1/2	13	3
2479	-	-	45	20	-	7 1/2 x 7 1/2	16	4
2480	-	-	60	30	20	7 1/2 x 7 1/2	18	4
2481	-	-	90	45	30	7 1/2 x 7 1/2	20	4

Lodestar XL electric chain hoist

Columbus McKinnon offers the Lodestar XL electric chain hoists for lifting applications from 2 to 7½ tons. The heavy-duty hoist features faster speeds, less reeving, and higher capacities than traditional chain hoists. Workers in automotive plants, heavy equipment manufacturing, paper mills, and related rugged work environments will experience the same dependability and versatility that they have relied on for many years.

The NEW features of the Lodestar XL Electric Chain Hoist include:

- Lifting capacities up to 7½ tons
- Increased lifting speeds throughout the line
- Double reeved units with 3-5 ton lifting capacities
- Maximum lifting speed of 30 feet per minute



SEE PAGE 88 FOR MORE INFO

A glimpse of the many features of the Lodestar XL that have honed its reputation for durability and long life:

- Heavy-duty, multiple disc braking system
- Forged ten-pocket oblique-lay liftwheel for smooth chain operation, constant chain speed, and reduced chain wear
- Gearing operated in oil bath for increased lifting life and quiet operation
- Rated H-4, heavy-duty
- Standard overload protector
- Adjustable screw-type limit switches
- Thermally protected motor
- Factory tested at 125% of rated capacity
- Made in U.S.A.
- Lifetime warranty



230/460-3-60

575-3-60

Capacity (tons)	Reeving	Speed (fpm)	230/460-3-60				575-3-60			
			Hook	Plain Trolley	Geared Trolley	Motor Driven Trolley	Hook	Plain Trolley	Geared Trolley	Motor Driven Trolley
2	1	18	5201H	5201P	5201G	5201M	5231H	5231P	5231G	5231M
2	1	24	5204H	5204P	5204G	5204M	5232H	5232P	5232G	5232M
2	1	30	5265H	5265P	5265G	5265M	5266H	5266P	5266G	5266M
3	2	9	5209H	5209P	5209G	5209M	5233H	5233P	5233G	5233M
3	2	12	5212H	5212P	5212G	5212M	5234H	5234P	5234G	5234M
3	2	15	5267H	5267P	5267G	5267M	5268H	5268P	5268G	5268M
4	2	9	5215H	5215P	5215G	5215M	5235H	5235P	5235G	5235M
4	2	12	5218H	5218P	5218G	5218M	5236H	5236P	5236G	5236M
4	2	15	5269H	5269P	5269G	5269M	5278H	5278P	5278G	5278M
5	3	6	5221H	5221P	5221G	5221M	5237H	5237P	5237G	5237M
5	3	8	5224H	5224P	5224G	5224M	5238H	5238P	5238G	5238M
5	2	9	5279H	5279P	5279G	5279M	5280H	5280P	5280G	5280M
5	2	12	5283H	5283P	5283G	5283M	5284H	5284P	5284G	5284M
5	2	15	5285H	5285P	5285G	5285M	5286H	5286P	5286G	5286M
6	3	6	5227H	5227P	5227G	5227M	5239H	5239P	5239G	5239M
6	3	8	5230H	5230P	5230G	5230M	5240H	5240P	5240G	5240M
6	3	10	5287H	5287P	5287G	5287M	5288H	5288P	5288G	5288M
7½	3	6	—	5289P	5289G	5289M	—	5290P	5290G	5290M
7½	3	10	—	5291P	5291G	5291M	—	5292P	5292G	5292M

3.5 H.P. XL Models (unshaded) – Available in single speed, 3:1; two speed, variable speed

5.5 H.P. XL Models (shaded) – Available in single speed, variable speed

Lodestar XL with hook suspension

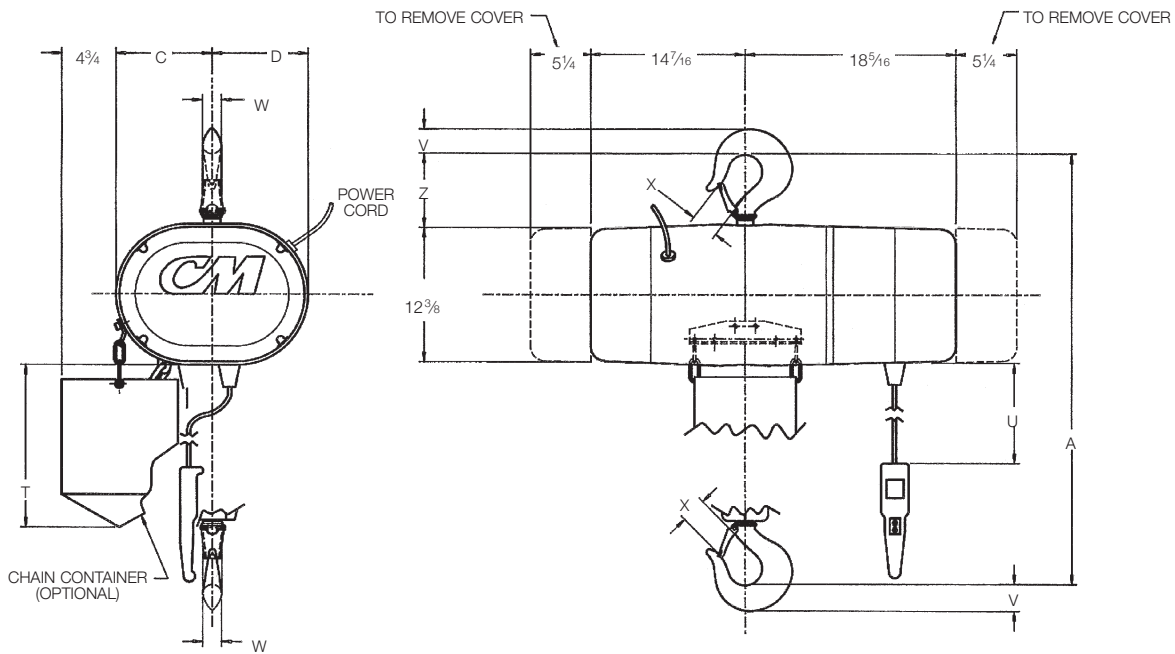

Clearance dimensions (in.)

Dimensions	Single Reeved 2 ton capacity	Double Reeved 3-5 ton capacity	Triple Reeved 5-6 ton capacity
A	25	35 ⁵ / ₁₆	36 ³ / ₁₆
C	8 ⁷ / ₁₆	11 ³ / ₈	11 ³ / ₈
D	8 ¹ / ₈	5 ¹ / ₂	5 ¹ / ₂
T (based on 10 ft. lift)	14 ³ / ₁₆	14 ³ / ₁₆	14 ³ / ₁₆
U (based on 10 ft. lift)	6'- 3"	6'- 3"	6'- 3"
V	1 ¹ / ₂	2 ¹ / ₄	2 ¹ / ₄
W	1 ¹ / ₈	1 ⁵ / ₈	1 ⁵ / ₈
X	1 ⁵ / ₁₆	2 ¹ / ₁₆	2 ¹ / ₁₆
Z	4 ¹ / ₈	5 ¹ / ₂	5 ¹ / ₂



*WARNING

Overloading and improper use can result in injury.

To avoid injury:

- Do not exceed working load limit, load rating capacity
- Do not use to lift people or loads over people.
- use only alloy chain for overhead lifting.
- Read and follow all instructions.

Lodestar XL with plain trolley and geared Trolley

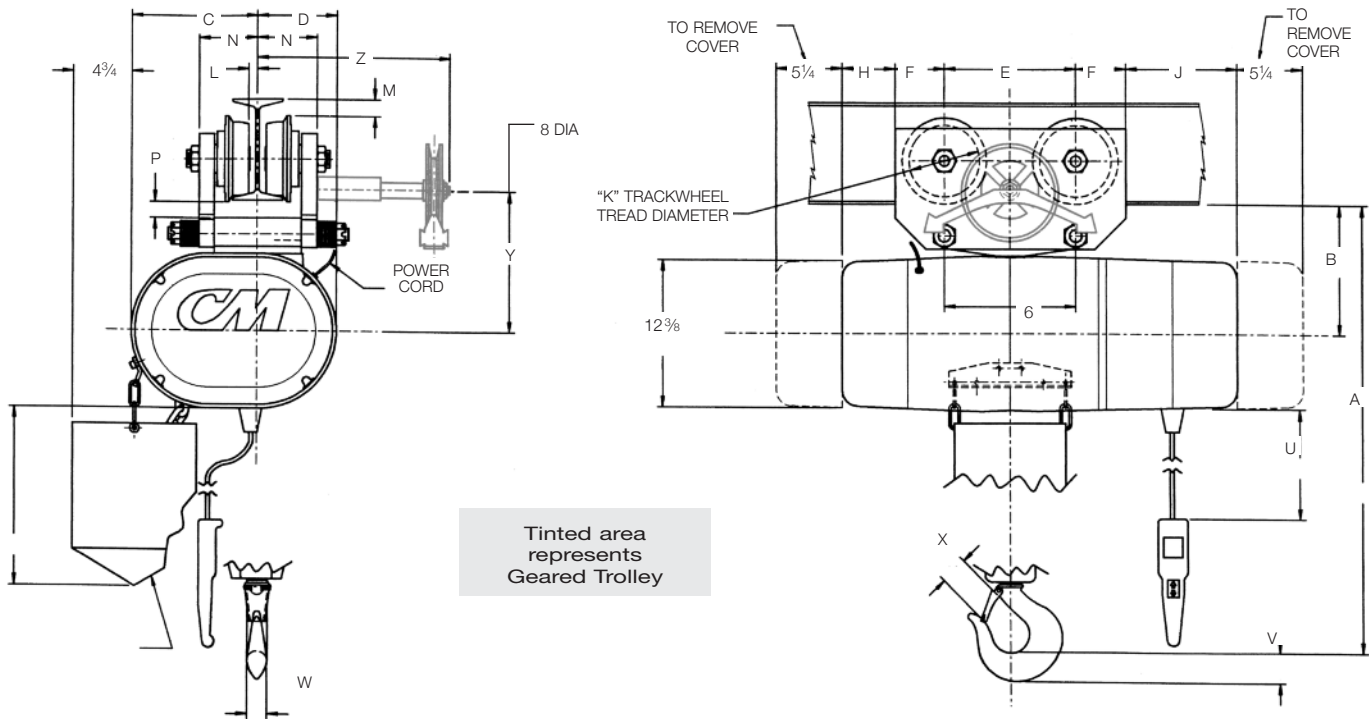

Geared Trolley



Clearance dimensions (in.)**

Dimensions	Single Reeved 2 ton capacity	Double Reeved		Triple Reeved 5-7½ ton capacity
		3 ton capacity	4 & 5 ton capacity	
A	28 ¹¹ / ₁₆	33½	33¾	34 ⁵ / ₈
B	9¾	10 ⁷ / ₁₆	10 ¹¹ / ₁₆	10 ¹¹ / ₁₆
C	8 ⁷ / ₁₆	11 ³ / ₈	11 ³ / ₈	11 ³ / ₈
D	8 ³ / ₈	5½	5½	5½
E	9½	9 ¹ / ₈	12	12
F	3½	3¼	4 ¹³ / ₁₆	4 ¹³ / ₁₆
H	5¼	5 ¹¹ / ₁₆	2 ¹¹ / ₁₆	2 ¹¹ / ₁₆
J	10 ⁷ / ₁₆	10½	7½	7½
K	4 ¹¹ / ₁₆	4	6½	6½
L	½	5/8	5/8	5/8
M	½	2 ¹¹ / ₁₆	0	0
N	5	3 ⁵ / ₈	3 ⁷ / ₈	3 ⁷ / ₈
P	1¼	¾	7/16	7/16
T (based on 10 ft. lift)	14 ³ / ₁₆	14 ³ / ₁₆	14 ³ / ₁₆	14 ³ / ₁₆
U (based on 10 ft. lift)	6'- 3"	6'- 3"	6'- 3"	6'- 3"
V	1½	2¼	2¼	2¼
W	1 ¹ / ₈	1 ⁵ / ₈	1 ⁵ / ₈	1 ⁵ / ₈
X	1 ⁵ / ₁₆	2 ¹ / ₁₆	2 ¹ / ₁₆	2 ¹ / ₁₆
Y*	11 ⁵ / ₁₆	12 ⁷ / ₈	11 ¹ / ₈	11 ¹ / ₈
Z*	—	19 ¹ / ₈	19 ¹ / ₈	19 ¹ / ₈
Minimum Radius Curve (ft.)	4	4	6	6
Standard Beam Flange Adj. Range (in.)	3.33-5.55	4.00-6.25	4.00-6.25	4.00-6.25

*Geared Trolley Dimensions Only

**Dimensions listed are for minimum size "S" beam.

Lodestar XL with motor driven trolley (2 ton)

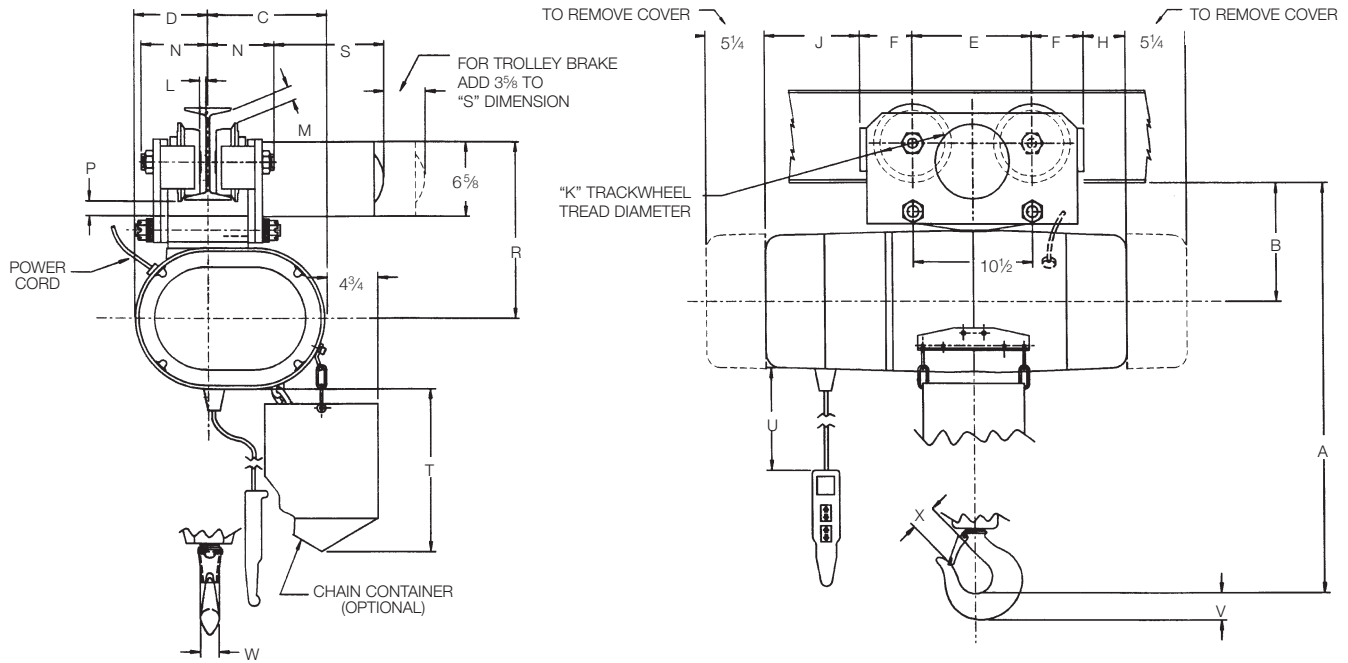

Clearance dimensions (in.)**

Dimensions	Single Reeved 2 ton capacity
A	28 ¹¹ / ₁₆
B	9 ³ / ₄
C	8 ⁷ / ₁₆
D	8 ¹ / ₈
E	9 ¹ / ₂
F	3 ¹ / ₂
H	5 ¹ / ₄
J	10 ¹ / ₁₆
K	4 ¹¹ / ₁₆
L	1/2
M	1/2
N	5
P	1 ¹ / ₄
R	14 ⁵ / ₈
S	12 ⁷ / ₁₆
T (based on 10 ft. lift)	14 ³ / ₁₆
U (based on 10 ft. lift)	6' - 3"
V	1 ¹ / ₂
W	1 ¹ / ₈
X	1 ⁵ / ₁₆
Minimum Radius Curve (ft.)	4
Standard Beam Flange Adj. Range (in.)	3.33-5.55
Trolley Speed (ft./min) Standard Single Speed	65 or 100

**Dimensions listed are for minimum size "S" beam.



*WARNING

Overloading and improper use can result in injury.

To avoid injury:

- Do not exceed working load limit, load rating capacity
- Do not use to lift people or loads over people.
- use only alloy chain for overhead lifting.
- Read and follow all instructions.

Lodestar XL with motor driven trolley (3-7½ ton)

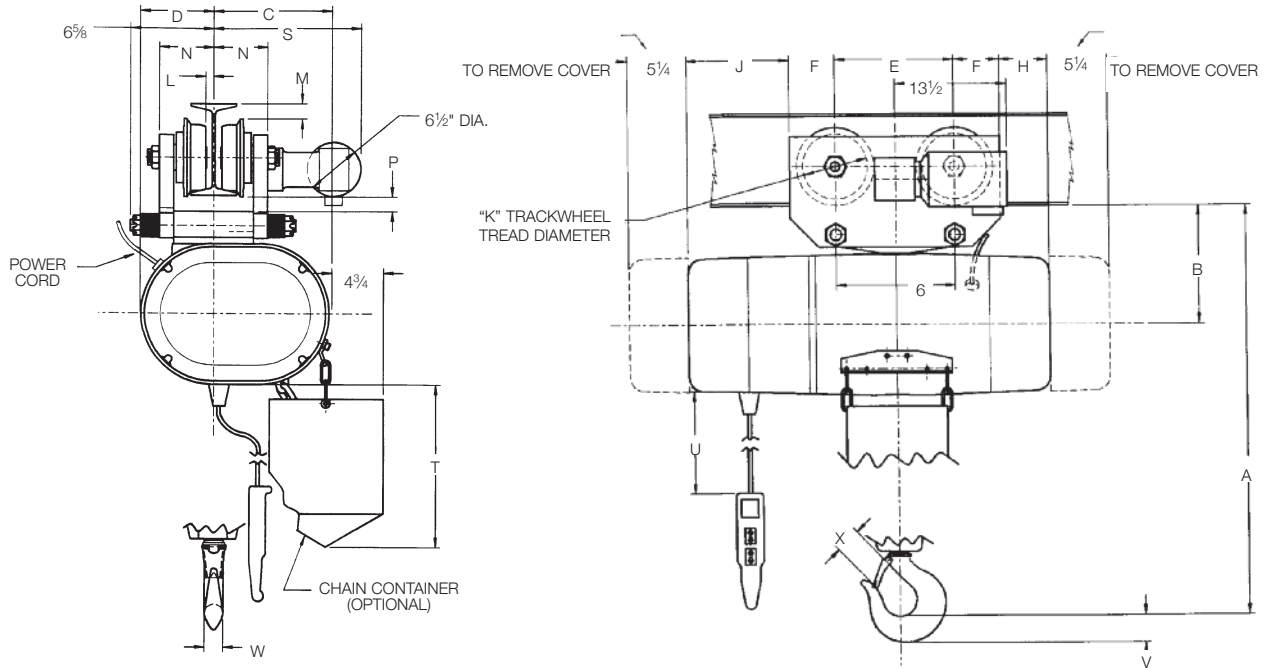

Clearance dimensions (in.)**

Dimensions	Double Reeved		
	3 ton capacity	4 & 5 ton capacity	Triple Reeved 5-7½ ton capacity
A	33½	33¾	34⅝
B	10⅞	10⅞	10⅞
C	11⅞	11⅞	11⅞
D	5½	5½	5½
E	9⅞	12	12
F	3¼	4⅞	4⅞
H	5⅞	2⅞	2⅞
J	10½	7½	7½
K	4	6½	6½
L	⅝	⅝	⅝
M	2⅞	0	0
N	3⅝	3⅞	3⅞
P	⅜	⅞	⅞
S	11⅞	13⅞	13⅞
T (based on 10 ft. lift)	14⅞	14⅞	14⅞
U (based on 10 ft. lift)	6'- 3"	6'- 3"	6'- 3"
V	2¼	2¼	2¼
W	1⅝	1⅝	1⅝
X	2⅞	2⅞	2⅞
Minimum Radius Curve (ft.)	4	6	6
Standard Beam Flange Adj. Range (in.)	4.00-6.25	4.00-6.25	4.00-6.25
Trolley Speed (ft./min)			
Standard Single Speed	50	50	50

**Dimensions listed are for minimum size "S" beam.



Man Guard electric chain hoist

INTRODUCING THE CM MAN GUARD WITH CAPACITIES OF UP TO 3 TONS.

Columbus McKinnon Corporation, an industry leader in quality lifting and positioning equipment for hoist operators around the globe, presents CM Man Guard.

CM Man Guard electric chain hoist stays true to its name by providing operator safety through superior overload protection. The Man Guard hoist's overload clutch prevents lifting loads beyond capacity which may result in serious injury to the operator, or catastrophic damage to the hoist, load and supporting structure.

Made in the USA, Man Guard is designed for a long and dependable service life for heavy duty applications. Additionally, with its environmentally friendly design, easy access to key components, less maintenance, and enhanced safety feature, the Man Guard is the right choice for your lifting needs.

CM Man Guard is available as an individual unit or as an integral component of a complete lifting system.



Capacities: 1/4 to 3 Tons

Standard Lift: 10 feet
Additional lifts available

Lifting Speed: 5 to 32 FPM

Hook Suspension

AC Power Supply

115/230 1-60 HZ; 230/460 3-60
reconnectable voltage

Built-In Compliance

with ASME/ANSI B30.16, ASME
HST-1 and NEC electrical codes

Made in the U.S.A.

OVERLOAD PROTECTION

The CM Man Guard overload clutch prevents lifting beyond load capacity, which may damage the hoist or supporting structure or cause injury to the operator.

READY FOR HEAVY DUTY APPLICATIONS

H4 duty motor classification rated for heavy duty use.

LONGER SERVICE LIFE

- Class F insulation and thermal switch in motor winding reduces motor overheating and increase life.
- Helical Gears are oil bath lubricated which provides better wear and extends gear life while reducing noise.
- Powder coat painted housing and corrosion resistance zinc plated chain provides superior protection against the elements.
- Hard-wired power and pendant cords reduces risk of corrosion and loose connections.

IMPROVED SERVICEABILITY

- Open design allows quick access to AC Brake's one step adjustment.
- Easy access to Control Panel and simple wiring change to switch voltages from 115 to 230V for single phase applications.

SUPERIOR LOAD CONTROL

Optional Variable Frequency Drive (VFD) with 3 Step infinitely variable pendant allows operator to adjust lifting speeds without interruption. Many competitors only offer a 2 Step pendant requiring service interruption to change lift speeds.

ECO-FRIENDLY ENERGY SAVER

Efficiently designed gear train allows a smaller horsepower motor to operate at the same speeds and duty as our competition and reduces energy consumption. Shipped in boxes made of recycled material.

LIFETIME WARRANTY

HOISTS SHIP IN 3 DAYS OR LESS – GUARANTEED

Select models are eligible for our In-Stock Guarantee.



Man Guard electric chain hoist - Specifications

VFD OPTION

- Variable speed control with single speed motor. VFD located completely under the cover.
- 10:1 speed ratio permits precise positioning for load spotting.
- 3-step infinitely variable push-button control offers acceleration and deceleration for full load control.
- Minimizes high-starting current on motor which helps keep it cool extending life of motor, and increases motor run-time and starts/stops over standard contactor control.
- Electronic reversing, multispeed operation (up to 3 steps) eliminates conventional magnetic contactors which are wearable components.
- Fault recorder helps troubleshoot various problems such as power related issues.
- 3 programmable outputs.
- Available Voltages: 380-460/3/60 and 208-230/3/60.

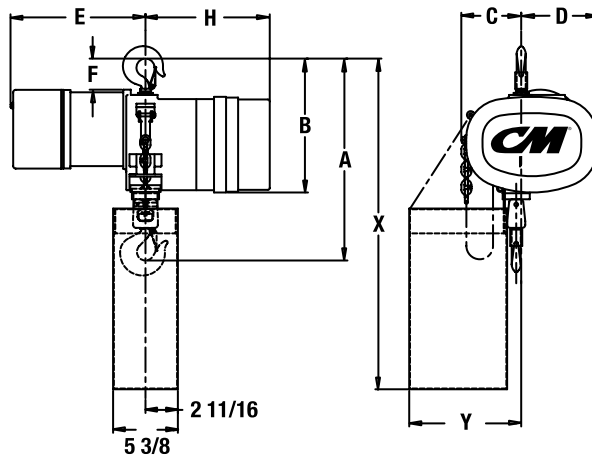

	Capacity	Model Number	Lift Speed	Motor	Parts of Chain	Net Weight	A	B	C	D	E* Max.	F	G	H	X**	Y
SINGLE SPEED HOOK MOUNTED HOISTS	1/4	MG2516	16	1/4	1	77	16-3/4	11-1/8	5	6-5/16	14-1/4	2-9/16	15/16	10-5/16	21-5/8	9-1/2
		MG2532	32	1/2		80								10-5/16		
	1/2	MG5016	16	1/2	1	80	16-3/4	11-1/8	5	6-5/16	14-1/4	2-9/16	15/16	10-5/16	21-5/8	9-1/2
		MG5032	32	1		81								10-5/16		
	1	MG0116	16	1	1	89	17-1/2	11-7/16	5-1/8	6-5/16	14-1/4	2-15/16	1-1/8	10-5/16	21-5/8	9-1/2
		MG0132	32	2-1/2		95								11-5/16		
	2	MG0208	8	1	2	111	23	13-1/8	6-3/8	5-1/16	14-1/4	4-9/16	1-1/16	10-5/16	24-3/4	10-3/4
		MG0216	16	2-1/2		112								11-5/16		
	3	MG0305	5	1	3	136	25-7/8	14-3/8	7-7/8	7-1/8	14-1/4	5-7/8	2	10-5/16	30	12-1/4
		MG0310	10	2-1/2		146								11-5/16		
VFD HOOK MOUNTED HOISTS	1/4	MG2516V	16	1/4	1	77	16-3/4	11-1/8	5	6-5/16	14-1/4	2-9/16	15/16	13-7/16	21-5/8	9-1/2
		MG2532V	32	1/2		80								13-7/16		
	1/2	MG5016V	16	1/2	1	80	16-3/4	11-1/8	5	6-5/16	14-1/4	2-9/16	15/16	13-7/16	21-5/8	9-1/2
		MG5032V	32	1		81								13-7/16		
	1	MG0116V	16	1	1	89	17-1/2	11-7/16	5-1/8	6-5/16	14-1/4	2-15/16	1-1/8	13-7/16	21-5/8	9-1/2
		MG0132V	32	2-1/2		95								13-7/16		
	2	MG0216V	16	2-1/2	2	112	23	13-1/8	6-3/8	5-1/16	14-1/4	4-9/16	1-1/16	13-7/16	24-3/4	10-3/4
		MG0310V	10	2-1/2		146								13-7/16		

* Maximum length for 3 phase model hoists. Consult factory for exact dimensions.

** Dimensions based on lifts through 10 ft. (all capacities) and increases proportionally with longer lifts.



ShopStar electric chain hoist

The ShopStar electric chain hoist features rugged construction and high H4 duty cycle. It keeps lifting and lifting, up to 1,000 pounds and 300 motor starts per hour. Additional features and benefits include:

- H4 duty cycle (300 motor starts/hour)
- Easy installation and maintenance
- Standard protector overload device
- 10 pocket oblique lay liftwheel provides longer chain wear
- Epoxy powder coat finish
- 6½ ft. power cord with molded 3 prong plug on 115 volt units
- NEMA 4 industrial rated control station
- Optional impact-resistant chain container available
- Gear train lifetime lubricated with non-oxidizing grease
- CM Hoist Alloy Load Chain (zinc plated optional)
- Thermally protected hoist duty motor
- Dual braking system — D.C. plus regenerative
- Rugged cast aluminum alloy hoist frame
- Meets ASME B30.16
- Small, compact design for commercial & industrial applications
- Rigid hook suspension prevents tangling of power cord
- Hardened forged steel latch style lower hook rotates 360°
- Totally enclosed non-ventilated hoist frame protects motor from environmental contamination
- True vertical lift
- Precision bearings used throughout hoist
- Lifetime warranty
- Made in U.S.A.



***WARNING**

Overloading and improper use can result in injury.

To avoid injury:

- Do not exceed working load limit, load rating capacity
- Do not use to lift people or loads over people.
- use only alloy chain for overhead lifting.
- Read and follow all instructions.

ShopStar-Specifications

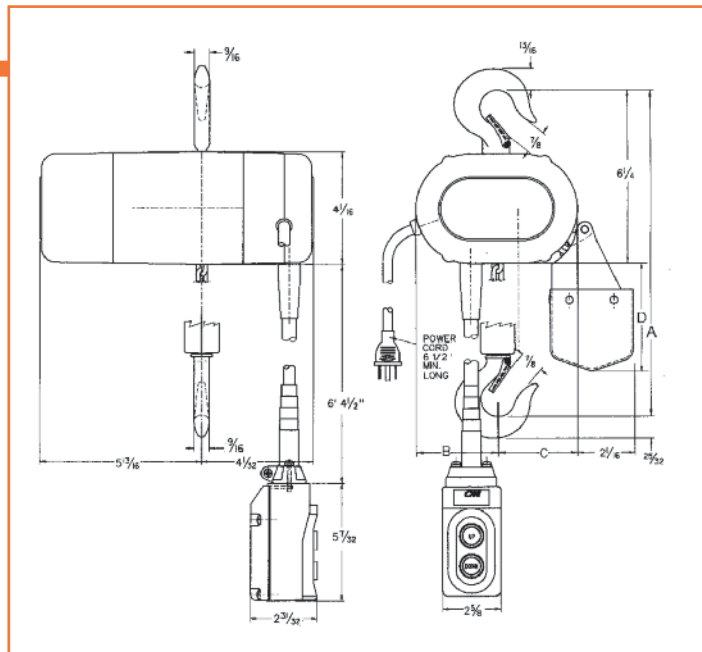

Clearance dimensions (in.)

Reeving	A	B	C	D
Single	11 ¹ / ₁₆	3	2 ¹⁵ / ₁₆	3 ⁷ / ₈
Double	11 ¹⁵ / ₁₆	3 ⁹ / ₁₆	2 ³ / ₈	5 ³ / ₄

Chain Containers

Product code	Single reeved	Double reeved	Approx. Shipping wt., lbs.
2063	10	5	1
2064	20	10	1.4
2065	40	20	1.4
2066	80	40	1.4
2067	120	60	2.2

Specifications

	Product Code			Max. capacity lbs.	Lifting speed F.P.M.	Reeving	Lift ft.	Approx. shipping wt., (lbs.)	Motor H.P.
	115-1-60	230-3-60	460-3-60						
*115-1-60	115-1-60	230-3-60	460-3-60	250	16	single	10	26	1/6
—	2069	2071	2072	250	16	single	10	28	1/6
—	—	2076	2077	250	24	single	10	28	1/6
—	—	2081	2082	250	40	single	10	28	1/6
2000	—	—	—	300	16	single	10	26	1/6
—	2047	2026	2029	300	16	single	10	28	1/6
—	—	2086	2087	300	24	single	10	28	1/6
—	—	2074	2075	300	40	single	10	28	1/6
2095	—	—	—	500	8	double	10	32	1/6
—	2094	2096	2097	500	8	double	10	34	1/6
2090	—	—	—	500	12	single	10	26	1/6
—	2089	2091	2092	500	12	single	10	28	1/6
—	—	2080	2084	500	16	single	10	28	1/6
—	—	2101	2102	500	20	double	10	34	1/6
—	—	2099	2100	500	24	single	10	28	1/6
2001	—	—	—	600	8	double	10	32	1/6
—	2048	2035	2038	600	8	double	10	34	1/6
—	—	2106	2107	600	12	double	10	34	1/6
—	—	2105	2114	600	20	double	10	34	1/6
2110	—	—	—	1000	6	double	10	32	1/6
—	2109	2111	2112	1000	6	double	10	34	1/6
—	—	2116	2117	1000	8	double	10	32	1/6
—	—	2119	2121	1000	12	double	10	32	1/6

*Codes in this column denote units with contactor in push button control station.

ShopStar VS Variable Speed Electric Chain Hoist

The CM® ShopStar VS™ variable speed electric chain hoist is built for rugged industrial and commercial applications where precision load control is critical. This durable hoist features a high H4-plus duty cycle and a compact design ideal for use at workstations and production lines. The ShopStar VS is a superior alternative to air hoists.

STANDARD FEATURES

RUGGED & DURABLE IMPROVED SERVICEABILITY

Thermally protected hoist motor. Rugged, cast aluminum alloy hoist frame and body feature durable epoxy powder-coat finish to protect against corrosion.

LOW MAINTENANCE

Gear train lifetime lubricated with non-oxidizing grease. Totally enclosed hoist frame protects motor from environmental contamination.

COMPACT DESIGN

Small, compact design makes hoist ideal for use in tight spaces and allows for easy installation and maintenance.

OVERLOAD PROTECTION

Standard overload device protects the hoist, operator and surrounding structure from damaging overloads.

LONG CHAIN LIFE

Durable CM Hoistaloy® Load Chain. 10-pocket, oblique-lay lift wheel for longer chain life.

OPTIONAL FEATURES

VARIABLE CONTROLS

3-speed and 3-step infinitely variable controls for single and 3-phase applications.

DURABLE CHAIN CONTAINERS

Impact-resistant plastic/mesh or metal chain containers.

SWIVEL HOOK SUSPENSION

Swivel hook suspension rotates 360° for easy installation and positioning. Swivel hooks are available with latch and Latchlok® latch. Lug mount suspension is also available.

SINGLE- & 3-PHASE VOLTAGE OPTIONS

100 to 240 volt single phase, 50 to 60 Hz. 208 to 240 volt 3 phase. 460 volt and 575 volt 3 phase with optional transformer. 6-1/2 ft. power cord with removable molded, 3-prong 115-volt plug.

H4 PLUS DUTY CYCLE

With 300+ motor starts per hour and Class F motor insulation, the ShopStar VS outperforms the H3 rating of its major competitors.

5:1 DESIGN FACTOR

NEMA 4 INDUSTRIAL-RATED CONTROL SYSTEM

STANDARD RIGID-HOOK SUSPENSION

CM® ROCKET™ PENDANT

Engineered for maximum operator comfort, the CM Rocket delivers precision load control. Pendant features a unique rocker switch and comfort-fit design that increases safety and efficiency. Not available for 3-step infinitely variable hoist models. Pendant with emergency stop not available on ShopStar VS.



The CM ShopStar VS is ideal for applications in the Automotive, Heavy OEM, Utility and Energy industries. Choose this reliable hoist for light assembly workstations that require high speed and precision control lifting with light rail or trolley systems.

In addition, the ShopStar VS is perfect for maintenance and repair applications demanding accurate load control or long lifts.

ShopStar VS Specifications

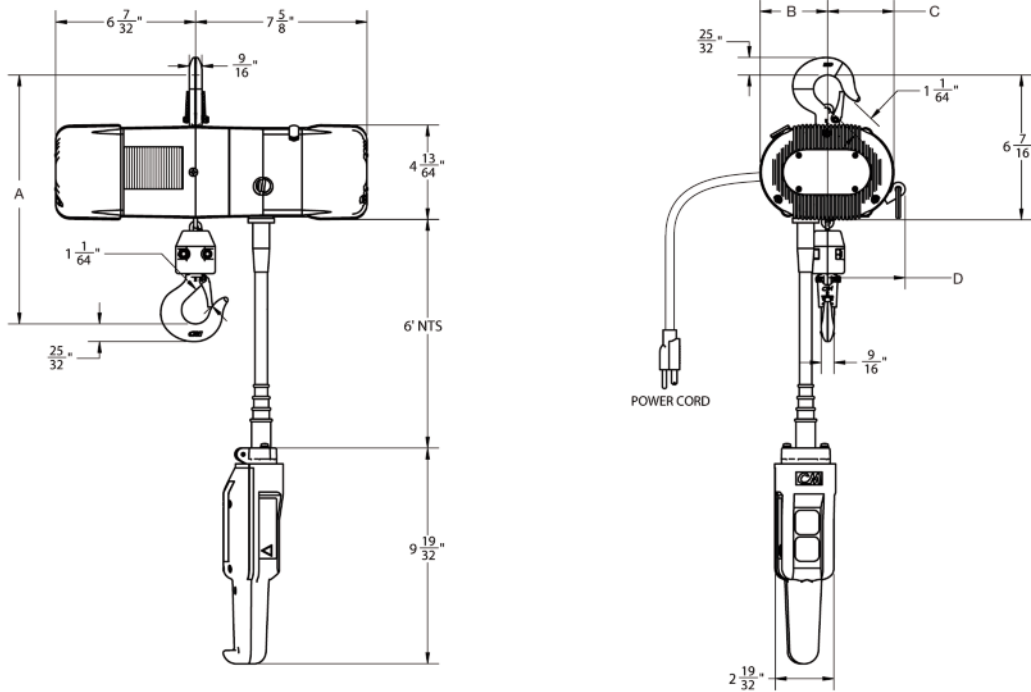

Capacity (Metric Tons)	Product Code				Dimensions in. (mm)				Maximum Lift Speed (ft./min.)	Standard Lift (ft.)	Reeving	Weight (lb.)
	2-Speed	2-Step Infinity Variable Speed	3-Speed	3-Step Infinity Variable Speed	A	B	C	D				
250	VS0250A1	VS0250A2	VS0250A3	VS0250A4	11.06	3	2.95	3.45	63	10	1	26
300	VS0300A1	VS0300A2	VS0300A3	VS0300A4	11.06	3	2.95	3.45	63	10	1	26
500	VS0500A1	VS0500A2	VS0500A3	VS0500A4	11.06	3	2.95	3.45	39	10	1	26
550	VS0550A1	VS0550A2	VS0550A3	VS0550A4	11.06	3	2.95	3.45	26	10	1	26
600	VS0600A1	VS0600A2	VS0600A3	VS0600A4	11.94	3.58	2.36	2.87	31	10	2	28
1000	VS1000A1	VS1000A2	VS1000A3	VS1000A4	11.94	3.58	2.36	2.87	19	10	2	28
1100	VS1100A1	VS1100A2	VS1100A3	VS1100A4	11.94	3.58	2.36	2.87	13	10	2	28

NOTE: Configurable codes and options available in addition to standard products shown above. Optional transformer required for 460-volt applications.

<p>* ⚠ WARNING</p>
<p>Overloading and improper use can result in injury.</p>
<p>To avoid injury:</p> <ul style="list-style-type: none"> • Do not exceed working load limit, load rating capacity • Do not use to lift people or loads over people. • use only alloy chain for overhead lifting. • Read and follow all instructions.

Valustar electric chain hoist

Designed specifically for general commercial applications. This compact, lightweight hoist features:

- Fully machined and heat treated liftwheel with hardened chain guides for smooth chain operation and reduced chain wear
- Standard lift 10, 15 & 20 ft.
- 5 ft. power cord length
- Heavy-duty caliper type AC brake
- Rugged NEMA 4 control station, 115 volt control circuit
- Easy to install and maintain
- Hoist alloy load chain for smooth operation and maximum chain life
- Efficient regenerative braking system to avoid heat generation in power train
- Enclosed hoist duty motor
- Gear train lifetime lubricated with non-oxidizing grease
- Latch type hooks
- Hook suspension standard
- Fully machined and heat treated gear train
- Standard overload Protector device
- H3 duty-1 phase; H-4 duty-3 phase
- Lifetime warranty
- Metric rated
- Made in U.S.A.



Specifications

	Product code		Model	Max. capacity tons	Hoist lifting speed FPM	Reeving	Approximate shipping wt. (lbs.)	
	115-1-60	230/460 3-60					115-1-60	230/460 3-60
Single speed 10' lift	2401	2402	WB	1/4	16	single	54	58
	2403	2404	WF	1/2	16	single	60	58
	2405	2406	WH	1	8	double	70	68
	2407	2408	WL	1	16	single	105	106
	2409	2410	WR	2	8	double	130	122
Single speed 15' lift	2401B	2402B	WB	1/4	16	single	64	62
	2403B	2404B	WF	1/2	16	single	64	62
	2405B	2406B	WH	1	8	double	77	75
	2407B	2408B	WL	1	16	single	111	112
	2409B	2410B	WR	2	8	double	136	128
Single speed 20' lift	2401C	2402C	WB	1/4	16	single	68	66
	2403C	2404C	WF	1/2	16	single	68	66
	2405C	2406C	WH	1	8	double	84	82
	2407C	2408C	WL	1	16	single	116	117
	2409C	2410C	WR	2	8	double	150	142

Longer lifts and modifications available. Apply for details.

Valustar -Specifications

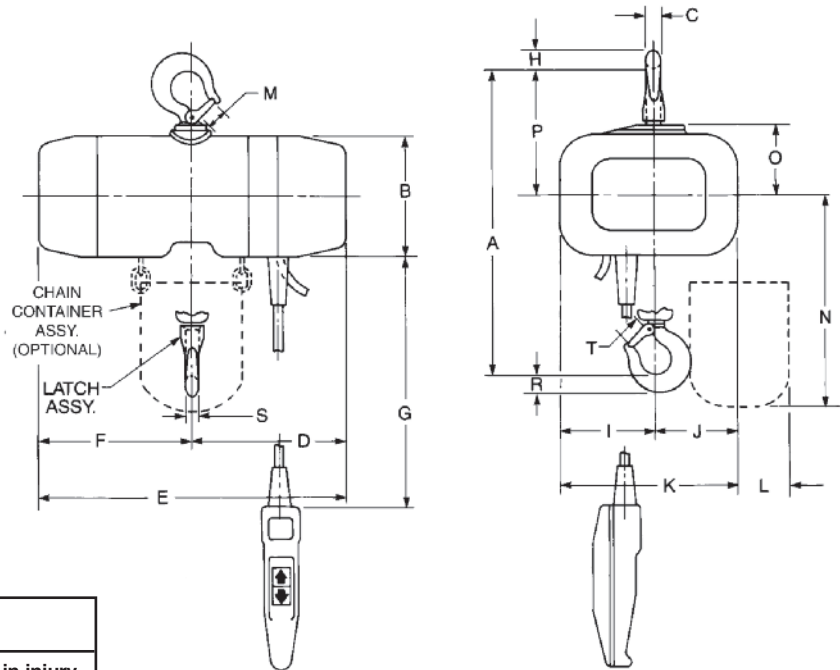

***WARNING**

Overloading and improper use can result in injury.

To avoid injury:

- Do not exceed working load limit, load rating capacity
- Do not use to lift people or loads over people.
- use only alloy chain for overhead lifting.
- Read and follow all instructions.

Clearance dimensions (in.)

Rated capacity* (tons)

Dimension	1/4	1/2	1/2	1	1/2	1	2
	Model WB	Model WF	Model WE	Model WH	Model WJ	Model WL	Model WR
A	14 1/4	14 1/4	17 7/8	17 7/8	15 9/16	15 9/16	22 1/2
B	6 1/8	6 1/8	6 1/8	6 1/8	7 5/8	7 5/8	7 5/8
C	1 1/16	1 1/16	7/8	7/8	7/8	7/8	1 1/8
D	8	8	8	8	9	9	9
E	16 1/16	16 1/16	16 1/16	16 1/16	20 3/16	20 3/16	20 3/16
F	8 1/16	8 1/16	8 1/16	8 1/16	11 3/16	11 3/16	11 3/16
G**	6'-3"	6'-3"	6'-3"	6'-3"	6'-3"	6'-3"	6'-3"
H	1	1	1 3/16	1 3/16	1 3/16	1 3/16	1 1/2
I	4 13/16	4 13/16	3 7/8	3 7/8	7 1/4	7 1/4	6 3/16
J	3 15/16	3 15/16	4 7/8	4 7/8	5 7/16	5 7/16	6 1/2
K	8 3/4	8 3/4	8 3/4	8 3/4	12 11/16	12 11/16	12 11/16
L	1 11/16	1 11/16	1 11/16	1 11/16	7/16	7/16	7/16
M	1	1	1 1/8	1 1/8	1 1/8	1 1/8	1 5/16
N**	12 15/16	12 15/16	15 15/16	15 15/16	16 11/16	16 11/16	22 11/16
O	3 9/16	3 9/16	3 9/16	3 9/16	4	4	4
P	6 9/16	6 3/16	6 1/2	6 1/2	6 7/8	6 7/8	7 3/8
R	1	1	1 3/16	1 3/16	1 3/16	1 3/16	1 1/2
S	1 1/16	1 1/16	7/8	7/8	7/8	7/8	1 1/8
T	1	1	1 1/8	1 1/8	1 1/8	1 1/8	1 5/16

** Based on 10 foot lift units

Powerstar electric chain hoist

Designed specifically as an alternative to wire rope hoists for high speed lifting of loads from 2 to 20 tons in a space saving chain hoist.

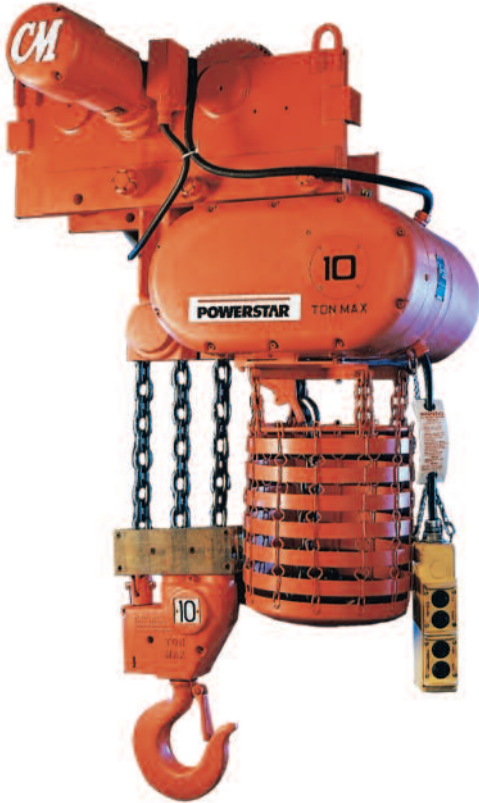

- H-4 or better rated duty cycle
- Designed for heavy-duty industrial applications from 2 to 20 ton capacities
- Liftwheel has machined chain pockets and is heat treated alloy steel for maximum strength and wear resistance
- Efficient regenerative braking system avoids heat generation in power train
- Motors up to 7 1/2 h.p. provide a wide range of lifting speeds
- Single or two speed controls. Two speed models operate on 3:1 speed ratio
- Standard adjustable upper and lower screw limit switches
- Standard overload Protector device
- Hoist alloy load chain can be easily inspected for wear and abuse
- True vertical lift
- Factory tested to 125% of rated capacity prior to shipment
- Metric rated except for 10 & 20 ton capacities
- Rugged aluminum alloy hoist frame
- Chain guide surrounds liftwheel
- Machined and hardened steel Helical gears used throughout hoist for optimum performance and mechanical efficiency.
- Extensive use of life-lubricated bearings plus sealed oil bath power train reservoir for minimum maintenance.
- Dual braking system
- Heavy duty, industrial single speed controls include magnetic reversing contactor which operates on 115 volts provided by a control transformer.
- Totally enclosed, ball bearing, 30 minute rated, thermally protected, hoist duty motor is standard.
- Push button control is weatherproof (NEMA 4 rated).
- Drop of push button control is 4 ft. above hook at lowest position, unless otherwise specified.
- External push button chain strain relief is standard.
- Power cord length is 2 1/2 ft. unless otherwise specified.
- Trolley design permits easy adjustment for installation on a broad range of beam flange widths.
- Trolley wheels have double row, tapered roller bearings plus machined and hardened universal treads to permit operation on American Standard or flat flanged sections interchangeably.
- Spur gearing used in all motorized trolleys for improved efficiency and durability.
- Drop of hand chain on geared trolleys is 2 ft. above hook at lowest position, unless otherwise specified.
- Designed to be maintained "on the beam."
- Up to 600 lineal feet of chain
- Weatherproof (NEMA3R)
- Lifetime warranty
- Made in U.S.A.

***WARNING**

Overloading and improper use can result in injury.

To avoid injury:

- Do not exceed working load limit, load rating capacity
- Do not use to lift people or loads over people.
- use only alloy chain for overhead lifting.
- Read and follow all instructions.

Powerstar-Specifications

Specifications – standard unit

Rated capacity* (tons)	Single speed			Two speed			Reeving (single)	Std. lift** (ft.)	HP	Headroom w/lug suspension (in.)	Headroom w/trolley suspension (in.)	Hoist only approx. shipping weight	
	Lifting speed (F.P.M.)	Product code 230-3-60	Product code 460-3-60	Lifting speed (F.P.M.)	Product code 230-3-60	Product code 460-3-60						Single speed hoist (lbs.)	Two speed hoist (lbs.)
2	20	7300	7301	20/7	7302	7303	1	20	5	28 ¹⁵ / ₁₆	30 ¹⁵ / ₁₆	392	402
	24	7001	7002	24/8	7003	7004	1	20	5	28 ¹⁵ / ₁₆	30 ¹⁵ / ₁₆	392	402
	32	7304	7305	32/11	7306	7037	1	20	5	28 ¹⁵ / ₁₆	30 ¹⁵ / ₁₆	404	414
	40	7005	7006	40/13	7007	7008	1	20	5	28 ¹⁵ / ₁₆	30 ¹⁵ / ₁₆	404	414
	48	7308	7309	48/16	7310	7311	1	20	7.5	28 ¹⁵ / ₁₆	30 ¹⁵ / ₁₆	408	418
3	20	7312	7313	20/7	7314	7315	1	20	5	28 ¹⁵ / ₁₆	31 ¹ / ₂	404	414
	24	7009	7010	24/8	7011	7012	1	20	5	28 ¹⁵ / ₁₆	31 ¹ / ₂	404	414
	32	7316	7317	32/11	7318	7319	1	20	7.5	28 ¹⁵ / ₁₆	31 ¹ / ₂	408	418
	40	7013	7014	40/13	7015	7016	1	20	7.5	28 ¹⁵ / ₁₆	31 ¹ / ₂	408	418
4	10	7320	7321	10/3	7322	7323	2	20	5	34	36 ⁹ / ₁₆	478	488
	12	7324	7325	12/4	7326	7327	2	20	5	34	36 ⁹ / ₁₆	490	500
	16	7328	7329	16/5	7330	7331	2	20	5	34	36 ⁹ / ₁₆	490	500
	20	7332	7333	20/7	7334	7335	2	20	7.5	34	36 ⁹ / ₁₆	490	500
	24	7336	7337	24/8	7338	7339	2	20	7.5	34	36 ⁹ / ₁₆	494	504
5	10	7340	7341	10/3	7342	7343	2	20	5	34	36 ⁹ / ₁₆	478	488
	12	7344	7345	12/4	7346	7347	2	20	5	34	36 ⁹ / ₁₆	478	488
	16	7029	7030	16/5	7031	7032	2	20	5	34	36 ⁹ / ₁₆	490	500
	20	7348	7349	20/7	7350	7351	2	20	7.5	34	36 ⁹ / ₁₆	494	500
	24	7017	7018	24/8	7019	7020	2	20	7.5	34	36 ⁹ / ₁₆	494	504
6	10	7352	7353	10/3	7354	7355	2	20	5	34	36 ⁹ / ₁₆	548	558
	12	7052	7053	12/4	7054	7055	2	20	5	34	36 ⁹ / ₁₆	548	558
	16	7356	7357	16/5	7358	7359	2	20	7.5	34	36 ⁹ / ₁₆	552	562
	20	7056	7057	20/7	7058	7059	2	20	7.5	34	36 ⁹ / ₁₆	552	562
7 ¹ / ₂	7	7360	7361	7/2	7362	7363	3	20	5	Apply	39 ³ / ₈	594	604
	8	7364	7365	8/3	7366	7367	3	20	5	Apply	39 ³ / ₈	606	616
	11	7368	7369	11/4	7370	7371	3	20	5	Apply	39 ³ / ₈	606	616
	14	7372	7373	14/5	7374	7375	3	20	7.5	Apply	39 ³ / ₈	622	632
	16	7376	7377	16/5	7378	7379	3	20	7.5	Apply	39 ³ / ₈	622	632
9	7	7380	7381	7/2	7382	7383	3	20	5	Apply	41 ³ / ₁₆	610	620
	8	7384	7385	8/3	7386	7387	3	20	5	Apply	41 ³ / ₁₆	610	620
	11	7388	7389	11/4	7390	7391	3	20	7.5	Apply	41 ³ / ₁₆	626	636
	13	7392	7393	13/4	7394	7395	3	20	7.5	Apply	41 ³ / ₁₆	626	636
10	7	7396	7397	7/2	7398	7399	3	20	5	Apply	41 ³ / ₁₆	610	620
	8	7400	7401	8/3	7402	7403	3	20	5	Apply	41 ³ / ₁₆	610	620
	11	7404	7405	11/4	7406	7407	3	20	7.5	Apply	41 ³ / ₁₆	626	636
	13	7408	7409	13/4	7410	7411	3	20	7.5	Apply	41 ³ / ₁₆	626	636
12	5	7412	7413	5/2	7414	7415	4	20	5	Apply	41 ³ / ₁₆	710	720
	6	7416	7417	6/2	7418	7419	4	20	5	Apply	41 ³ / ₁₆	710	720
	8	7420	7421	8/3	7422	7423	4	20	7.5	Apply	41 ³ / ₁₆	726	736
	10	7424	7425	10/3	7426	7427	4	20	7.5	Apply	41 ³ / ₁₆	726	736
15	4	7428	7429	4/1.3	7430	7431	5	20	5	Apply	47 ⁵ / ₁₆	805	815
	5	7432	7433	5/1.5	7434	7435	5	20	5	Apply	47 ⁵ / ₁₆	805	815
	6	7436	7437	6/2	7438	7439	5	20	7.5	Apply	47 ⁵ / ₁₆	817	827
	8	7440	7441	8/2.5	7442	7443	5	20	7.5	Apply	47 ⁵ / ₁₆	817	827

** 20 ft. lift is standard — for other lifts, apply.

Powerstar with lug suspension

2, 3, 4, 5 & 6 ton capacities (for 7½ - 15 ton capacities, consult factory)

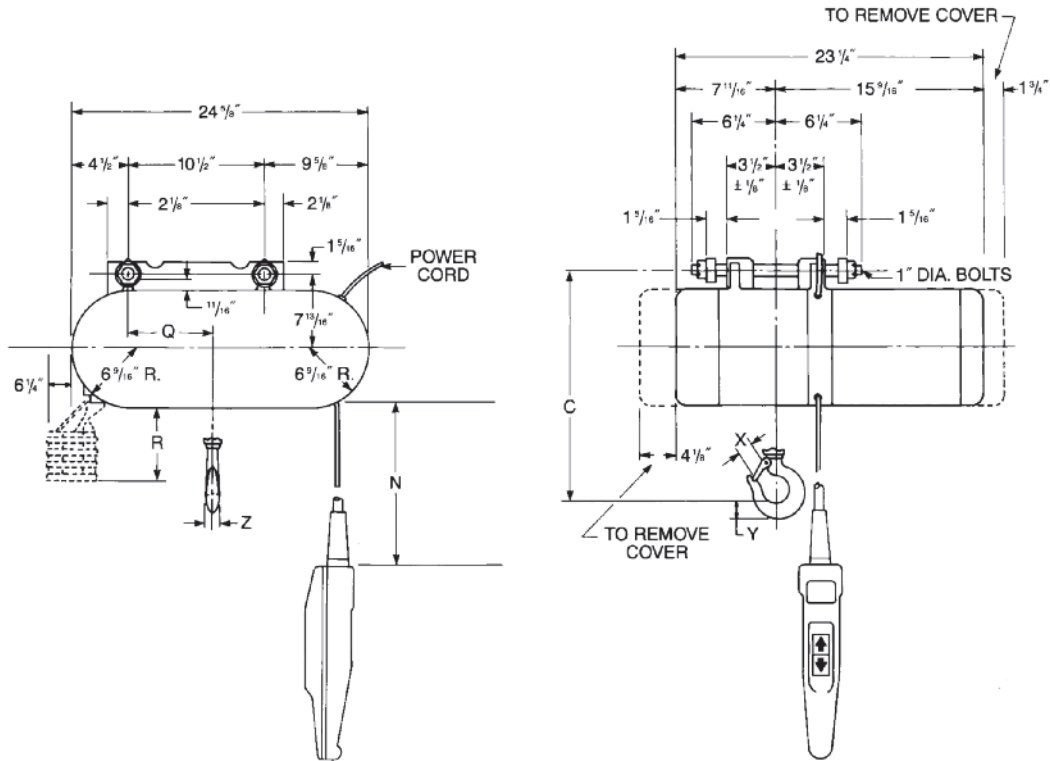

Clearance dimensions (in.)

Dimension	Rated capacity* (tons)				
	2	3	4	5	6
C	28 ¹⁵ / ₁₆	28 ¹⁵ / ₁₆	34	34	34
N**	16'-7"	16'-7"	16'-7"	16'-7"	16'-7"
Q	3 ³ / ₄	3 ³ / ₄	5 ⁷ / ₈	5 ⁷ / ₈	5 ⁷ / ₈
R**	18 ¹ / ₁₆	18 ¹ / ₁₆	26 ³ / ₁₆	26 ³ / ₁₆	26 ³ / ₁₆
X	1 ⁵ / ₈	1 ⁵ / ₈	2 ⁵ / ₁₆	2 ⁵ / ₁₆	2 ⁵ / ₁₆
Y	1 ¹ / ₁₆	1 ¹ / ₁₆	2 ⁹ / ₁₆	2 ⁹ / ₁₆	2 ⁹ / ₁₆
Z	1 ¹ / ₄	1 ¹ / ₄	1 ¹³ / ₁₆	1 ¹³ / ₁₆	1 ¹³ / ₁₆

** Applies to 20 foot lift units

All dimensions are in inches and are based on minimum American standard section.

* **WARNING**

Overloading and improper use can result in injury.

To avoid injury:

- Do not exceed working load limit, load rating capacity
- Do not use to lift people or loads over people.
- use only alloy chain for overhead lifting.
- Read and follow all instructions.

Powerstar with plain or geared trolley

2, 3, 4, 5 & 6 ton capacities

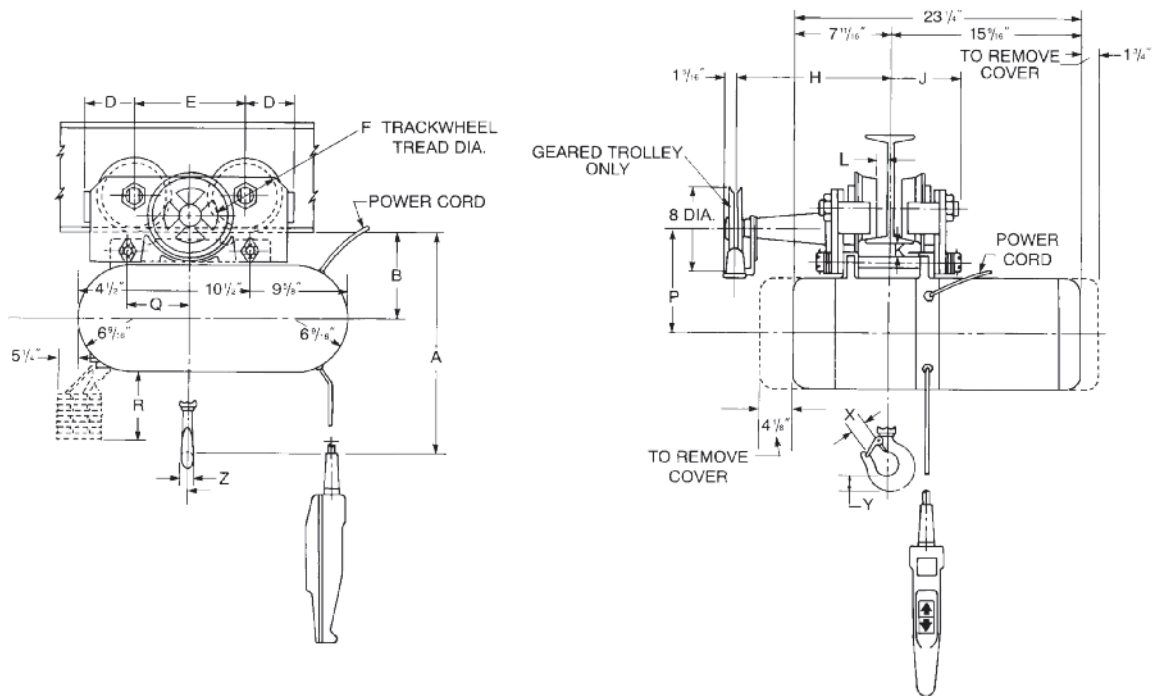

Clearance dimensions (in.)

Dimension	Rated capacity* (tons)				
	2	3	4	5	6
A	30 ¹⁵ / ₁₆	31 ¹ / ₂	36 ⁹ / ₁₆	36 ⁹ / ₁₆	36 ⁹ / ₁₆
B	9 ¹³ / ₁₆	10 ³ / ₈	10 ³ / ₈	10 ³ / ₈	10 ³ / ₈
D	3 ¹ / ₂	4 ⁹ / ₁₆	4 ⁹ / ₁₆	4 ⁹ / ₁₆	4 ⁹ / ₁₆
E	9 ¹ / ₂	10 ¹ / ₂	10 ¹ / ₂	10 ¹ / ₂	10 ¹ / ₂
F	4 ¹¹ / ₁₆	5 ¹³ / ₁₆	5 ¹³ / ₁₆	5 ¹³ / ₁₆	5 ¹³ / ₁₆
H	12 ¹³ / ₁₆	14 ¹ / ₈	14 ¹ / ₈	14 ¹ / ₈	14 ¹ / ₈
J	5	6 ¹ / ₄	6 ¹ / ₄	6 ¹ / ₄	6 ¹ / ₄
K	1 ¹ / ₁₆	1 ¹ / ₄	1 ¹ / ₄	1 ¹ / ₄	1 ¹ / ₄
L	1/2	1 ⁵ / ₁₆	1 ⁵ / ₁₆	1 ⁵ / ₁₆	1 ⁵ / ₁₆
P	11 ⁹ / ₁₆	11 ¹⁵ / ₁₆	11 ¹⁵ / ₁₆	11 ¹⁵ / ₁₆	11 ¹⁵ / ₁₆
Q	3 ³ / ₄	3 ³ / ₄	5 ⁷ / ₈	5 ⁷ / ₈	5 ⁷ / ₈
R**	18 ¹ / ₁₆	18 ¹ / ₁₆	26 ³ / ₁₆	26 ³ / ₁₆	26 ³ / ₁₆
X	1 ⁵ / ₈	1 ⁵ / ₈	2 ⁵ / ₁₆	2 ⁵ / ₁₆	2 ⁵ / ₁₆
Y	1 ¹ / ₁₆	1 ¹ / ₁₆	2 ⁹ / ₁₆	2 ⁹ / ₁₆	2 ⁹ / ₁₆
Z	1 ¹ / ₄	1 ¹ / ₄	1 ¹³ / ₁₆	1 ¹³ / ₁₆	1 ¹³ / ₁₆

**Std. 20 foot lift

All dimensions are in inches and are based on minimum American standard section.

Specifications

Rated capacity* (tons)	Plain trolley		Geared trolley†		Std. range of adjust. Am. std. S-beams		Min. radius curve (in.)
	Product code	Shipping weight (lbs.)	Product code	Shipping weight (lbs.)	Min. beam size	Max. beam size	
2	5973	98	5964	175	S6 x 12.5# x 3.33"	S15 x 42.9# x 5.5"	48
3-6	5971	176	5972	295	S12 x 31.8# x 5"	S20 x 65.4# x 6.25"	66

† Standard hand chain drop is in proportion to 20 ft. lift. For other lifts, apply to the factory.

Powerstar with motor driven trolley

2, 3, 4, 5 & 6 ton capacities

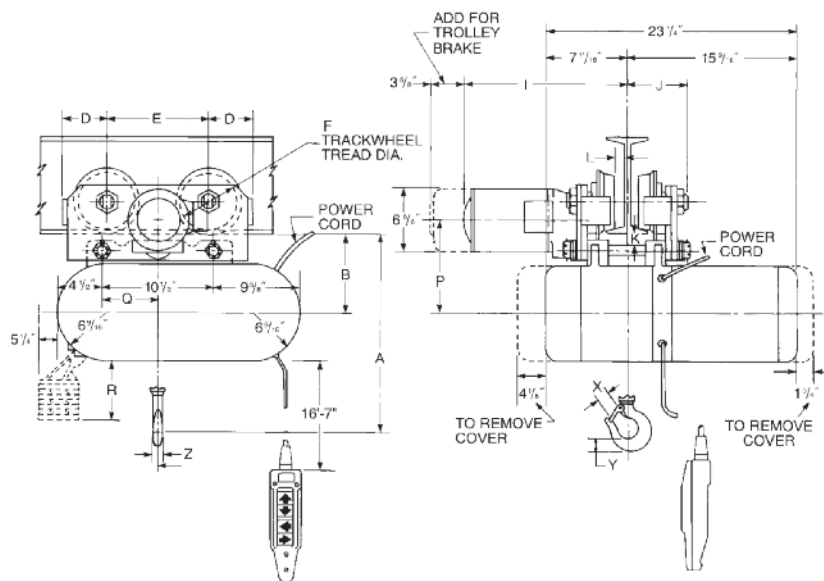

Clearance dimensions (in.)

Dimension	Rated capacity* (tons)				
	2	3	4	5	6
A	30 ¹⁵ / ₁₆	31 ¹ / ₂	36 ⁹ / ₁₆	36 ⁹ / ₁₆	36 ⁹ / ₁₆
B	9 ¹³ / ₁₆	10 ³ / ₈	10 ³ / ₈	10 ³ / ₈	10 ³ / ₈
D	3 ¹ / ₂	4 ⁹ / ₁₆	4 ⁹ / ₁₆	4 ⁹ / ₁₆	4 ⁹ / ₁₆
E	9 ¹ / ₂	10 ¹ / ₂	10 ¹ / ₂	10 ¹ / ₂	10 ¹ / ₂
F	4 ¹¹ / ₁₆	5 ¹³ / ₁₆	5 ¹³ / ₁₆	5 ¹³ / ₁₆	5 ¹³ / ₁₆
I	17 ⁷ / ₁₆	18 ⁵ / ₈	18 ⁵ / ₈	18 ⁵ / ₈	18 ⁵ / ₈
J	5	6 ¹ / ₄	6 ¹ / ₄	6 ¹ / ₄	6 ¹ / ₄
K	1 ¹ / ₁₆	1 ¹ / ₄	1 ¹ / ₄	1 ¹ / ₄	1 ¹ / ₄
L	1/2	1 ⁵ / ₁₆	1 ⁵ / ₁₆	1 ⁵ / ₁₆	1 ⁵ / ₁₆
P	11 ⁹ / ₁₆	11 ¹⁵ / ₁₆	11 ¹⁵ / ₁₆	11 ¹⁵ / ₁₆	11 ¹⁵ / ₁₆
Q	3 ³ / ₄	3 ³ / ₄	5 ⁷ / ₈	5 ⁷ / ₈	5 ⁷ / ₈
R**	18 ¹ / ₁₆	18 ¹ / ₁₆	26 ³ / ₁₆	26 ³ / ₁₆	26 ³ / ₁₆
X	1 ⁵ / ₈	1 ⁵ / ₈	2 ⁵ / ₁₆	2 ⁵ / ₁₆	2 ⁵ / ₁₆
Y	1 ¹ / ₁₆	1 ¹ / ₁₆	2 ⁹ / ₁₆	2 ⁹ / ₁₆	2 ⁹ / ₁₆
Z	1 ¹ / ₄	1 ¹ / ₄	1 ¹³ / ₁₆	1 ¹³ / ₁₆	1 ¹³ / ₁₆

**Applies to 20 foot lift units

All dimensions are in inches and are based on minimum American standard section

Specifications — trolley

Rated capacity* (tons)	Speed (F.P.M.)	Product code		Approx. shipping weight (lbs.)	Standard range of adjustability		Min. curve (in.)
		230-3-60	460-3-60		Min. beam size	Max. beam size	
2	65	7064	7065	168	S6 x 12.5# x 3.33"	S15 x 42.9# x 5.5"	48
2	100	7066	7067	168	S6 x 12.5# x 3.33"	S15 x 42.9# x 5.5"	48
3	50	7068	7069	250	S12 x 31.8# x 5"	S20 x 66# x 6.25"	66
4	50	7545	7585	255	S12 x 31.8# x 5"	S20 x 66# x 6.25"	66
5	50	7070	7071	255	S12 x 31.8# x 5"	S20 x 66# x 6.25"	66
6	50	7072	7073	255	S12 x 31.8# x 5"	S20 x 66# x 6.25"	66

Apply for other than standard trolley speeds and for other than standard beam adjustment

Powerstar with plain or geared trolley

7½, 9, 10, 12 & 15 ton capacities

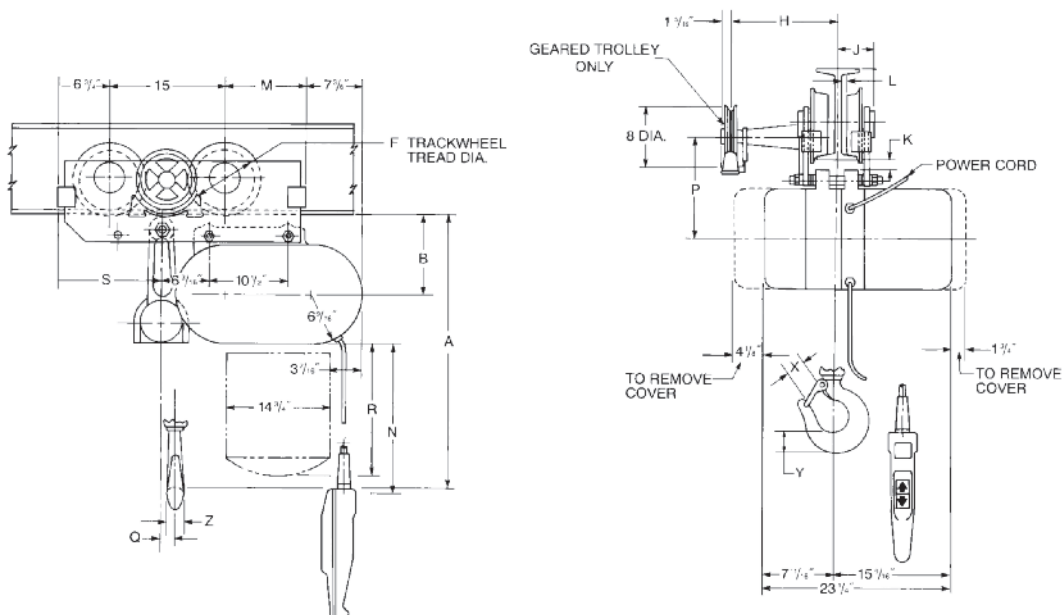

Clearance dimensions (in.)

Dimension	Rated capacity* (tons)				
	7½	9	10	12	15
A	39 ³ / ₈	41 ³ / ₁₆	41 ³ / ₁₆	41 ³ / ₁₆	47 ¹⁵ / ₁₆
B	11 ¹³ / ₁₆	11 ¹³ / ₁₆	11 ¹³ / ₁₆	11 ⁹ / ₁₆	11 ⁹ / ₁₆
F	8	8	8	8	8
H	14	14¼	14¼	14¾	13 ¹³ / ₁₆
J	5 ¹ / ₈	5 ³ / ₈	5 ³ / ₈	5 ⁷ / ₈	5 ⁷ / ₈
K	1½	1 ⁷ / ₁₆	1 ⁷ / ₁₆	1¼	1¼
L	¾	1 ⁵ / ₁₆	1 ⁵ / ₁₆	1 ¹ / ₁₆	1 ¹ / ₁₆
M	10¾	10¾	10¾	10¾	13 ³ / ₁₆
N**	17'-10"	17'-10"	17'-10"	17'-10"	17'-10"
P	16 ⁵ / ₁₆	16 ⁵ / ₁₆	16 ⁵ / ₁₆	16 ⁵ / ₁₆	16 ⁵ / ₁₆
Q	1 ⁵ / ₁₆	1 ⁵ / ₁₆	1 ⁵ / ₁₆	0	-1 ¹³ / ₁₆
R**	21½	21½	21½	26 ¹ / ₈	31 ¹ / ₈
S	12 ¹³ / ₁₆	12 ¹³ / ₁₆	12 ¹³ / ₁₆	12 ¹³ / ₁₆	16 ¹ / ₈
X	2 ⁵ / ₁₆	3	3	3	3 ⁵ / ₈
Y	2 ⁹ / ₁₆	3	3	3	3 ⁵ / ₈
Z	1 ¹³ / ₁₆	2 ³ / ₈	2 ³ / ₈	2 ³ / ₈	3

** Applies to 20 foot lift units

All dimensions are in inches and are based on minimum American standard section.

Specifications

Rated capacity* (tons)	Plain trolley		Geared trolley†		Std. range of adjust. Am. std. S-beams		Min. radius curve (in.)
	Product code	Shipping weight (lbs.)	Product code	Shipping weight (lbs.)	Min. beam size	Max. beam size	
7½	7205	335	7209	395	S15 x 42.9# x 5.5"	S24 x 100# x 7.25"	*
9	7206	335	7210	395	S18 x 54.7# x 6"	S24 x 121# x 8"	*
10	7207	335	7211	395	S18 x 54.7# x 6"	S24 x 121# x 8"	*
12	7208	335	7212	395	S20 x 86# x 7"	S24 x 121# x 8"	*
15	7530	350	7532	410	S20 x 86# x 7"	S24 x 121# x 8"	*

* Trolleys suitable for straight track operation only as standard. For curved beam applications, please contact sales department.

† Standard hand chain drop is in proportion to 20 ft. lift. For other chain drops, apply to factory.

Powerstar with motor driven trolley

7½, 9, 10, 12 & 15 ton capacities

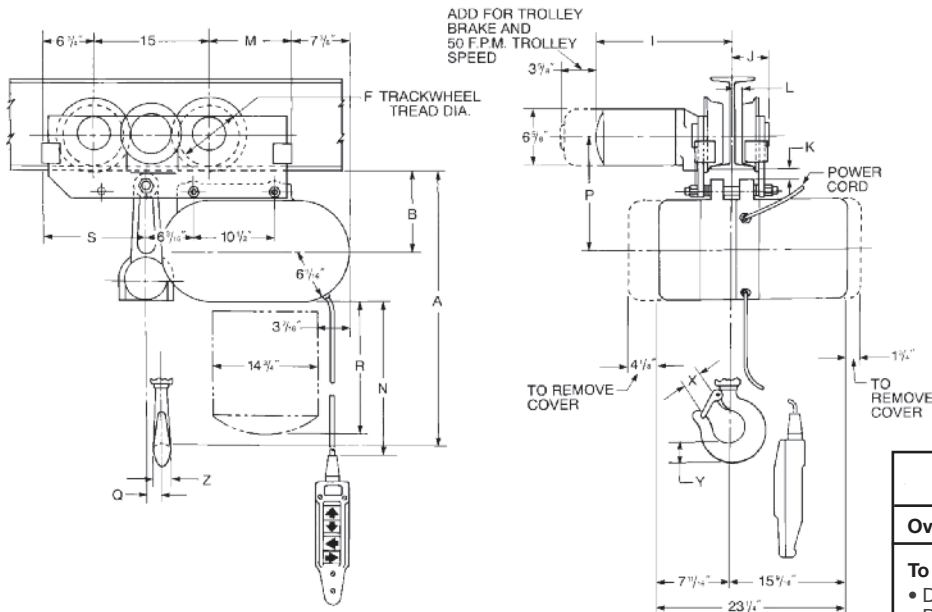

***WARNING**

Overloading and improper use can result in injury.

To avoid injury:

- Do not exceed working load limit, load rating capacity
- Do not use to lift people or loads over people.
- use only alloy chain for overhead lifting.
- Read and follow all instructions.

Clearance dimensions (in.)

Dimension	Rated capacity* (tons)				
	7½	9	10	12	15
A	39⅜	41⅜ ₁₆	41⅜ ₁₆	41⅜ ₁₆	47 ¹⁵ / ₁₆
B	11 ¹³ / ₁₆	11 ¹³ / ₁₆	11 ¹³ / ₁₆	11 ⁹ / ₁₆	11 ⁹ / ₁₆
F	8	8	8	8	8
I	18	18¼	18¼	19 ⁵ / ₈	18 ⁷ / ₁₆
J	5 ¹ / ₈	5 ³ / ₈	5 ³ / ₈	5 ⁷ / ₈	5 ⁷ / ₈
K	1½	1 ⁷ / ₁₆	1 ⁷ / ₁₆	1¼	1¼
L	¾	1 ⁵ / ₁₆	1 ⁵ / ₁₆	1 ¹ / ₁₆	1 ¹ / ₁₆
M	10 ³ / ₄	10 ³ / ₄	10 ³ / ₄	10 ³ / ₄	13 ³ / ₁₆
N**	17'-10"	17'-10"	17'-10"	17'-10"	17'-10"
P	16 ⁹ / ₁₆	16 ⁵ / ₁₆	16 ⁹ / ₁₆	16 ⁵ / ₁₆	16 ⁹ / ₁₆
Q	1 ⁵ / ₁₆	1 ⁵ / ₁₆	1 ⁵ / ₁₆	0	-1 ³ / ₁₆
R**	21½	21½	21½	26 ¹ / ₈	31 ¹ / ₈
S	12 ¹³ / ₁₆	12 ¹³ / ₁₆	12 ¹³ / ₁₆	12 ¹³ / ₁₆	16 ¹ / ₁₆
X	2 ⁵ / ₁₆	3	3	3	3 ⁵ / ₈
Y	2 ⁹ / ₁₆	3	3	3	3 ⁵ / ₈
Z	1 ¹³ / ₁₆	2 ³ / ₈	2 ³ / ₈	2 ³ / ₈	3

** Applies to 20 foot lift units.

All dimensions are in inches and are based on minimum American standard section

Specifications — trolley

Rated capacity* (tons)	Speed (F.P.M.)	Product code		Approx. shipping weight (lbs.)	Standard range of adjustability Am. std. S-beams		Min. radius curve (in.)
		230-3-60	460-3-60		Min. beam size	Max. beam size	
7½	35	7224	7224	390	S15 x 42.9# x 5.5"	S24 x 100# x 7.25"	*
9	35	7225	7225	390	S18 x 54.7# x 6"	S24 x 121# x 8"	*
10	35	7226	7226	390	S18 x 54.7# x 6"	S24 x 121# x 8"	*
12	35	7227	7227	390	S20 x 86# x 7"	S24 x 121# x 8"	*
15	35	7571	7299	405	S20 x 86# x 7"	S24 x 121# x 8"	*

Apply for other than standard trolley speeds and other than standard beam adjustment

* Trolleys suitable for straight track operation only as standard. For curved beam applications, please contact sales department.

Lodestar Air XL Pneumatic Chain Hoist



Lodestar Air XL chain hoists with capabilities from 2 to 7¹/₂ tons provides heavy-duty hoists featuring variable speeds and higher capacities than traditional air chain hoists. Workers in automotive plants, heavy equipment manufacturing, chemical plants, refineries, and related rugged work environments will experience the same dependability and versatility that they have relied on from CM products for many years.

The features of the Lodestar Air XL Chain Hoist includes:

- Lifting capacities up to 7¹/₂ tons
- Variable lifting speeds
- Maximum lifting speed of 31 feet per minute
- Forged ten-pocket oblique-lay liftwheel for smooth chain operation, constant chain speed, and reduced chain wear
- Standard overload protector
- Clutch acts as upper and lower limits
- Six-vane rotary air motor
- Pendant controls provide precise load spotting
- Air actuated motor brake for positive load control
- Factory tested at 125% of rated capacity
- Spark resistant models available
- Lifetime warranty
- Made in U.S.A.
- Standard Lift: 10 ft.
- Air inlet size: 1" NPT
- Air supply hose size: 1" I.D. min.
- Consumption: 175 CFM at 90 PSI
- Exhaust: 1 1/4" NPT

Lodestar Air XL with Hook Suspension-Specifications

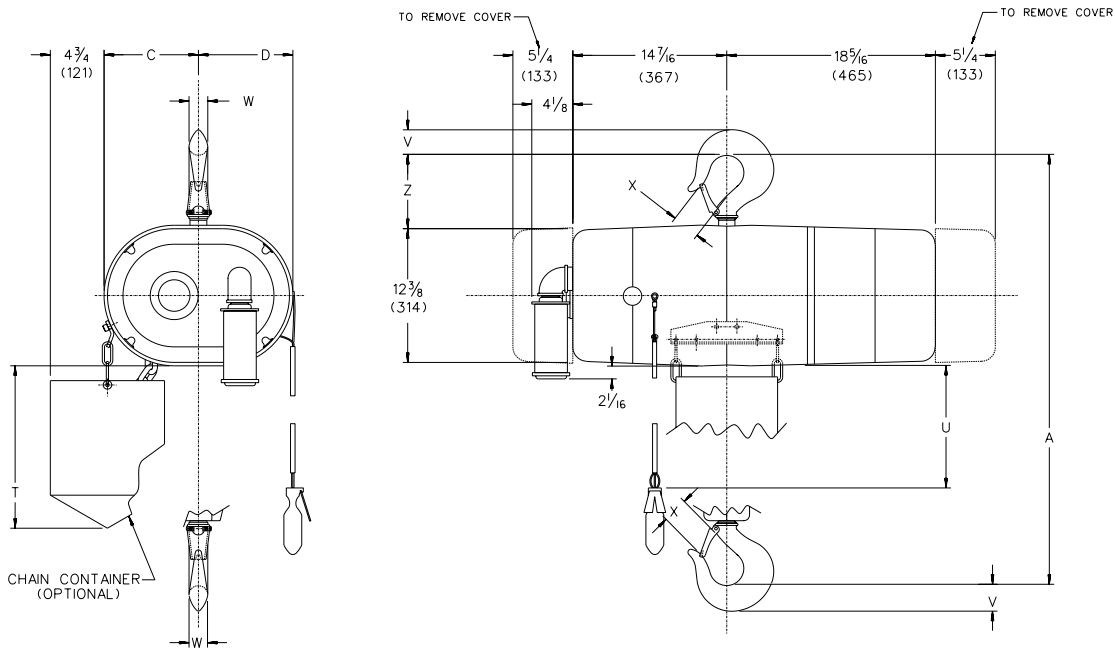

Clearance Dimensions (inches)**

Dimensions	Single Reeved 2 ton capacity	Double Reeved 3-5 ton capacity	Triple Reeved 6 ton capacity
A	25	35 ⁵ / ₁₆	36 ³ / ₁₆
C	8 ⁷ / ₁₆	11 ³ / ₈	11 ³ / ₈
D	8 ¹ / ₈	5 ¹ / ₂	5 ¹ / ₂
T (based on 10 ft. lift)	14 ³ / ₁₆	14 ³ / ₁₆	14 ³ / ₁₆
U (based on 10 ft. lift)	6'- 3"	6'- 3"	6'- 3"
V	1 ¹ / ₂	2 ¹ / ₄	2 ¹ / ₄
W	1 ¹ / ₈	1 ⁵ / ₈	1 ⁵ / ₈
X	1 ⁵ / ₁₆	2 ¹ / ₁₆	2 ¹ / ₁₆
Z	4 ¹ / ₈	5 ¹ / ₂	5 ¹ / ₂
Weight (lbs.)	347	421	453
Lifting Speed (FPM)	31	21/13	10

**Dimensions listed are for minimum size "S" beam.

CM[®] Repair/Replacement Policy

All Hoists are thoroughly inspected and performance tested prior to shipment. If any properly maintained CM Hoist develops a performance problem due to a material or workmanship defect, as verified by Columbus McKinnon, repair or replacement of the hoist will be made to the original purchaser without charge. This repair/replacement policy applies only to Hoists installed, maintained and operated as outlined in the applicable accompanying CM Hoist Manual, and specifically excludes normal wear, abuse, improper installation, improper or inadequate maintenance, hostile environmental effects, and unauthorized repairs/modifications.

ANSI/OSHA

CM hoists are manufactured in accordance with our interpretation of the ASME/ANSI Code B30.16 for Overhead Hoists and U.S. Occupational Safety and Health Act regulations at the time of manufacture. Users should check each installation for compliance with the application, operation and maintenance requirements of these regulations and standards.

Lodestar Air XL with plain trolley and geared trolley-Specifications

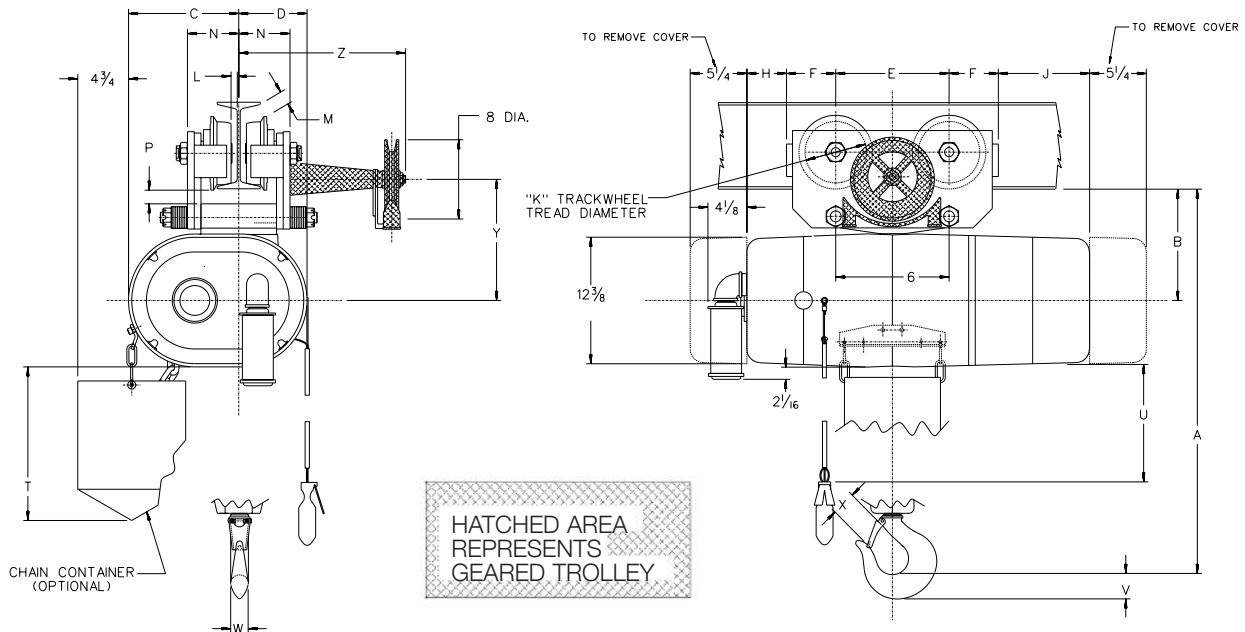

Clearance Dimensions (inches)**

Dimensions	Single Reeved	Double Reeved		Triple Reeved
	2 ton capacity	3 ton capacity	5 ton capacity	6 & 7 1/2 ton capacity
A	28 ¹¹ / ₁₆	33 ¹ / ₂	33 ³ / ₄	34 ⁵ / ₈
B	9 ³ / ₄	10 ⁷ / ₁₆	10 ¹¹ / ₁₆	10 ¹ / ₁₆
C	8 ⁷ / ₁₆	11 ³ / ₈	11 ³ / ₈	11 ³ / ₈
D	8 ³ / ₈	5 ¹ / ₂	5 ¹ / ₂	5 ¹ / ₂
E	9 ¹ / ₂	9 ¹ / ₈	12	12
F	3 ¹ / ₂	3 ¹ / ₄	4 ¹³ / ₁₆	4 ¹³ / ₁₆
H	5 ¹ / ₄	5 ¹¹ / ₁₆	2 ¹¹ / ₁₆	2 ¹¹ / ₁₆
J	10 ¹ / ₁₆	10 ¹ / ₂	7 ¹ / ₂	7 ¹ / ₂
K	4 ¹¹ / ₁₆	4	6 ¹ / ₂	6 ¹ / ₂
L	1/2	5/8	5/8	5/8
M	1/2	2 ¹¹ / ₁₆	0	0
N	5	3 ⁵ / ₈	3 ⁷ / ₈	3 ⁷ / ₈
P	1 ¹ / ₄	3/8	7/16	7/16
T (based on 10 ft. lift)	14 ³ / ₁₆	14 ³ / ₁₆	14 ³ / ₁₆	14 ³ / ₁₆
U (based on 10 ft. lift)	6'- 3"	6'- 3"	6'- 3"	6'- 3"
V	1 ¹ / ₂	2 ¹ / ₄	2 ¹ / ₄	2 ¹ / ₄
W	1 ¹ / ₈	1 ⁵ / ₈	1 ⁵ / ₈	1 ⁵ / ₈
X	1 ⁵ / ₁₆	2 ¹ / ₁₆	2 ¹ / ₁₆	2 ¹ / ₁₆
Y*	11 ⁵ / ₁₆	12 ⁷ / ₈	11 ¹ / ₈	11 ¹ / ₈
Z*	-	19 ¹ / ₈	19 ¹ / ₈	19 ¹ / ₈
Weight (lbs.)-Plain Trolley	407	476	576	608
Weight (lbs.)-Geared Trolley	452	491	586	618
Minimum Radius Curve (ft.)	4	4	6	6
Standard Beam Flange Adj. Range (in.)	3.33-5.55	4.00-6.25	4.00-6.25	4.00-6.25
Lifting Speed (FPM)	31	21	13	10/9

*Geared Trolley Dimensions Only

**Dimensions listed are for minimum size "S" beam.

Lodestar Air XL with Motor Driven Trolley-Specifications

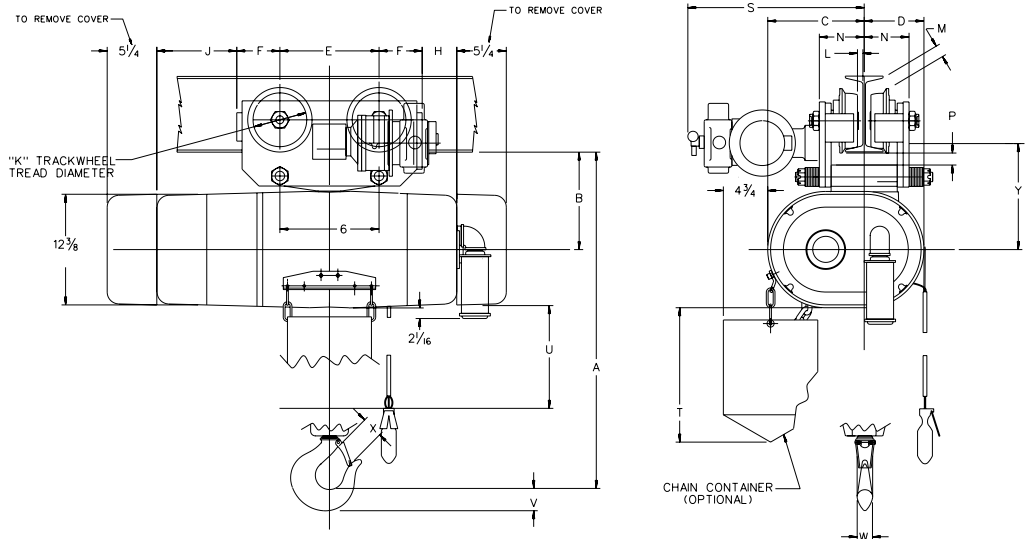

Clearance Dimensions (inches)**

Dimensions	Double Reeved		Triple Reeved	
	2 ton capacity	3 ton capacity	5 ton capacity	6 & 7½ ton capacity
A	33½	33½	33¾	34⅝
B	10⅞	10⅞	10⅞	10⅞
C	9⅝	11⅜	11⅜	11⅜
D	7⅞	5½	5½	5½
E	9⅞	9⅞	12	12
F	3¼	3¼	4⅜	4⅜
H	5⅞	5⅞	2⅞	2⅞
J	10½	10½	7½	7½
K	4	4	6½	6½
L	⅝	⅝	⅝	⅝
M	2⅞	2⅞	0	0
N	3⅝	3⅝	3⅞	3⅞
P	⅜	⅜	⅞	⅞
S	15⅞	15⅞	17¾	17¾
T (based on 10 ft. lift)	14⅞	14⅞	14⅞	14⅞
U (based on 10 ft. lift)	6'- 3"	6'- 3"	6'- 3"	6'- 3"
V	2¼	2¼	2¼	2¼
W	1⅝	1⅝	1⅝	1⅝
X	2⅞	2⅞	2⅞	2⅞
Minimum Radius Curve (ft.)	4	4	6	6
Weight (lbs.)	505	569	611	643
Standard Beam Flange Adj. Range (in.)	4.00-6.25	4.00-6.25	4.00-6.25	4.00-6.25
Trolley Speed (ft./min)				
Standard Single Speed	50	50	50	50
Lifting Speeds	31	21	13	10/9

**Dimensions listed are for minimum size "S" beam.

⚠ WARNING

Failure to properly install, operate and maintain the Lodestar Air XL Hoist may result in injury and/or property damage.

TO AVOID INJURY:

- Installation, maintenance and operation must be carried out as instructed in the manual provided with the Lodestar Air XL Hoist.
- Do not use the Lodestar Air XL Hoist for lifting people; special equipment is required for this purpose. Refer to ASME/ANSI A-17 Series and applicable state and local codes for specific requirements.

ShopAir™ chain hoist

**Compact, powerful, and precise
for assembly and manufacturing
applications up to 1,000 pounds.**

The CM ShopAir combines superior lifting speeds, rugged design, and precise load spotting in a portable air chain hoist. As a workstation hoist or a production line hoist, the ShopAir is the ideal choice.

CAPACITIES: 250 to 1,000 Lbs.

**NORMAL
OPERATING
PRESSURE:** 90 PSI (6.2 bar)

**AIR
CONSUMPTION:** 34 cu.feet/min.

- Standard Protector™ overload device.
- 10-pocket, oblique lay liftwheel provides longer chain life.
- Epoxy powder coat finish provides a durable exterior.
- Durable reduction gearing means reliable operation
- Variable flow, two lever pendant for precise load spotting.
- Threaded external exhaust for piping away exhaust in clean room or painting applications.
- Small, compact design for commercial & industrial applications.
- Industrial duty air motor for tough applications.
- Gear train is lifetime lubricated with non-oxidizing grease.
- Hardened forged steel, latch-type lower hook rotates 360°.
- Hardened forged steel, rigid latch-type upper hook.
- Rugged cast aluminum alloy hoist frame.
- Alloy load chain.
- Maximum pendant drop - 36 ft.
- Lifetime warranty against defects in materials and workmanship.
- Made in U.S.A.



ShopAir™ air chain hoist

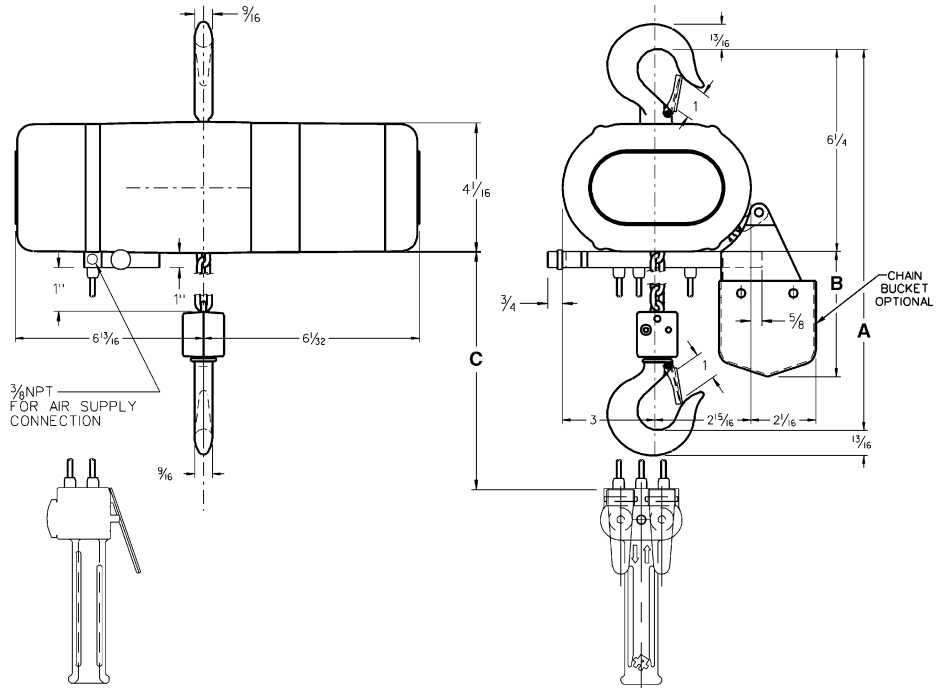

Specifications

Product code	Cap. (lbs.)	(in.)			Number of load chains	Speed FPM (under full load)		Shipping weight (lbs.)
		A	B	*C		lifting	lowering	
2178	250	10 ⁷ / ₈	3 ⁷ / ₈	6' 4"	1	31	83	30
2180	300	10 ⁷ / ₈	3 ⁷ / ₈	6' 4"	1	31	83	30
2182	500	10 ⁷ / ₈	3 ⁷ / ₈	6' 4"	1	21	75	30
2179	500	11 ¹⁵ / ₁₆	5 ³ / ₄	6' 4"	2	16	42	34
2181	600	11 ¹⁵ / ₁₆	5 ³ / ₄	6' 4"	2	16	42	34
2183	1,000	11 ¹⁵ / ₁₆	5 ³ / ₄	6' 4"	2	11	38	34

300 Lb. model shown with optional chain container

*WARNING

Overloading and improper use can result in injury.

To avoid injury:

- Do not exceed working load limit, load rating capacity
- Do not use to lift people or loads over people.
- use only alloy chain for overhead lifting.
- Read and follow all instructions.

AirStar chain hoist

The CM AirStar now boasts a longer service life and superior air leak protection. Design enhancements, including upgrades to the control manifold and air seals, give the AirStar best-in-class performance even for the most demanding applications.

With capacities from 1/4 to 1 Ton, this variable speed air chain hoist is compact, lightweight and ideal for heavy duty industrial and workstation duties.

CAPACITIES & LIFT

Capacities from 1/4 to 1 Ton. Metric Rated. 10 feet standard lift. Other lifts available.

LOW OPERATING COSTS

Air consumption rate is just 48 CFM, which means lower operating costs.

FAST LIFTING SPEEDS

As fast as 45 FPM lifting and 120 FPM lowering on the 1/2 Ton unit.

PORTABLE & RUGGED

Aluminum frame and end-cover makes it lightweight and a rugged design.

BUILT TO LAST

Hoistaloy® load chain for heavy duty, or stainless steel chain for spark resistant and medium duty loads.

SECURE & RELIABLE

Positive action, heavy-duty shoe type brake that stops and holds the load. Limit stops prevent over-travel when lifting and lowering.

EASY TO HANDLE

Inlet air swivel with built-in strainer provides free hoist movement.

EXTERNAL BRAKE ADJUSTMENT

Allows for quick adjustment of brake responsiveness and sensitivity for exceptional load positioning and control.

SMOOTH OPERATION

Multi-vane rotary air motor for high torque and smooth operation.

Equa-torque gearing (heat treated alloy steel spur gears) are accurately machined to provide a close meshed, compact gear reduction.

PENDANT THROTTLE OR PULL CORD CONTROL

Ergonomic pendant throttle control features fast pendant-to-hook reaction time and one-handed operation.

SPECIAL APPLICATIONS

Tapped exhaust port (1/2 NPTF) for cleanroom applications or add a supplemental muffler for even quieter operation.

METAL CHAIN CONTAINER STANDARD

FLEXIBILITY

Hook or lug suspension available.

SPARK-RESISTANT

Spark resistant models available for hazardous environments.



AirStar with hook suspension-Specifications

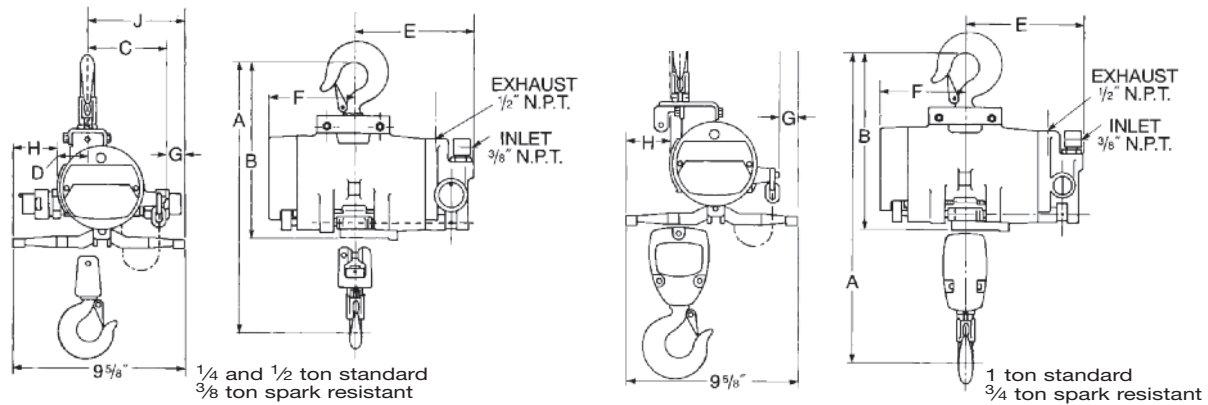

Clearance dimensions (in.)

Rated capacity* (tons)	Product code	A	B	C	D	E	F	G	H	J
1/4	7400A	15 1/4	10 1/4	4 3/4	1 3/4	7 1/16	5 1/16	15/16	2 3/16	5 11/16
1/4	7400B	15 1/4	10 1/4	4 3/4	1 3/4	7 1/16	5 1/16	15/16	2 3/16	5 11/16
1/4	7400C	15 1/4	10 1/4	4 3/4	1 3/4	7 1/16	5 1/16	15/16	2 3/16	5 11/16
1/4	7400D	15 1/4	10 1/4	4 3/4	1 3/4	7 1/16	5 1/16	15/16	2 3/16	5 11/16
1/2	7401A	15 1/4	10 1/4	4 3/4	1 3/4	7 1/16	5 1/16	15/16	2 3/16	5 11/16
1/2	7401B	15 1/4	10 1/4	4 3/4	1 3/4	7 1/16	5 1/16	15/16	2 3/16	5 11/16
1/2	7401C	15 1/4	10 1/4	4 3/4	1 3/4	7 1/16	5 1/16	15/16	2 3/16	5 11/16
1/2	7401D	15 1/4	10 1/4	4 3/4	1 3/4	7 1/16	5 1/16	15/16	2 3/16	5 11/16
3/8	7403A	15 1/4	10 1/4	4 3/4	1 3/4	7 1/16	5 1/16	15/16	2 3/16	5 11/16
3/8	7403B	15 1/4	10 1/4	4 3/4	1 3/4	7 1/16	5 1/16	15/16	2 3/16	5 11/16
1	7402A	18	10 1/4	5 3/4	3/4	7 1/16	5 1/16	15/16	2 3/16	6 11/16
1	7402B	18	10 1/4	5 3/4	3/4	7 1/16	5 1/16	15/16	2 3/16	6 11/16
1	7402C	18	10 1/4	5 3/4	3/4	7 1/16	5 1/16	15/16	2 3/16	6 11/16
1	7402D	18	10 1/4	5 3/4	3/4	7 1/16	5 1/16	15/16	2 3/16	6 11/16
3/4	7404A	18	10 1/4	5 3/4	3/4	7 1/16	5 1/16	15/16	2 3/16	6 11/16
3/4	7404B	18	10 1/4	5 3/4	3/4	7 1/16	5 1/16	15/16	2 3/16	6 11/16

Specifications

Type	Rated capacity* (tons)	Pull cord control		Pendant throttle control**		Reeving	Lifting speed max.† (F.P.M.)	Lowering speed max.† (F.P.M.)
		Product code no.	Net wt. (lbs.)	Product code no.	Net wt. (lbs.)			
Standard models								
Roller chain	1/4	7400A	37	7400B	47	1	65	95
	1/2	7401A	37	7401B	47	1	45	120
	1	7402A	51	7402B	61	2	23	60
Link chain	1/4	7400C	36	7400D	46	1	65	95
	1/2	7401C	36	7401D	46	1	45	120
	1	7402C	49	7402D	59	2	23	60
Spark resistant models								
Link chain	3/8	7403A	36	7403B	46	1	60	100
	3/4	7404A	49	7404B	59	2	29	52

**Equipped with 6 ft. pendant control.

† Speeds based on 90 PSI line pressure and with full rated hoist load.

Hoist speeds are adjustable and can be reduced to 50% of full rated speed. Shipped from factory with hoisting speed set at maximum rated speed; lowering speed set at reduced speed.

Standard lift 10 feet. Longer lifts available.

AirStar with lug suspension-Specifications

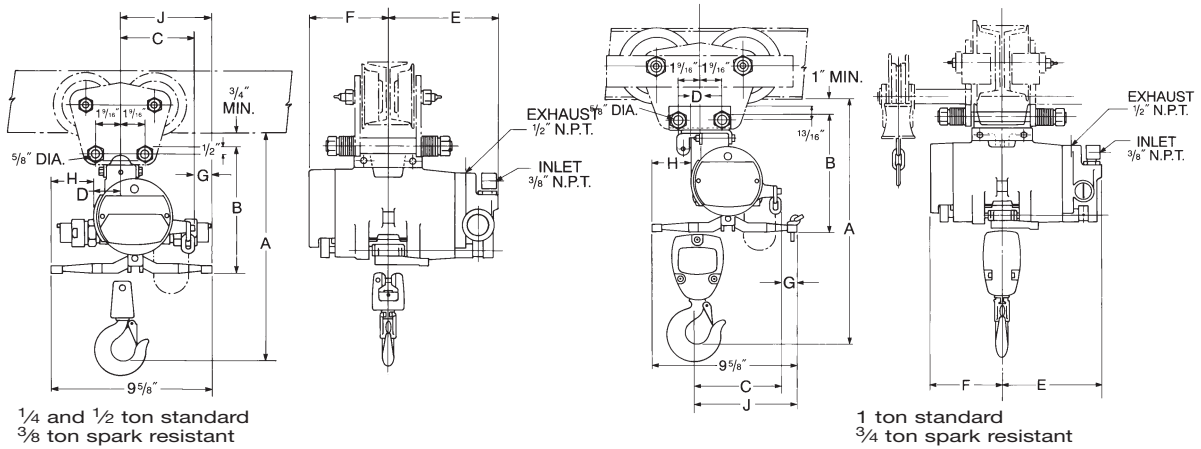

Clearance dimensions (in.)

Rated capacity* (tons)	Product code	A	B	C	D	E	F	G	H	J
1/4	7400F	13 7/8	8 1/8	4 3/4	1 3/4	7 1/16	5 1/16	15/16	2 3/16	5 11/16
1/4	7400G	13 7/8	8 1/8	4 3/4	1 3/4	7 1/16	5 1/16	15/16	2 3/16	5 11/16
1/2	7401F	13 7/8	8 1/8	4 3/4	1 3/4	7 1/16	5 1/16	15/16	2 3/16	5 11/16
1/2	7401G	13 7/8	8 1/8	4 3/4	1 3/4	7 1/16	5 1/16	15/16	2 3/16	5 11/16
3/8	7403C	13 7/8	8 1/8	4 3/4	1 3/4	7 1/16	5 1/16	15/16	2 3/16	5 11/16
3/8	7403D	13 7/8	8 1/8	4 3/4	1 3/4	7 1/16	5 1/16	15/16	2 3/16	5 11/16
1	7402F	17	8 1/4	5 3/4	3/4	7 1/16	5 1/16	15/16	2 3/16	6 11/16
1	7402G	17	8 1/4	5 3/4	3/4	7 1/16	5 1/16	15/16	2 3/16	6 11/16
3/4	7404C	17	8 1/4	5 3/4	3/4	7 1/16	5 1/16	15/16	2 3/16	6 11/16
3/4	7404D	17	8 1/4	5 3/4	3/4	7 1/16	5 1/16	15/16	2 3/16	6 11/16

Specifications

Type	Rated capacity* (tons)	Pull cord control		Pendant throttle control**		Reeving	Lifting speed max.† (F.P.M.)	Lowering speed max.† (F.P.M.)
		Product code no.	Net wt. (lbs.)	Product code no.	Net wt. (lbs.)			
Standard models								
Link chain	1/4	7400F	36	7400G	46	1	65	95
	1/2	7401F	36	7401G	46	1	45	120
	1	7402F	49	7402G	59	2	23	60
Spark resistant models								
Link chain	3/8	7403C	36	7403D	46	1	60	100
	3/4	7404C	49	7404D	59	2	29	52

**Equipped with 6 ft. pendant control.

† Speeds based on 90 PSI line pressure and with full rated hoist load.

Hoist speeds are adjustable and can be reduced to 50% of full rated speed. Shipped from factory with hoisting speed set at maximum rated speed; lowering speed set at reduced speed.

Standard lift 10 feet. Longer lifts available.

Spark Resistant Models

Spark resistant models offer maximum protection in hazardous environments. Components for spark resistance include bronze alloy hooks, stainless steel hook latches, non-magnetic chrome-nickel stainless steel load chain, modified load sprocket, guide and stripper arrangement and lower blocks of stainless steel for the 3/8-ton single line model and anodized aluminum body on the 3/4-ton two part reeved model.

The spark resistant models have capacities derated. The stainless steel load chain is lower strength and not as hard as the standard alloy steel load chain, thereby requiring reduced capacity ratings on these models.

Warning: The equipment illustrated here is not designed or suitable as a power source for lifting or lowering persons. Exceeding rated capacity is dangerous and can result in injury to persons and damage property.

AirStar 6 air hoist

Designed for general industrial applications where variable speed pneumatic power is preferable. Rated for loads of up to 3 tons. This compact, lightweight hoist features:

- Hoist alloy load chain for heavy duty or stainless steel chain for spark resistant, medium duty loads
- Lightweight aluminum frame and cover
- Positive action, spring biased Weston-type load brake holds the load, provides exacting load spotting and control
- Multi-vane rotary air motor with eight vanes for high torque, smooth operation, positive starting
- Precision cut heat treated helical and spur gear combination for quiet, efficient operation
- Pendant throttle handle is full flow design for precision throttle capabilities
- Spark resistant models available for hazardous environments
- Hook or lug suspension available
- Standard overload protector device
- Internal Muffler—reduces sound level
- Throttle Valve—precision throttle valves meter the air for smooth operation
- Chain container optional
- Lifetime warranty
- Metric rated
- Made in U.S.A.

Basic Hoist Data

Rated Loads: 1, 2, and 3-ton (Spark resistant models are rated at 1/2, 1 and 2 ton)

Air Pressure

Recommended: 90 PSI

Air Consumption: 70 SCFM (full load-full speed) slow speed model 80 SCFM (full load-full speed) fast speed model

Pendant Control Hose: 6 foot pendant hose standard for 10 foot lift hoist, longer hose assemblies up to 36 foot available.

Lift: 10 foot lifts are standard. Longer lifts are an optional extra.

Net Wt. (Basic Hoist): 100 pounds

Suspension: Hook or lug

Air Inlet Size: 3/4 NPTF

Air Supply Hose Size: 3/4 I.D. min.



AirStar 6 with lug suspension

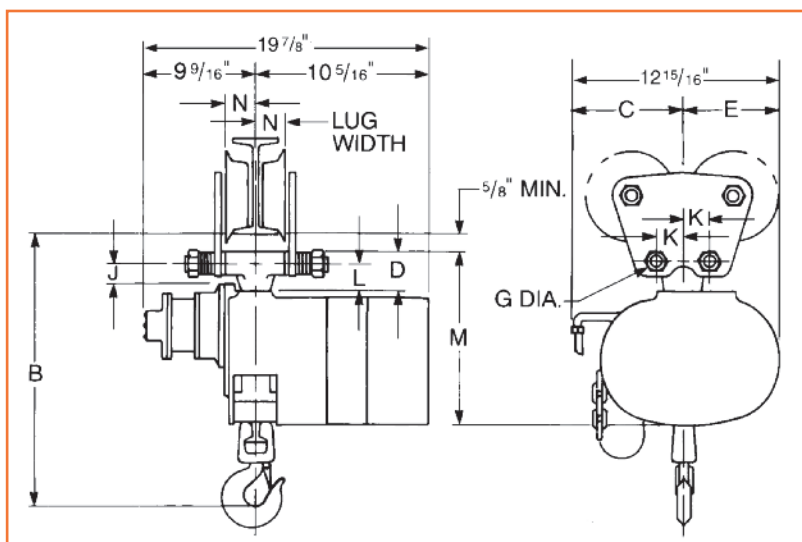

Clearance dimensions (in.)

Rated capacity* (tons)	Product code	B	C	D	E	J	K	L	M	N	G
1/2	7408B	16 1/4	6 3/4	2	6 3/16	7/8	1 9/16	1 5/16	9 15/16	1 13/16	5/8
1	7405C	16 1/16	6 3/4	2	6 3/16	7/8	1 9/16	1 5/16	9 15/16	1 13/16	5/8
1	7405D	16 1/16	6 3/4	2	6 3/16	7/8	1 9/16	1 5/16	9 15/16	1 13/16	5/8
1	7409B	21 3/8	8 1/16	2 13/16	4 7/8	1 1/2	2 1/2	1 15/16	10 11/16	2 3/16	1
2	7406C	19 3/4	8 1/16	2 13/16	4 7/8	1 1/2	2 1/2	1 15/16	10 11/16	2 3/16	1
2	7406D	19 3/4	8 1/16	2 13/16	4 7/8	1 1/2	2 1/2	1 15/16	10 11/16	2 3/16	1
2	7410B	25	5 13/16	4 5/8	7 1/8	2 15/16	3	3 3/8	12 7/8	3	1 1/4
3	7407C	23 3/4	5 13/16	4 5/8	7 1/8	2 15/16	3	3 3/8	12 7/8	3	1 1/4
3	7407D	23 3/4	5 13/16	4 5/8	7 1/8	2 15/16	3	3 3/8	12 7/8	3	1 1/4

Specifications

Model	Rated capacity* (tons)	Product code	Reeving	Full load hoist speed** (F.P.M.)	Full load lowering speed** (F.P.M.)	Approx. net weight (lbs.)
Standard model	1	7405C	1	13	18	106
	1	7405D	1	30	42	108
	2	7406C	2	6	9	116
	2	7406D	2	15	21	118
	3	7407C	3	4	6	164
	3	7407D	3	10	14	166
Spark resistant model	1/2	7408B	1	16	22	110
	1	7409B	2	8	11	120
	2	7410B	3	5	7	170

**Hoist speeds based on 90 PSI line pressure with full load at full throttle.

AirStar 6 with hook suspension-Specifications

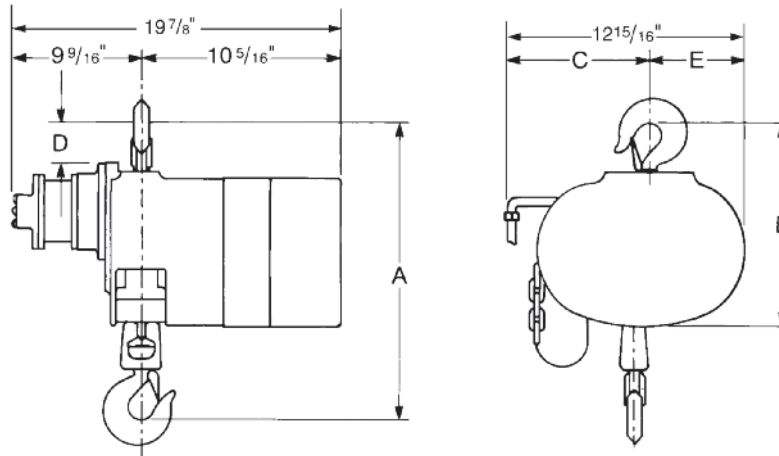

MODEL TMM-140

Clearance dimensions (in.)

Rated capacity* (tons)	Product code	A	B	C	D	E
1/2	7408A	16 3/4	11 1/16	6 3/4	2 11/16	6 3/16
1	7405A	16 3/4	11 1/16	6 3/4	2 11/16	6 3/16
1	7405B	16 3/4	11 1/16	6 3/4	2 11/16	6 3/16
1	7409A	22 7/8	12 13/16	8 1/16	4 7/16	4 7/8
2	7406A	22 7/8	12 13/16	8 1/16	4 7/16	4 7/8
2	7406B	22 7/8	12 13/16	8 1/16	4 7/16	4 7/8
2	7410A	25 7/8	14 3/8	5 13/16	5 5/8	7 1/8
3	7407A	25 7/8	14 3/8	5 13/16	5 5/8	7 1/8
3	7407B	25 7/8	14 3/8	5 13/16	5 5/8	7 1/8

Specifications

Model	Rated capacity* (tons)	Product code	Reeving	Full load hoist speed** (F.P.M.)	Full load lowering speed** (F.P.M.)	Approximate net weight (lbs.)
Standard model	1	7405A	1	13	18	93
	1	7405B	1	30	42	95
	2	7406A	2	6	9	110
	2	7406B	2	15	21	112
	3	7407A	3	4	6	144
	3	7407B	3	10	14	146
Spark resistant model	1/2	7408A	1	16	22	95
	1	7409A	2	8	11	112
	2	7410A	3	5	7	146

**Hoist speeds based on 90 PSI line pressure with full load at full throttle.

TMM-140 Air Manipulator Hoist

300 Lb./140Kg Air Manipulator Hoist

The CM TMM-140 is ideal for workstation applications. Lightweight and portable, the unit weighs less than 20 pounds and operates at 100% (A5) duty cycle.

- **Smooth operator** - Efficient rotary vane motor provides high uniform torque for quick response, and smooth, quiet operation.
- **Easy to use** - Handle-mounted pendant control for one-handed operation and load positioning.
- **Variable speeds** - Precise and infinite speed control for accurate load spotting.
- **Wire rope design** - Self-winding lifting cable stores conveniently inside unit.
- **Suspension** - Swivel top and bottom hooks with hook latches standard, for portability and quick installation.
- **Disc brake** - Secures load and eliminates drift when pendant is released.
- **Note** - A 3/8" NPT air filter-regulator-lubricator is needed for effective operation. Spark resistant features are not available.

Ideal Applications Include:

- Assembly lines
- Machine shops
- Cleaning and/or dipping operations
- Manufacturing plants
- Power generating stations
- Shipping departments
- Chemical facilities
- Fabricating shops
- Repetitive lifting applications
- Auto and truck repair
- Handling fixtures and dies

***WARNING**

Overloading and improper use can result in injury.

To avoid injury:

- Do not exceed working load limit, load rating capacity
- Do not use to lift people or loads over people.
- use only alloy chain for overhead lifting.
- Read and follow all instructions.

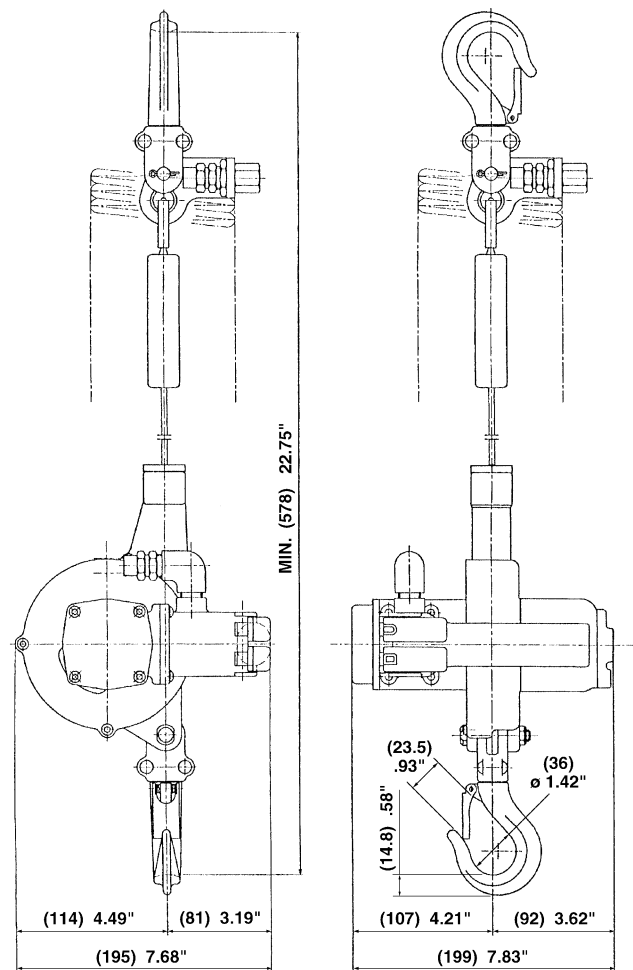

Specifications:

Capacity (lb.)	Model number	Product code	Std. lift (ft.)	Lift speeds (FPM)				Air consumption		Headroom (in.)	Housing dimen. (in.)			Max air pres. (psi)	Net wt. (lb.)
				Load (up)	(Down)	No load (up)	(Down)	(m ³ /min)	(ft ³ /min)		D	W	L		
300	TMM-140	17050W	6' 6"	36	59	49	39	0.6	2½	22¾	7⅔	7⅞	23¾	70-95	18.7

NOTE: Dimensions in parenthesis are in millimeters, other dimensions in inches. Top and bottom hook dimensions are the same.

Hurricane 360° hand chain hoist

For the ultimate flexibility in a hand chain hoist, the CM Hurricane 360° is the choice for a wide range of applications. The patented hand chain cover rotates a full 360 degrees to allow loads to be lifted, pulled, or positioned from virtually any angle.

- **Standard Load Limiter** - For simple, automatic overload protection.
- **Braking Power** - Weston-Style braking system provides reliable positive load control.
- **Powder Coated Finish** - For corrosion protection.
- **Heat Treated Steel Gearing** - All internal gears & pinions are heat treated steel for high strength and long life.
- **Chain Guide & Stripper** - Assures load chain alignment.
- **Precision 4-Pocket Liftwheel** - Fully machined for better chain fit and reduced wear allowing for accurate movement of the load chain.
- **Hardened Steel Chain** - Alloy steel load chain assures high strength and long wear life.
- **Minimal Maintenance** - Easily disassembled, requiring no special tools.
- **Meets ASME B30.16** - And European CE Standard
- **5-Year Warranty** - Against defects in materials and workmanship.
- **Fast & Easy Parts Access** - Genuine CM Hurricane 360° parts are available in Total Repair Kits and convenient bulk packaging.



**Sealed Ball Bearings
and Sliding Bushings**

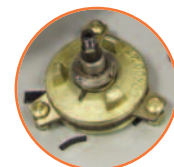

**Weston-Style
Brake System**

***WARNING**

Overloading and improper use can result in injury.

To avoid injury:

- Do not exceed working load limit, load rating capacity
- Do not use to lift people or loads over people.
- use only alloy chain for overhead lifting.
- Read and follow all instructions.



Cyclone hand chain hoist

One of the most popular and reliable hoists ever designed.

- Most interchangeability of parts in the industry
- Standard Load Limiter for simple, automatic overload protection
- Enclosed contoured Weston-type automatic brake for positive load control
- High-efficiency spur gearing for greater lift with minimum effort
- Rugged Hoistaloy chain for added strength and durability
- Fully machined, forged liftwheel pockets for easier lifting and smooth free chaining
- High-strength aluminum alloy castings in frame and covers
- Inspected over 75 times to meet or exceed HMI and ASME/ANSI performance and safety standards
- Standard hand chain drop is 2 feet less than lift, (example: 8 foot lift hoist has 6 foot hand chain drop)
- Lifetime warranty
- Metric rated
- Made in U.S.A.

Options Include:

- Fabric chain bags
- Metal chain containers
- Zinc-plated load and hand chain
- Unwelded hand chain
- Latchlok hooks
- Bronze hooks
- Bullard hooks
- Eye-type suspension



***WARNING**

Overloading and improper use can result in injury.

To avoid injury:

- Do not exceed working load limit, load rating capacity
- Do not use to lift people or loads over people.
- Use only alloy chain for overhead lifting.
- Read and follow all instructions.

The Cyclone combines superior engineering, efficiency and durability. Available in a variety of capacities from 1/4 ton to 10 tons.



Cyclone hand chain hoist

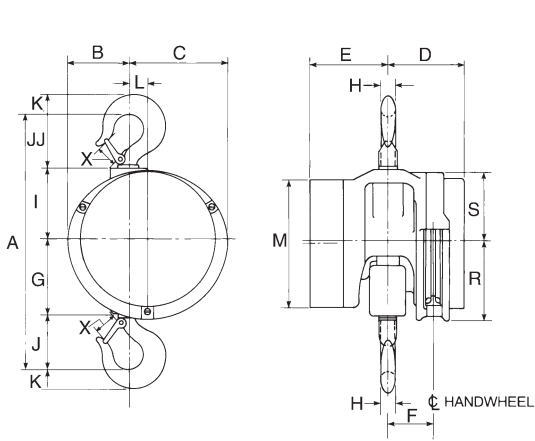

1/4 - 2 ton

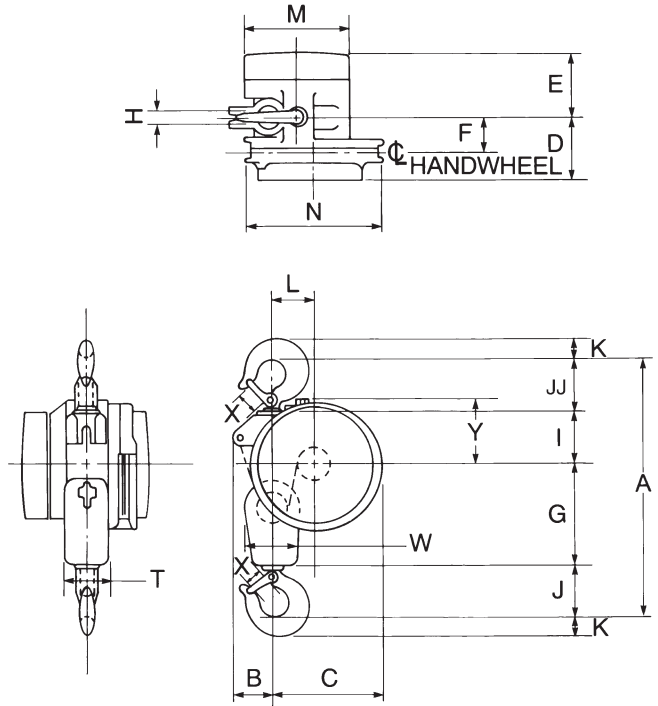

3 - 4 ton

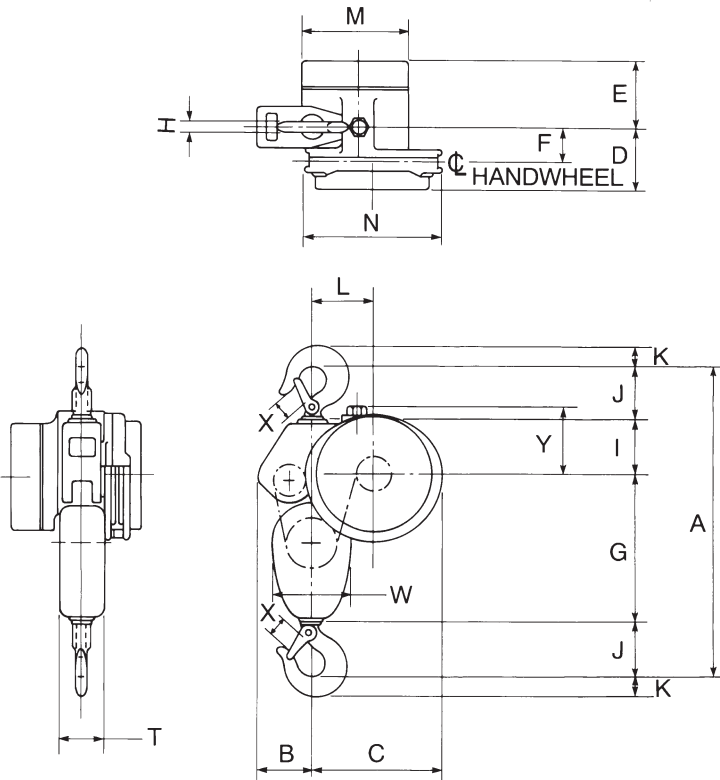

5 - 6 ton

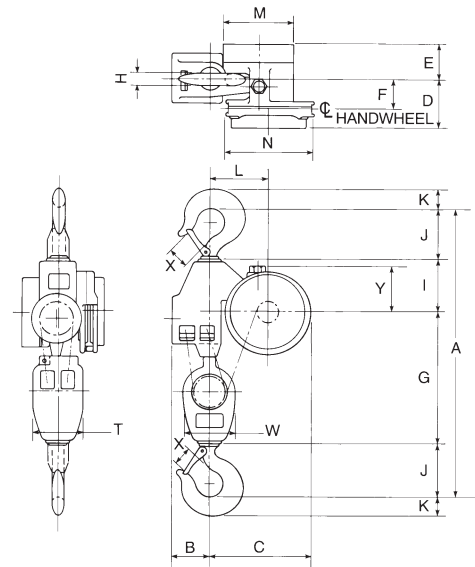

8 - 10 ton

Cyclone hand chain hoist-Specifications

Specifications

Rated capacity* (tons)	Product code	Standard lift† (ft.)	Reeving	Minimum distance between hooks (in.)	Chain overhauled to lift load one foot (ft.)	Chain pull to lift full load (lbs.)	Shipping weight (lbs.)
1/4	4621	10	1	12 ⁷ / ₈	22 ¹ / ₂	23	40
1/2	4622	10	1	12 ⁷ / ₈	22 ¹ / ₂	46	40
1	4624	10	1	14	30	69	43
1 1/2	4625	10	1	17 ⁵ / ₁₆	40 ¹ / ₂	80	69
2	4626	10	1	17 ⁵ / ₁₆	52	83	68
3	4627	10	2	21 ¹ / ₂	81	85	103
4	4628	10	2	21 ¹ / ₂	104	88	103
5	4629	10	3	24 ¹ / ₄	156	75	138
6	4630	10	3	25 ¹ / ₄	156	90	142
8	4631	10	4	34 ¹ / ₂	208	89	247
10	4632	10	5	35 ¹ / ₂	260	95	250

† Can be supplied with longer lifts

Clearance dimensions (in.)

Dimension	Rated capacity*(tons)								
	1/4	1/2	1	1 1/2 & 2	3 & 4	5	6	8	10
A	12 ⁷ / ₈	12 ⁷ / ₈	14	17 ⁵ / ₁₆	21 ¹ / ₂	24 ¹ / ₄	25 ¹ / ₄	34 ¹ / ₂	35 ¹ / ₂
B	3 ¹¹ / ₁₆	3 ¹¹ / ₁₆	3 ¹ / ₄	4 ³ / ₁₆	3 ⁵ / ₁₆	4 ³ / ₁₆	4 ³ / ₁₆	4 ³ / ₄	4 ³ / ₄
C	7 ³ / ₁₆	7 ³ / ₁₆	7 ³ / ₁₆	6 ¹¹ / ₁₆	8 ¹⁵ / ₁₆	10 ⁵ / ₁₆	10 ⁵ / ₁₆	12 ³ / ₄	12 ³ / ₄
D	4 ¹ / ₈	4 ¹ / ₈	4 ¹ / ₈	5 ¹ / ₁₆	5 ¹ / ₁₆	4 ⁷ / ₈	4 ⁷ / ₈	5 ¹³ / ₁₆	5 ¹³ / ₁₆
E	3 ¹ / ₄	3 ¹ / ₄	3 ¹ / ₄	4 ¹³ / ₁₆	4 ¹³ / ₁₆	5	5	4 ¹ / ₁₆	4 ¹ / ₁₆
F	2 ¹ / ₁₆	2 ¹ / ₁₆	2 ¹ / ₁₆	3 ¹ / ₈	3	2 ¹⁵ / ₁₆	2 ¹⁵ / ₁₆	3 ³ / ₄	3 ³ / ₄
G	3 ⁷ / ₈	3 ⁷ / ₈	3 ³ / ₄	5 ³ / ₁₆	8 ¹ / ₄	11 ¹³ / ₁₆	11 ¹³ / ₁₆	17 ³ / ₁₆	17 ³ / ₁₆
H	1 ¹ / ₁₆	1 ¹ / ₁₆	1 ³ / ₁₆	1 ¹ / ₈	1 ¹ / ₄	1 ¹ / ₄	1 ³ / ₈	1 ¹¹ / ₁₆	1 ¹³ / ₁₆
I	3 ³ / ₄	3 ³ / ₄	3 ³ / ₄	4 ¹³ / ₁₆	4 ¹ / ₄	4 ³ / ₁₆	4 ³ / ₁₆	6 ¹ / ₁₆	6 ¹ / ₁₆
J	2 ⁵ / ₈	2 ⁵ / ₈	2 ¹⁵ / ₁₆	3 ⁵ / ₈	4 ¹ / ₈	4 ¹ / ₈	4 ⁵ / ₈	5 ⁵ / ₈	6 ¹ / ₈
JJ	2 ⁵ / ₈	2 ⁵ / ₈	3 ⁹ / ₁₆	3 ¹¹ / ₁₆	4 ⁷ / ₈	—	—	—	—
K	1 ⁵ / ₁₆	1 ⁵ / ₁₆	1 ¹ / ₈	1 ¹ / ₂	1 ¹¹ / ₁₆	1 ¹¹ / ₁₆	1 ⁷ / ₈	2 ¹ / ₄	2 ⁹ / ₁₆
L	1 ³ / ₄	1 ³ / ₄	1 ³ / ₄	1 ¹ / ₄	3 ¹ / ₂	4 ⁷ / ₈	4 ⁷ / ₈	7 ⁵ / ₁₆	7 ⁵ / ₁₆
M	7 ¹ / ₁₆	7 ¹ / ₁₆	7 ¹ / ₁₆	8 ⁵ / ₈	8 ⁵ / ₈	8 ⁵ / ₈	8 ⁵ / ₈	8 ⁵ / ₈	8 ⁵ / ₈
N	—	—	—	—	10 ⁷ / ₈	10 ⁷ / ₈	10 ⁷ / ₈	10 ⁷ / ₈	10 ⁷ / ₈
R	5 ⁷ / ₁₆	5 ⁷ / ₁₆	5 ⁷ / ₁₆	5 ⁷ / ₁₆	—	—	—	—	—
S	4 ¹¹ / ₁₆	4 ¹¹ / ₁₆	4 ¹¹ / ₁₆	4 ¹¹ / ₁₆	—	—	—	—	—
T	—	—	—	—	3 ⁷ / ₈	4	4	6 ³ / ₈	6 ³ / ₈
W	—	—	—	—	4 ¹ / ₂	6 ¹ / ₄	6 ¹ / ₄	6 ⁷ / ₁₆	6 ⁷ / ₁₆
X	1 ¹ / ₃₂	1 ¹ / ₃₂	1 ¹ / ₈	1 ⁵ / ₁₆	1 ⁵ / ₈	1 ⁵ / ₈	1 ³ / ₄	2 ¹ / ₁₆	2 ⁵ / ₁₆
Y	—	—	—	—	5 ¹ / ₈	5 ⁷ / ₈	5 ⁷ / ₈	5 ⁹ / ₁₆	5 ⁹ / ₁₆

***⚠ WARNING**

Overloading and improper use can result in injury.

To avoid injury:

- Do not exceed working load limit, load rating capacity
- Do not use to lift people or loads over people.
- use only alloy chain for overhead lifting.
- Read and follow all instructions.

Cyclone Army type trolley hoist

Same quality and performance as the Cyclone in a compact, low headroom integral trolley mount. Ideal for applications requiring a moveable hoist including:

- Rugged steel loadbars connected directly to hoist frame
- Reduced headroom, side clearances and end approach for easy maneuvering of heavy loads in tight places
- Standard Load Limiter automatic overload protection
- Plain and geared trolley mounts in capacities from 1/4 to 12 tons
- Universal tread trolley wheels for operation on sloped or flat flanged beams
- Standard hand chain drop 2 feet less than lift (example: 8 foot lift hoist has 6 foot hand chain drop)
- Chain containers, zinc-plated load and hand chain, aluminum unwelded hand chain, Latchlok hooks, bronze hooks, bullard hooks, larger beam trolleys, trolley guards, and units without Load Limiter optional, depending on capacity
- Lifetime warranty
- Metric rated
- Made in U.S.A.



* ⚠ WARNING

Overloading and improper use can result in injury.

To avoid injury:

- Do not exceed working load limit, load rating capacity
- Do not use to lift people or loads over people.
- use only alloy chain for overhead lifting.
- Read and follow all instructions.

Specifications

Rated capacity* (tons)	Product code		Standard lift (ft.)	Reeving	American standard depth (in.)†	Beam adjustment ranges flange width (in.)†	Chain pull to lift capacity loads (lbs.)	Chain overhauled to lift load one foot (ft.)	Min. headroom (in.)	Min. radius curve (in.)	Shipping weight (lbs.)	
	Plain trolley	Geared trolley									Plain trolley	Geared trolley
1/4	4521	4541	10	1	4-12**	2 5/8-5 1/2	23	22 1/2	11 3/4	30	68	110
1/2	4522	4542	10	1	4-12**	2 5/8-5 1/2	46	22 1/2	11 3/4	30	68	110
1	4524	4544	10	1	4-12**	2 5/8-5 1/2	69	30	11 3/4	30	81	133
1 1/2	4525	4545	10	1	6-15	3 3/8-5 5/8	80	40 1/2	15 5/16	30	140	168
2	4526	4546	10	1	6-15	3 3/8-5 5/8	83	52	15 5/16	30	140	168
3	4527	4547	10	2	7-15	3 5/8-5 5/8	85	81	18 7/8	48	189	237
4	4528	4548	10	2	7-15	3 5/8-5 5/8	87	104	18 7/8	48	189	237
5	4529	4549	10	3	8-18	4-6 1/4	74	156	23 1/2	60	278	310
6	4530	4550	10	3	8-18	4-6 1/4	89	156	24	60	283	315
8	4531	4551	10	4	12-24	5-8	91	208	28 1/4	72	526	601
10	4532	4552	10	5	12-24	5-8	93	260	28 1/4	72	535	611
12	4533	4553	10	6	15-24	5 1/2-8	95	312	30 3/8	96	1068	1098

** For 1/4 through 1 ton geared trolleys - minimum beam size S6 x 12.5 (3 3/8 flange width)

† Universal tread track wheels designed to operate on either sloped or flat flange beam, rails or tracks

Cyclone Army type trolley hoist-Specifications

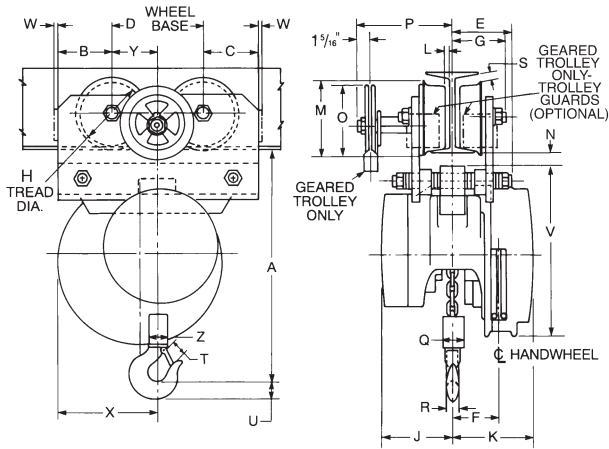

1/4-6 TON

1/4 - 6 ton

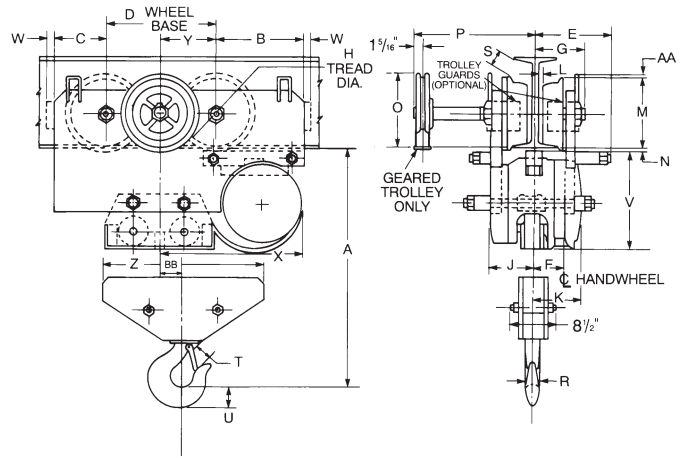

8 - 12 ton

Clearance dimensions (in.)

Dimension	Rated capacity* (tons)															
	1/4, 1/2 & 1		1 1/2 & 2		3 & 4		5		6		8		10		12	
	Plain	Geared	Plain	Geared	Plain	Geared	Plain	Geared	Plain	Geared	Plain	Geared	Plain	Geared	Plain	Geared
A	11 3/4	11 13/16	15 5/16	15 5/16	18 7/8	18 7/8	23 1/2	23 1/2	24	24	28 1/4	28 1/4	28 1/4	28 1/4	30 3/8	30 3/8
B	4 3/16	4 3/8	3 1/16	3 1/16	5 3/4	5 3/4	6 1/2	6 1/2	6 1/2	6 1/2	8 15/16	8 15/16	8 15/16	8 15/16	10 7/8	10 7/8
C	2 9/16	2 9/16	3 1/16	3 1/16	3 7/16	3 7/16	3 3/4	3 3/4	3 3/4	3 3/4	5 1/4	5 1/4	5 1/4	5 1/4	7 3/16	7 3/16
D	6	6	6	6	6 7/8	6 7/8	7 3/4	7 3/4	7 3/4	7 3/4	11	11	11	11	11	11
E	4 1/2	4 15/16	5	5	5 7/16	5 7/16	6 1/8	6 1/8	6 1/8	6 1/8	7 1/4	7 1/4	7 1/4	7 1/4	7 1/4	7 1/4
F	2 1/16	2 1/16	3 1/8	3 1/8	3	3	2 13/16	2 13/16	2 13/16	2 13/16	3	3	3	3	3	3
G	3	3 3/4	3 5/8	3 3/4	4 5/16	4 5/16	4 15/16	4 15/16	4 15/16	4 15/16	5 9/16	5 9/16	5 9/16	5 9/16	5 13/16	5 13/16
H	3 1/8	4	4 3/4	4	5	5	6	6	6	6	8	8	8	8	8	8
J	3 1/4	3 1/4	4 13/16	4 13/16	4 13/16	4 13/16	5	5	5	5	4 13/16	4 13/16	4 13/16	4 13/16	4 13/16	4 13/16
K	4 1/8	4 1/8	5 1/16	5 1/16	5 1/16	5 1/16	4 7/8	4 7/8	4 7/8	4 7/8	5 1/16	5 1/16	5 1/16	5 1/16	5 1/16	5 1/16
L	5/16	5/16	1/2	5/16	1/4	1/4	3/8	3/8	3/8	3/8	1/2	1/2	1/2	1/2	1 1/16	1 1/16
M	4	4 3/4	5 9/16	4 3/4	5 7/8	5 7/8	7	7	7	7	9 7/16	9 7/16	9 7/16	9 7/16	9 1/2	9 1/2
N	1/2	9/16	9/16	9/16	1 1/16	1 1/16	1 1/16	1 1/16	1 1/16	1 1/16	1 1/2	1 1/2	1 1/2	1 1/2	7/16	7/16
O	-	5 9/16	-	5 9/16	6 1/8	6 1/8	6 3/4	6 3/4	6 3/4	6 3/4	7 9/16	7 9/16	7 9/16	7 9/16	7 3/16	7 3/16
P	-	10	-	10	8 15/16	8 15/16	10 7/16	10 7/16	10 7/16	10 7/16	11 7/16	11 7/16	11 7/16	11 7/16	11 11/16	11 11/16
Q	2	2	2 1/2	2 1/2	3 7/8	3 7/8	4	4	4	4	11 15/16	11 15/16	-	-	-	-
R	1 1/16	1 1/16	1 1/8	1 1/8	1 1/4	1 1/4	1 1/4	1 1/4	1 3/8	1 3/8	1 13/16	1 13/16	1 13/16	1 13/16	2 3/8	2 3/8
S	1/16	15/16	3/16	15/16	15/16	15/16	3/4	3/4	3/4	3/4	2 3/16	2 3/16	2 3/16	2 3/16	5 1/16	5 1/16
T	1	1	1 3/8	1 3/8	1 5/8	1 5/8	1 5/8	1 5/8	1 3/4	1 3/4	2 5/16	2 5/16	2 5/16	2 5/16	3	3
U	7/8	7/8	1 1/8	1 1/8	1 1/16	1 1/16	1 1/16	1 1/16	1 7/8	1 7/8	2 9/16	2 9/16	2 9/16	2 9/16	3	3
V	10 1/8	10 1/8	11 3/8	11 3/8	11 3/8	11 3/8	11 3/8	1 3/8	11 3/8	11 3/8	11 5/8	11 5/8	11 5/8	11 5/8	11 5/8	11 5/8
W	1/4	3/8	3/8	3/8	1/2	1/2	5/8	5/8	5/8	5/8	5/8	5/8	5/8	5/8	5/8	5/8
X	7 3/16	7 3/16	6 11/16	6 11/16	8 15/16	8 15/16	10 5/16	10 5/16	10 5/16	10 5/16	14 7/16	14 7/16	14 7/16	14 7/16	16 3/8	16 3/8
Y	3	3	3	3	3 7/16	3 7/16	3 7/8	3 7/8	3 7/8	3 7/8	5 1/2	5 1/2	5 1/2	5 1/2	5 1/2	5 1/2
Z	2	2	2 1/2	2 1/2	4 1/2	4 1/2	6 1/4	6 1/4	6 1/4	6 1/4	13 15/16	13 15/16	18 3/16	18 3/16	21 11/16	21 11/16
AA	-	-	-	-	-	-	-	-	-	-	3/8	3/8	3/8	3/8	3/8	3/8
BB	-	-	-	-	-	-	-	-	-	-	1 15/16	1 15/16	0	0	0	0

Note: Dimensions are based on minimum beam and may vary with larger beams.

Cyclone trolley hoist for low headroom

Cyclone and trolley all in one unit for low headroom applications features:

- Crowned tread and flanged wheels to minimize rolling friction
- Simple, efficient design
- Reduced headroom, side clearances and end approach for easy maneuvering of loads in tight places
- Plain trolley mounts in capacities from 1/2 to 6 tons
- Geared trolley mounts in capacities from 1 1/2 to 6 tons
- Standard hand chain drop 2 feet less than lift (example: 8 foot lift hoist has 6 foot hand chain drop)
- Chain containers, zinc-plated load and hand chain, aluminum unwelded hand chain, Latchlok hooks, bronze hooks, bullard hooks, larger beam trolleys, trolley guards and units without Load Limiter optional, depending on capacity
- Standard Load Limiter/automatic overload protection
- Lifetime warranty
- Metric rated
- Made in U.S.A.

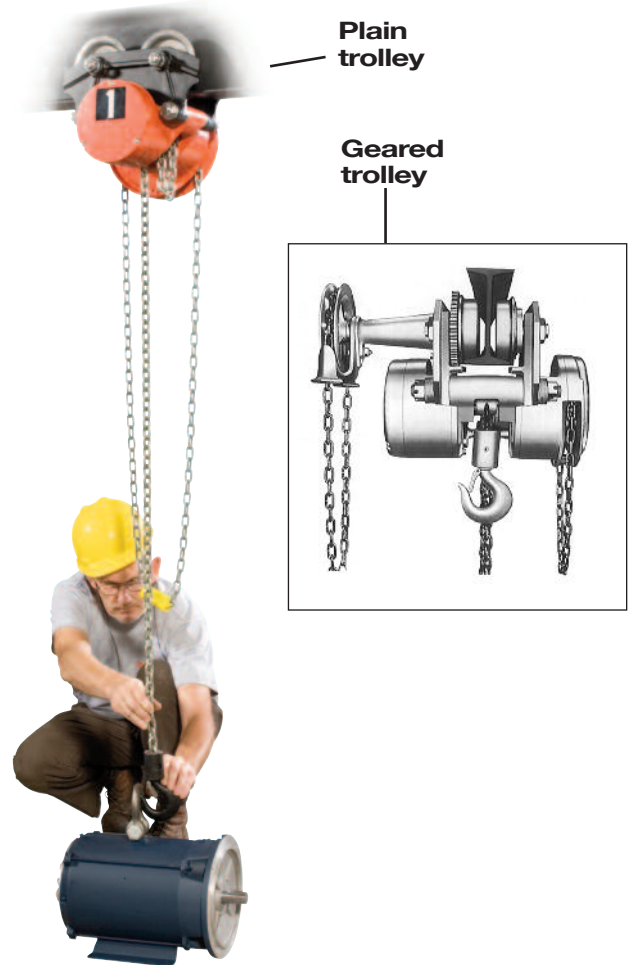

Specifications

Rated capacity* (tons)	Product code		Std. lift (ft.)	Reeving	American standard depth (in.)††	Beam adjustment ranges flange width (in.)††	Chain pull to lift full load (lbs.)	Chain overhauled to lift load one foot (ft.)	Min. headroom (in.)	Min. radius curve (in.)	Shipping weight (lbs.)	
	Plain trolley	Geared trolley									Plain trolley	Geared trolley
1/2	4832	—	10	1	6-12**†	3 ³ / ₈ -5	46	22 ¹ / ₂	8 ⁷ / ₈	36	91	—
1	4834	—	10	1	6-12**†	3 ³ / ₈ -5	69	30	9 ¹ / ₄	36	96	—
1 1/2	4835	4925	10	1	7-15**†	3 ⁵ / ₈ -5 ¹ / ₂	80	40 ¹ / ₂	12 ¹ / ₂	48	190	214
2	4836	4926	10	1	7-15†	3 ⁵ / ₈ -5 ¹ / ₂	83	52	12 ¹ / ₂	48	190	220
3	4837	4927	10	2	7-15†	3 ⁵ / ₈ -5 ¹ / ₂	85	81	14 ¹ / ₈	48	210	240
4	4838	4928	10	2	8-24†	4-7	88	104	16 ³ / ₄	96	315	379
5	4839	4929	10	3	8-24†	4-7	75	156	18 ¹ / ₄	96	338	360
6	4840	4930	10	3	8-24†	4-7	90	156	18 ³ / ₄	96	387	357

** 1/2 and 1 ton also available for 4" and 5" S-beam, and 1 1/2 and 2 ton for 6" S-beam without extra charge

† Universal tread trackwheels designed to operate on either sloped or flat flange beams, rails, or tracks Also can be used on flat flange beams within the same range of flange widths, provided beam depth will accommodate wheel diameter (check clearance diagram)

†† Applies to minimum size S-beam within adjustability range

*WARNING

Overloading and improper use can result in injury.

To avoid injury:

- Do not exceed working load limit, load rating capacity
- Do not use to lift people or loads over people.
- use only alloy chain for overhead lifting.
- Read and follow all instructions.

Cyclone trolley hoist for low headroom-Specifications

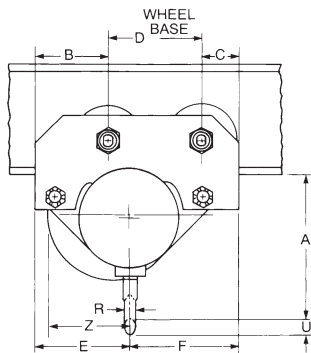

Plain trolley

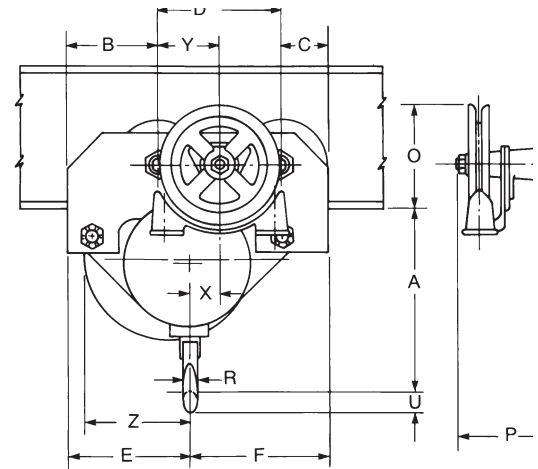
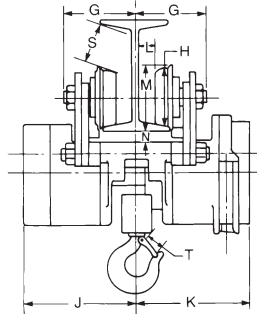

Geared trolley

Clearance dimensions (in.)

Dimension	Rated capacity* (tons)						
	1/2	1	1 1/2 & 2	3	4	5	6
A	8 7/8	9 1/4	12 1/2	14 1/8	16 3/4	18 1/4	18 3/4
B	3 5/8	3 5/8	6	6	7 3/8	7 3/8	7 3/8
C	3 5/8	3 5/8	3 1/8	3 1/8	4	4	4
D	6 1/2	6 1/2	7 3/4	7 3/4	9	9	9
E	6 7/8	6 3/4	7 5/8	10 1/2	11	11 7/8	11 7/8
F	6 3/4	6 7/8	9 1/4	6 3/8	9 3/8	8 1/2	8 1/2
G	3 3/4	3 3/4	5 1/8	5 1/8	5 7/8	5 7/8	5 7/8
H	4 3/4	4 3/4	4 5/8	4 5/8	5 7/8	5 7/8	5 7/8
J	6	6	9 5/16	9 5/16	10 9/16	10 9/16	10 9/16
K	8 1/8	8 1/8	9 5/8	9 5/8	11	11	11
L	1/2	1/2	1/2	1/2	1/2	1/2	1/2
M	5 7/16	5 7/16	5 3/8	5 3/8	6 3/4	6 3/4	6 3/4
N	1	1	1	1	1 1/8	1 1/8	1 1/8
O	—	—	6 3/4	6 3/4	6 1/2	6 1/2	6 1/2
P	—	—	4 7/8	4 7/8	4 1/4	4 1/4	4 1/4
R	1 1/16	1 3/16	1 1/8	1 1/4	1 1/4	1 1/4	1 3/8
S	5/16	5/16	1 3/8	1 3/8	1 1/16	1 1/16	1 1/16
T	1 1/32	1 1/8	1 5/16	1 5/8	1 5/8	1 5/8	1 3/4
U	1 5/16	1 1/8	1 1/2	1 11/16	1 11/16	1 11/16	1 7/8
W	—	—	5 5/8	5 5/8	7	7	7
X	—	—	2 1/4	5/8	7/8	—	—
Y	—	—	3 7/8	3 7/8	4 1/2	4 1/2	4 1/2
Z	7 3/8	7 1/4	6 5/8	9 1/2	9 1/2	10 3/8	10 3/8

Note: Dimensions G, L, M, O, P, S & W are shown for minimum S-beam and increase proportionally for larger beams. Dimension N is shown for minimum S-beam and decreases proportionally for larger beams.

Cyclone Fabric Chain Bags



Cyclone, Army type and low headroom trolley hoist optional fabric chain bags

Product code		Rated capacity* (tons)	Maximum length of lift (ft.)	Bag diameter (in.)	Bag length (in.)	Approx. weight (lbs.)
Cyclone and Army type	Low headroom trolley hoist					
2482	2493	1/4-1/2	18	7	7 1/2 x 7 1/2	3
2483	2488	1/4-1/2	18.1-36	10	7 1/2 x 7 1/2	3
2484	2495	1/4-1/2	36.1-54	13	7 1/2 x 7 1/2	3
2485	2496	1/4-1/2	54.1-78	16	7 1/2 x 7 1/2	4
2486	2497	1/4-1/2	78.1-93	18	7 1/2 x 7 1/2	4
2487	2498	1/4-1/2	93.1-129	20	7 1/2 x 7 1/2	4
2482	2493	1	11	7	7 1/2 x 7 1/2	3
2483	2494	1	11.1-24	10	7 1/2 x 7 1/2	3
2484	2495	1	24.1-37	13	7 1/2 x 7 1/2	3
2485	2496	1	37.1-55	16	7 1/2 x 7 1/2	4
2486	2497	1	55.1-66	18	7 1/2 x 7 1/2	4
2487	2498	1	66.1-92	20	7 1/2 x 7 1/2	4
2488	2488	1 1/2-2	13	10	7 1/2 x 7 1/2	3
2489	2489	1 1/2-2	13.1-20	13	7 1/2 x 7 1/2	3
2490	2490	1 1/2-2	20.1-29	16	7 1/2 x 7 1/2	4
2491	2491	1 1/2-2	29.1-35	18	7 1/2 x 7 1/2	4
2492	2492	1 1/2-2	35.1-49	20	7 1/2 x 7 1/2	4
2489	2489	3-4	10	13	7 1/2 x 7 1/2	3
2490	2490	3-4	10.1-15	16	7 1/2 x 7 1/2	4
2491	2491	3-4	15.1-18	18	7 1/2 x 7 1/2	4
2492	2492	3-4	18.1-25	20	7 1/2 x 7 1/2	4
2490	2490	5-6	10	16	7 1/2 x 7 1/2	4
2491	2491	5-6	10.2-12	18	7 1/2 x 7 1/2	4
2492	2492	5-6	12.1-17	20	7 1/2 x 7 1/2	4
2491	2491	8	8	18	7 1/2 x 7 1/2	4
2492	2492	8	8.1-12	20	7 1/2 x 7 1/2	4
2492	2492	10	10	20	7 1/2 x 7 1/2	4



Cyclone Chain Containers

Cyclone, Army type and low headroom trolley hoist optional metal chain containers

Product code		Rated capacity* (tons)	Maximum length of lift (ft.)	Bucket length (in.)	Bucket diameter (in.)	Approximate weight (lbs.)
Cyclone and Army type	Low headroom trolley hoist					
4603S-373S	4614S-329S	1/4-1/2	9	8	5	3
4603S-373S	4614S-330S	1/4-1/2	9.1-18	11	5	4
4603S-375S	4614S-331S	1/4-1/2	18.1-27	14	5	4
4603S-376S	4614S-332S	1/4-1/2	27.1-36	17	5	5
4603S-377S	4614S-333S	1/4-1/2	45	20	5	6
4603S-378S	4614S-334S	1/4-1/2	45.1-54	23	5	6
4603S-379S	4614S-335S	1/4-1/2	54.1-78	31	5	8
4603S-380S	4614S-336S	1/4-1/2	78.1-93	36	5	9
4603S-381S	4614S-337S	1/4-1/2	93.1-129	48	5	12
4063S-382S	4614S-339S	1	11	11	5	4
4603S-383S	4614S-340S	1	11.1-18	14	5	4
4603S-384S	4614S-341S	1	18.1-24	17	5	5
4603S-385S	4614S-342S	1	24.1-31	20	5	6
4603S-386S	4614S-343S	1	31.1-37	23	5	6
4603S-387S	4614S-344S	1	37.1-55	31	5	8
4603S-388S	4614S-345S	1	55.1-66	36	5	9
4603S-389S	4614S-346S	1	66.1-92	48	5	12
4603S-352S	4614S-352S	1 1/2-2	9	14	5	4
4603S-353S	4614S-353S	1 1/2-2	9.1-13	17	5	5
4603S-354S	4614S-354S	1 1/2-2	13.1-16	20	5	6
4603S-355S	4614S-355S	1 1/2-2	16.1-20	23	5	6
4603S-356S	4614S-356S	1 1/2-2	20.1-29	31	5	8
4603S-357S	4614S-357S	1 1/2-2	29.1-35	36	5	9
4603S-358S	4614S-358S	1 1/2-2	35.1-49	48	5	12
4603S-394S	—	3-4	8	20	5	6
4603S-360S	4614S-360S	3-4	10	23	5	6
4603S-361S	4614S-361S	3-4	10.1-15	31	5	8
4603S-362S	4614S-362S	3-4	15.1-18	36	5	9
4603S-363S	4614S-363S	3-4	18.1-25	48	5	12
4603S-367S	4614S-367S	5-6	10	31	5	8
4603S-368S	4614S-368S	5-6	10.1-12	36	5	9
4603S-369S	4614S-369S	5-6	12.1-17	48	5	12
4603S-395S	—	8	8	36	5	9
4603S-396S	—	8	8.1-12	48	5	12
4603S-397S	—	10	10	48	5	12

Series 622 hand chain hoist

- Simple, efficient, economical design
- Equipped with hardened load chain for flexibility and long wear
- Compact design, low headroom and lightweight steel construction for easy installation, even in confined spaces
- Weston-type load brake requires no lubrication
- Hand wheel cover with guide slots minimizes jamming and slipping
- Forged swivel hooks with latches reduce twisting of chain and unintentional unhooking of load when chain is slack
- Standard hand chain drop is 2 feet less than lift (example: 8 foot lift hoist has 6 foot hand chain drop)
- One-year warranty
- Metric rated
- Imported



Specifications

Product code	Rated capacity* (tons)	Standard lift (ft.)	Chain pull to lift rated load (lbs.)	Hand chain overhauled to lift load one foot (ft.)	Approx. shipping weight (lbs.)
2255	1/2	10	53	29	18
2208	1/2	15	53	29	25
2231	1/2	20	53	29	30
2263	1/2	30	53	29	38
2256	1	10	77	37	26
2210	1	15	77	37	30
2262	1	20	77	37	38
2264	1	30	77	37	48
2258	2	10	82	80	61
2213	2	15	82	80	71
2233	2	20	82	80	80
2272	2	30	85	80	85
2259	3	10	65	154	89
2223	3	15	65	154	99
2214	3	20	65	154	109
2260	5	10	105	147	91
2257	5	15	105	147	107
2234	5	20	105	147	123
2277	10	10	109	289	170

Series 622 hand chain hoist-specifications

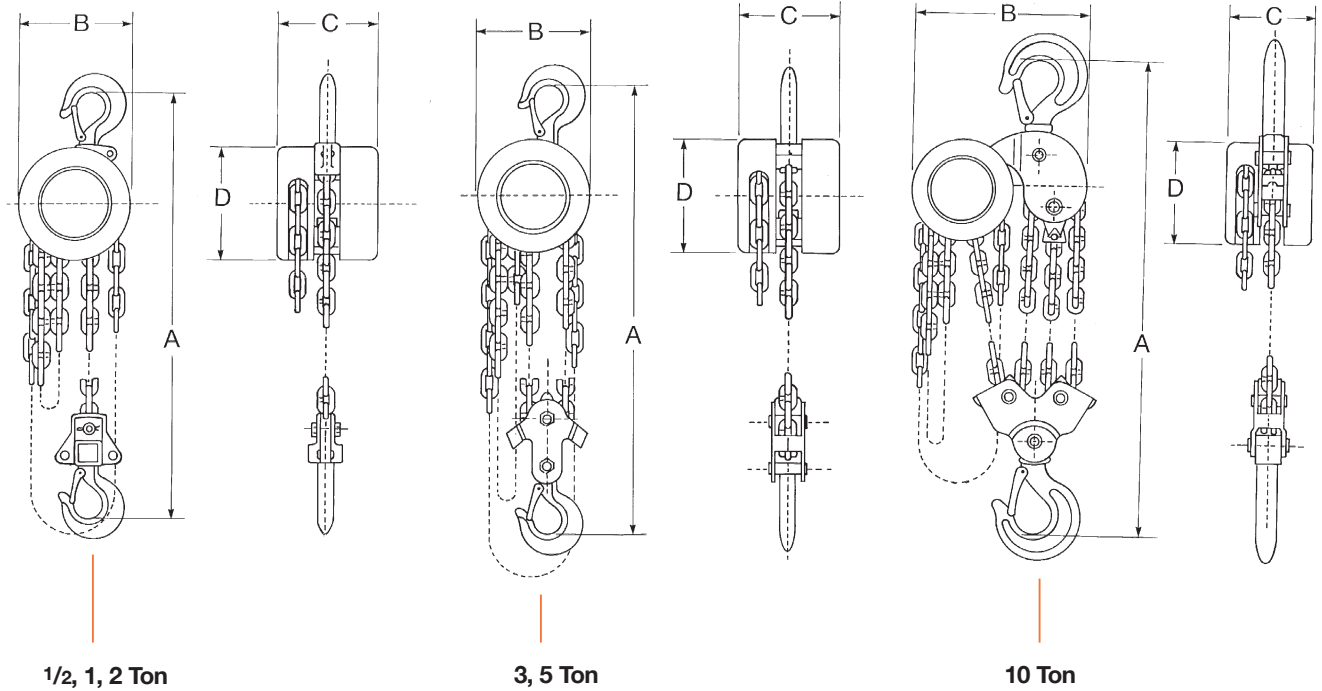

*WARNING
Overloading and improper use can result in injury.
<p>To avoid injury:</p> <ul style="list-style-type: none"> • Do not exceed working load limit, load rating capacity • Do not use to lift people or loads over people. • use only alloy chain for overhead lifting. • Read and follow all instructions.

Clearance dimensions (in.)

Dimension	Rated capacity* (tons)					
	1/2	1	2	3	5	10
A (Headroom)	11 ⁵ / ₈	13	18 ¹ / ₈	21 ²⁹ / ₃₂	23 ⁷ / ₈	27 ⁹ / ₁₆
B (Width)	4 ¹⁵ / ₁₆	5 ¹⁹ / ₃₂	8 ⁵ / ₁₆	8 ⁵ / ₁₆	8 ⁵ / ₁₆	14 ³ / ₃₂
C (Depth)	4 ⁵ / ₁₆	5 ¹ / ₁₆	6 ⁵ / ₈	6 ⁵ / ₈	6 ⁵ / ₈	6 ⁵ / ₈
D (Diameter)	4 ¹⁵ / ₁₆	5 ¹⁹ / ₃₂	8 ⁵ / ₁₆	8 ⁵ / ₁₆	8 ⁵ / ₁₆	8 ⁵ / ₁₆
Hook opening (upper)	1 ¹ / ₁₆	1 ¹ / ₃₂	1 ¹ / ₄	1 ⁵ / ₁₆	1 ¹³ / ₁₆	2 ¹ / ₂
Hook opening (lower)	1 ¹ / ₁₆	1 ¹ / ₃₂	1 ¹ / ₄	1 ⁵ / ₁₆	1 ¹³ / ₁₆	2 ¹ / ₂

Series 602/603 mini ratchet lever hoist

Mini-Ratchet Lever Hoists lift up to 1100 lbs. plus the convenience of toolbox storage.

The CM Series 603 & 602 Mini- Hoists are the most compact ratchet lever hoists in the market, perform just like the larger models, plus come standard with these great features:

- Plated load chain is standard.
- Weston-type load brake.
- Rubber hand grip for better comfort and security.
- Lightweight design for ease of portability. Use in confined conditions with one-hand operation.
- Forged upper and lower hooks with latches standard.
- Impact resistant, all-steel frame, gear case and cover.
- Hardened link-type alloy steel load chain for strength and long wear.
- Free wheeling feature serves to quickly attach the load.
- Metric rated.



Our compact Mini-Hoists perform just like the larger hoists, except they're small enough to fit in the palm of your hand.



Series 602 Convenient Carry Bag - Product Code # 0212



Series 603 Convenient Carry Bag - Product Code # 0217

SPECIFICATIONS

Product Code	Model Number	Rated Capacity (Lbs.)	Rated Capacity (Kg.)	Standard Lift	Number of Chainfalls	Minimum Distance Between Hooks (In.)	Lift w/ One Full Lever Turn (In.)	Handle Length (In.)	Handle Pull @ W.L.L. (Lbs.)	Approx. shipping wgt. (lbs)
0210	Series 602	550	250	5	1	9.45	3.15	6.300	56	6
0214	Series 602 w/10' lift	550	250	10	1					7
0212	Series 602 Carry Bag									.3
0215	Series 603	1,100	500	5	1	11.125	1.57	6.375	78	7
0216	Series 603 w/10' lift	1,100	500	10	1	11.125	1.57	6.375	78	8
0217	Series 603 Carry bag									.3

Series 602 mini ratchet lever hoist-Specifications

Dimensional Drawing - 602

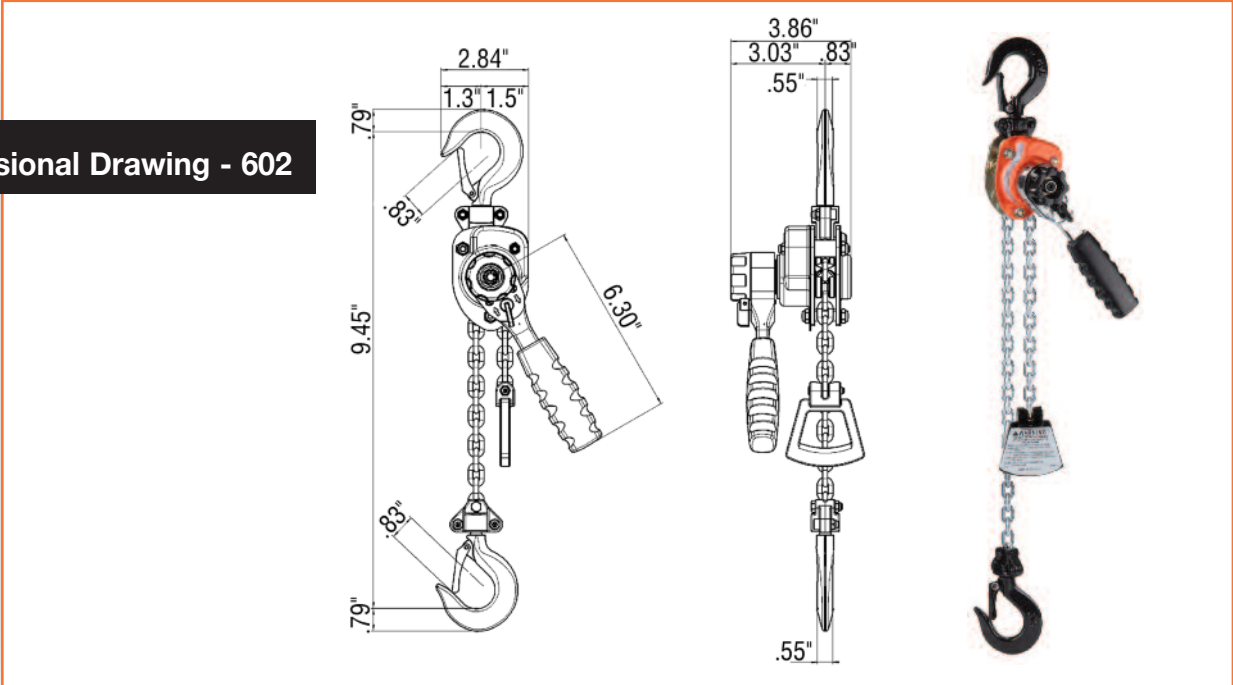

Dimensional Drawing - 603

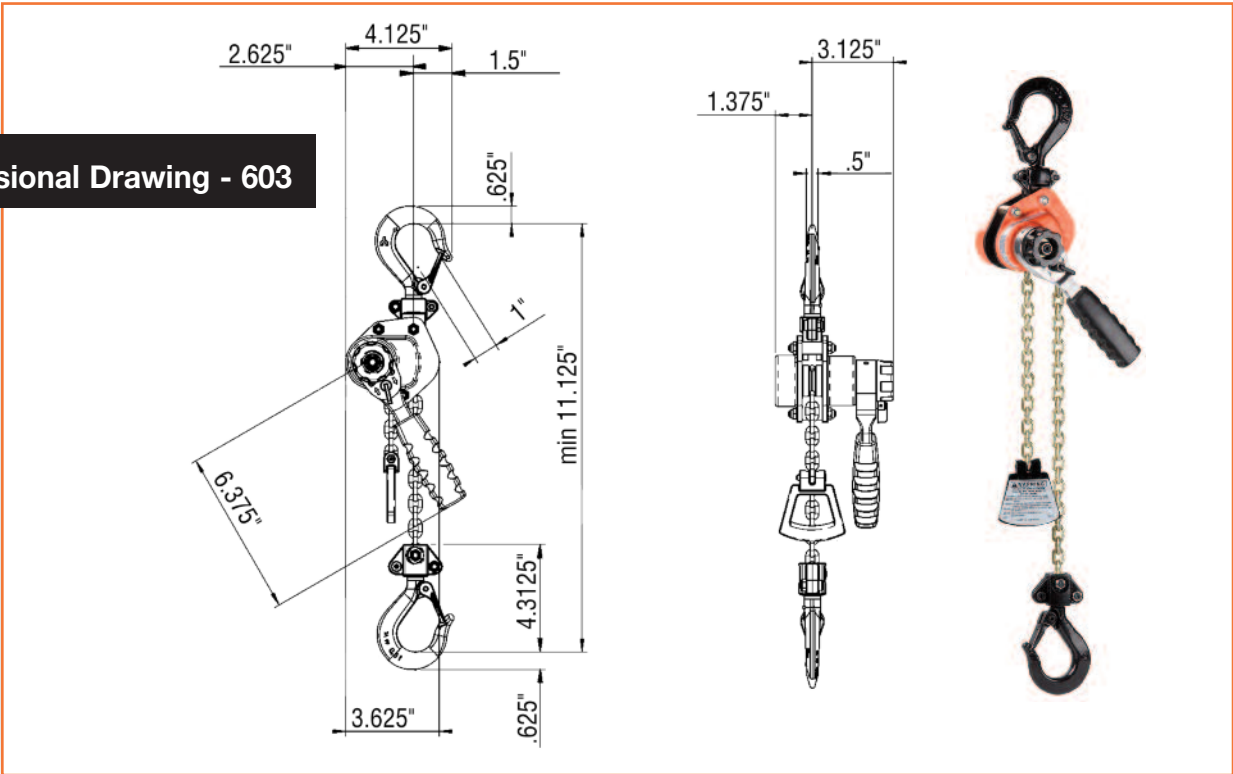

Bandit Ratchet Lever Hoist

The CM® Bandit™ is one of the most compact and durable ratchet lever hoists in the industry. Its lightweight and portable design, easy free-chaining feature and 360° rotating handle make it one of the most versatile hoists on the market today. Now available in 3/4, 1-1/2, 3 and 6 ton capacities for all of your pulling and lifting needs.

CAPACITIES & LIFT

Capacities of 3/4, 1-1/2, 3 & 6 tons. Metric Rated. Standard lifts up to 20 feet. Longer lifts are available.

COMPACT & PORTABLE DESIGN

Rugged, yet lightweight, design and construction allow the Bandit to be easily transported and used in even the most confining spaces.

OUR FIRST HOIST WITH CM® SMART ID™ RFID TECHNOLOGY!

- Standard on all U.S. Bandit units.
- Chip associated with detailed product information at the factory.



FREE-CHAINING

Easy free-chaining feature allows for quick take up and positioning of slack chain. Designed not to accidentally free chain while under load.

360° ROTATING HANDLE

Full rotation of handle allows for versatile rigging options when working in tight spaces.

LOW HANDLE EFFORT

Double reduction gearing provides easy operation with minimal handle effort.

COMFORT-FIT HANDLE

Screwed-on comfortable rubber grip makes for a secure hold in all environments.

LOAD SECURITY & EASY INSPECTION

Upper and lower hooks feature standard cast safety latches that provide positive and secure load engagement. Hooks are bolted on for easy removal and inspection.

MEETS ASME B30.21

POSITIVE LOAD CONTROL

Enclosed Weston-type load brake stays clean and dry for positive load positioning.

EASY TO POSITION & ATTACH

Upper and lower hooks feature extra-wide throat openings to allow for easier attachment to pick points. Hooks swivel 360° for faster positioning.

BUILT TO LAST

Impact-resistant stamped steel housing withstands repeated rigorous use.

CORROSION RESISTANT

Standard powder coat finish on housing and zinc plating on major components for extra protection against corrosion when working in harsh environments.

100% LOAD TESTED GOLD CHROMATE CHAIN

Proven chain integrity and corrosion resistance.

EASY IDENTIFICATION

Each unit has a unique serial number for easy and accurate identification.

OPTIONAL SHIPYARD HOOKS

Shipyards hooks are available as an option on 1-1/2 & 3 ton units.

OPTIONAL INTERNAL LOAD LIMITER

Allows the handle to rotate but will not lift if load exceeds 125% of the working load limit.

BANDIT HOISTS SHIP IN 3 DAYS OR LESS – GUARANTEED

3/4 & 1-1/2 ton units are eligible for our In-Stock Guarantee.

FAST & EASY PARTS ACCESS

Genuine CM Bandit parts are available in Total Repair Kits and convenient bulk packaging.



3/4 ton US model pictured above



THE WORLD'S FIRST
HMI-CERTIFIED
RATCHET LEVER HOIST

Bandit Ratchet Lever Hoist product at a glance

Capacities (Ton)	In-Stock Guarantee	CM Smart ID RFID	Initial Assembly	Final Assembly	Hook Origin	Tri-Point Hook Inspection	Optional Shipyard Hooks	Chain Origin	Type of Chain	Load Tested
3/4	✓	✓	CMCO China Facility	CMCO USA Facility	CMCO USA Facility			CMCO USA Facility	Gold Chromate	China & USA
1-1/2	✓	✓			CMCO USA Facility		✓			
3		✓			CMCO China Facility	✓	✓			
6		✓			CMCO China Facility	✓				

Check for availability on 3 and 6 ton units.

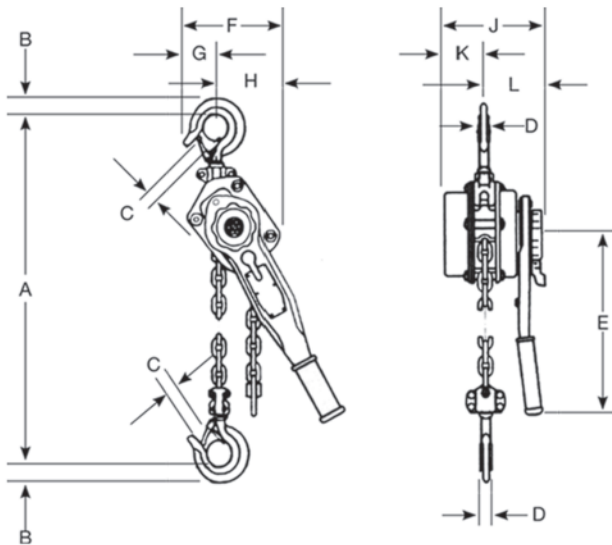

BANDIT TRI-POINT HOOK INSPECTION

Load hooks feature 3 raised points that allow you to measure the hook to detect any indication of overload or deformation.

Available on 3 & 6 ton capacity models.



Bandit Ratchet Lever Hoist specifications

Model Number *	Capacity Metric Rated Ton (kg)	Standard Lift FT (m)	Lever Pull to Lift Rated Load LBF (kg)	Net Weight LB (kg)	Dimensions Inches (mm)										
					A	B	C	D	E	F	G	H	J	K	L
BAN07505	3/4 (750)	5 (1.52)	45 (20.41)	13.6 (6.17)	12.80 (325.12)	0.94 (23.88)	1.13 (28.70)	0.69 (17.53)	9.63 (244.60)	4.88 (123.95)	2.19 (55.63)	3.31 (84.07)	6.06 (153.92)	2.11 (53.59)	3.95 (100.33)
BAN07510		10 (3.05)		15.7 (7.12)											
BAN07515		15 (4.57)		18 (8.16)											
BAN07520		20 (6.1)		20.1 (9.12)											
BAN15005	1-1/2 (1500)	5 (1.52)	64 (29.03)	20.7 (9.39)	14.20 (360.68)	1.13 (28.70)	1.25 (31.75)	0.81 (20.57)	10.25 (260.35)	5.63 (143.00)	2.38 (60.45)	3.56 (90.42)	6.75 (171.45)	2.69 (68.33)	4.13 (104.90)
BAN15010		10 (3.05)		24.3 (11.02)											
BAN15015		15 (4.57)		27.9 (12.65)											
BAN15020		20 (6.1)		31.5 (14.29)											
BAN30005	3 (3000)	5 (1.52)	73 (33.11)	38.3 (17.37)	17.50 (444.5)	1.69 (42.93)	1.56 (39.62)	1.25 (31.75)	16.37 (415.8)	7.52 (191.01)	3.38 (85.85)	4.65 (118.11)	7.84 (199.14)	3.29 (83.57)	4.56 (115.82)
BAN30010		10 (3.05)		45.7 (20.73)											
BAN30015		15 (4.57)		53 (24.04)											
BAN30020		20 (6.1)		60.4 (27.4)											
BAN60005	6 (6000)	5 (1.52)	93 (42.18)	63.2 (28.67)	22.00 (558.8)	1.81 (45.97)	2.19 (55.63)	1.50 (38.1)	16.37 (415.8)	9.47 (240.54)	3.38 (85.85)	6.05 (153.67)	7.84 (199.14)	3.29 (83.57)	4.56 (115.82)
BAN60010		10 (3.05)		77.9 (35.33)											
BAN60015		15 (4.57)		92.6 (42.00)											
BAN60020		20 (6.1)		107.3 (48.7)											

Check for availability on 3 and 6 ton units.

Tornado 360 Ratchet Lever Hoist

Redefining lever-operated hoists, the CM® Tornado 360™ features the revolutionary Sidewinder™ lever handle that allows for efficient operation in both lifting and pulling applications. Ergonomically designed for increased safety, the patent-pending CM Tornado 360° lets the operator work up to 12 times faster and with as much as 30% less pull force than with conventional ratchet lever tools.

Available in 3/4, 1-1/2, 3 and 6 Ton capacities with standard lifts up to 20 feet.

STANDARD FEATURES

SIDEWINDER LEVER HANDLE

This first-of-its-kind lever handle design will revolutionize the ratchet lever hoist industry. Its unique foldable handle and 360° rotating lever increases productivity while reducing the risk of operator injury.

CONVENIENT DIRECTIONAL INDICATOR

Easy-to-use, highly visible directional indicator located on the handle clearly shows the operating direction as lifting, lowering or neutral.

EASY & SMOOTH FREE CHAINING

For quick take up and positioning of slack chain – even with one hand. Designed not to accidentally free chain while under load. Cast chain end stop allows the user to easily position the chain in free-chaining mode and prevents it from entering the liftwheel and jamming the hoist.

POSITIVE LOAD CONTROL

Enclosed Weston-type brake stays clean and dry for precise load positioning.

BUILT TO LAST

Lightweight aluminum housing withstands rigorous use and features high-quality, long-lasting bearings. Powder coat finish provides extra protection in harsh environments.

MEETS ASME B30.21

EXCELLENT CORROSION PROTECTION

Robust chain guide and chain stripper made from cast steel and zinc-plated for corrosion protection.

100% LOAD TESTED CHAIN

U.S. units contain gold chromate chain designed and manufactured in the U.S.A. by Columbus McKinnon. Canadian units contain zinc-plated chain. Both chain finishes protect against corrosion.

EASY-TO-INSPECT SWIVEL HOOKS

Bolt-on hooks with nylon locks help users comply with ASME B30.21 and B30.10 inspection requirements. Hooks are forged, allowing them to yield under overload without breaking. Cast safety latches provide positive and secure load engagement.

INDUSTRY-LEADING WARRANTY

Our lifetime warranty on all mechanical components, including the Sidewinder lever handle, is the industry's best warranty against manufacturing and material defects.

With our 3-year brake warranty, if the brake discs wear out within 3 years from the date of purchase, CMCO will replace the ratchet disc assembly free of charge.

EASY IDENTIFICATION

Each unit has a unique serial number for easy and accurate identification.



US model pictured above

OPTIONAL FEATURES

SHIPYARD HOOKS

Available on 1-1/2 and 3 ton units only.

INTERNAL LOAD LIMITER

Allows the handle to rotate freely, preventing the lifting of an overload sufficient to damage the hoist. Units equipped with a load limiter feature a black hand wheel for quick and easy on-site identification.

CM SMART ID™ RADIO FREQUENCY IDENTIFICATION

Simplify inventory and inspection management processes.

At a Glance

EASILY CHANGE YOUR GRIP TO SUIT THE APPLICATION

The CM Tornado 360° gives operators ultimate flexibility. When an application requires a customary ratcheting hand grip, the Tornado 360° can be operated like a traditional lever tool when the lever handle is in the upright position. inspection management processes.

ERGONOMIC DESIGN DELIVERS OPTIMAL OPERATOR SAFETY

- Hoist design allows the operator to work in a safe and ergonomic position.
- Sidewinder lever handle enables smooth 360° operation, reducing repetitive wrist action experienced with traditional ratchet lever hoists.
- Double reduction gearing and high-quality bearings decrease required pull force by up to 30%, reducing operator fatigue.

EASILY CARRY & TRANSPORT WITH JUST ONE HAND

When folded out, the lever handle can serve as a carrying grip for easy transport. Simply attach the end stop to the hook and slip the hook onto the Sidewinder lever handle to lift and carry the unit with one hand.

EASIER MAINTENANCE & INSPECTION

For quicker maintenance and lower repair costs, screws are set into the hoist body to protect them from potential damage.

To ensure optimal performance and safety, demand genuine CMCO parts. Protect your investment, maintain warranty requirements and preserve the integrity of your hoist's superior design – ask for Parts Star™ by Columbus McKinnon.

Specifications

Capacity Tons (kg.)	Product Code		Standard Lift ft. (m)	Pull Force to Lift Rated Load lb./ft. (kg./ft.)		Reeving	Weight lbs. (kg)	Dimensions in. (mm)														
	without load limiter	with load limiter		Sidewinder Lever Handle Operation	Traditional Lever Operation			A (Min)	B	C	D	E	F	G	H	J	K	L	M	N	O	P
0.75 (750)	TOR07505	TOR07505LL	5 (1.5)	38.2 (17.3)	47.2 (21.4)	1	14.6 (6.62)	12.60 (320)	0.79 (20)	1.06 (27)	0.71 (18)	12.87 (327)	11.81 (300)	1.57 (40)	3.19 (81)	4.76 (121)	2.20 (56)	4.13 (105)	6.33 (161)	1.18 (30)	4.72 (120)	10.1 (257)
	TOR07510	TOR07510LL	10 (3.0)				16.8 (7.62)															
	TOR07515	TOR07515LL	15 (4.5)				19.0 (8.62)															
	TOR07520	TOR07520LL	20 (6.0)				21.2 (9.62)															
	TOR075LCX	TOR075LCXLL	Less Chain				11.95 (5.42)															
1.5 (1,500)	TOR15005	TOR15005LL	5 (1.5)	58.5 (26.5)	60.7 (27.5)	1	21.0 (9.52)	14.76 (375)	1.02 (26)	1.22 (31)	0.83 (21)	12.87 (327)	11.81 (300)	2.01 (51)	3.78 (96)	5.79 (147)	2.71 (69)	4.33 (110)	7.05 (179)	1.18 (30)	4.72 (120)	10.7 (273)
	TOR15010	TOR15010LL	10 (3.0)				24.5 (11.11)															
	TOR15015	TOR15015LL	15 (4.5)				28.1 (12.75)															
	TOR15020	TOR15020LL	20 (6.0)				31.6 (14.33)															
	TOR150LCX	TOR150LCXLL	Less Chain				16.71 (7.58)															
	00002145	Optional Upper Shipyard Hook					4.4 (2.00)															
3315WLP	Optional Lower Shipyard Hook					2.87 (1.30)	3.56	28	27	23	327	300	37	96	133	69	110	179	30	120	273	
3 (3,000)	TOR30005	TOR30005LL	5 (1.5)	79.4 (36)	90.4 (41)	1	36.61 (16.61)	17.52 (445)	1.46 (37)	1.57 (40)	1.10 (28)	14.84 (377)	13.78 (350)	2.24 (57)	4.84 (123)	7.09 (180)	3.39 (86)	4.76 (121)	8.15 (207)	1.18 (30)	4.72 (120)	11.77 (299)
	TOR30010	TOR30010LL	10 (3.0)				44.01 (19.96)															
	TOR30015	TOR30015LL	15 (4.5)				51.41 (23.32)															
	TOR30020	TOR30020LL	20 (6.0)				58.81 (26.68)															
	TOR300LCX	TOR300LCXLL	Less Chain				29.21 (13.25)															
	00002383	Optional Upper Shipyard Hook					4.23 (1.92)															
3403WLP	Optional Lower Shipyard Hook					4.81 (2.18)	436	37	36	28	377	350	48	123	171	86	121	207	30	120	299	
6 (6,000)	TOR60005	TOR60005LL	5 (1.5)	83.8 (38)	92.6 (42)	2	52.26 (23.70)	22.17 (563)	1.77 (45)	1.73 (44)	1.38 (35)	14.84 (377)	13.78 (350)	2.80 (71)	6.38 (162)	9.17 (233)	3.39 (86)	4.76 (121)	8.15 (207)	1.18 (30)	4.72 (120)	11.77 (299)
	TOR60010	TOR60010LL	10 (3.0)				59.66 (27.06)															
	TOR60015	TOR60015LL	15 (4.5)				67.06 (30.42)															
	TOR60020	TOR60020LL	20 (6.0)				74.46 (33.77)															
	TOR600LCX	TOR600LCXLL	Less Chain				44.86 (20.35)															

3/4, 1-1/2 AND 3 TON UNITS

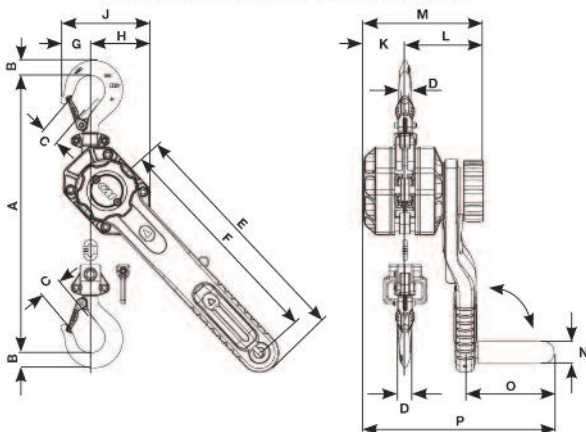

6 TON UNITS

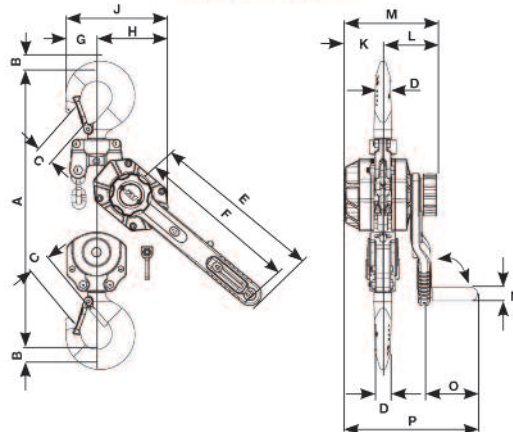

Tornado 360 Ratchet Lever Hoist

THE REVOLUTIONARY SIDEWINDER™ LEVER HANDLE

The patent-pending CM Tornado 360° ratchet lever hoist features the revolutionary Sidewinder™ lever handle. What makes the Sidewinder so unique are two innovative components:

1. 360° ROTATING LEVER

The unique offset, or curved, design of the lever keeps the operator's hand and body aligned with the load chain. This reduces the risk of the twist effect (when a hoist twists around the chain) and the need to stabilize the hoist with another hand.

2. FOLD-OUT REVOLVING HANDLE

Recessed in the lever, the heavy-duty steel core handle folds down into position on either side of the lever, allowing for easy operation from any angle. The handle is grooved to provide a secure grip – even with gloves.

The handle revolves, allowing the operator to ergonomically and easily maintain control of the lever through its full 360° range of motion.

Together, the Sidewinder's lever and handle allow the operator to realize the full potential of 360° rotation, making the CM Tornado 360° unlike any other ratchet lever hoist on the market:

- 360° rotation increases efficiency, allowing operators to work up to 12 times faster than with a conventional ratchet lever hoist.
- Minimal effort with best-in-class lever pull force that beats the competition: 38.2 lb./ft. for the 3/4 ton unit and 58.5 lb./ft. for the 1-1/2 ton unit.

**DISTINCTIVE
CLICKING SOUND**
ENSURES THE HANDLE
IS LOCKED INTO POSITION

To return handle to upright position,
simply pull the handle outward
and snap into place inside the lever.

FOLD-OUT REVOLVING HANDLE

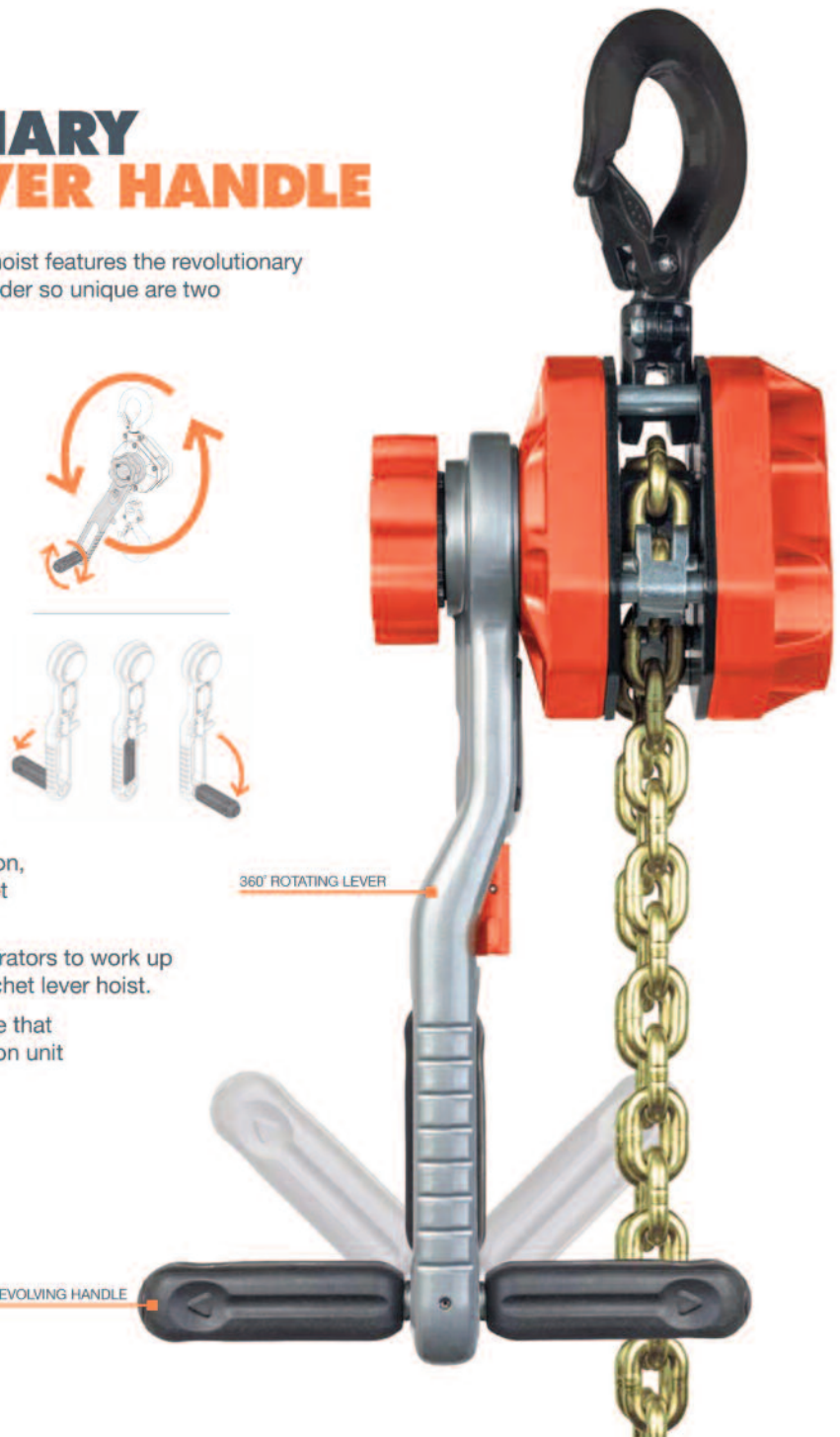

EASY-TO-USE DIRECTIONAL CONTROL & FREE CHAINING

CONVENIENT DIRECTIONAL INDICATOR

Easy-to-use, highly visible directional indicator window located in the lever clearly shows the operating direction as lifting (▲), lowering (▼) or neutral (N).

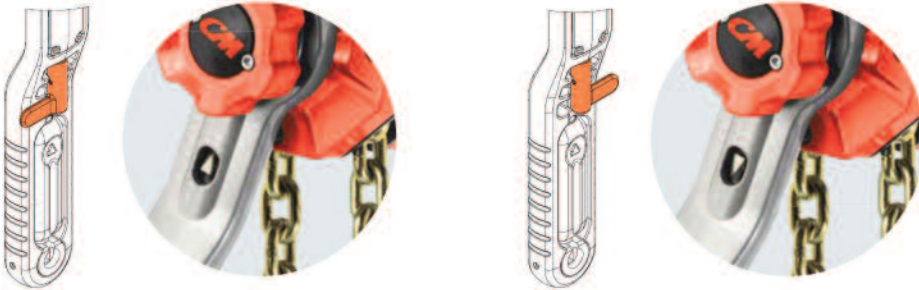

EASY & SMOOTH FREE CHAINING

Allows for quick take up and positioning of slack chain – even with one-handed use. Designed not to accidentally free chain while under load. Cast chain end stop allows the user to quickly position the chain in free-chaining mode and prevents it from entering the liftwheel and jamming the hoist.

In this mode of operation, the chain can be pulled through the hoist in either direction by hand for quick attachment to the load. To engage the free chaining feature, remove the load and move the directional lever to the neutral (N) position.

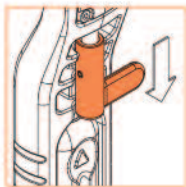

SAFE & SECURE SELECTOR LEVER LOCKS IN PLACE TO PREVENT ACCIDENTALLY SWITCHING.

Pull down on the selector lever to unlock it, turn it to the desired direction, and release it into the locking position.

Series 653 Ratchet Lever hoist

As part of our commitment to bring best-in-class products to market, we are continuously looking to improve existing products. Our popular CM Series 653 ratchet lever hoist has been redesigned with a shorter handle. This modest modification makes a world of difference. Ideal for confined work areas, the Series 653 3/4 and 1-1/2 ton models are now some of the most nimble and easiest to operate hoists on the market today.

CAPACITIES & LIFT

3/4 & 1-1/2 Ton capacities (new shorter handle). 3 & 6 Ton capacities (standard handle). Metric Rated. Standard Lift up to 20 feet.

COMPACT & PORTABLE DESIGN

Take this rugged hoist anywhere. Easily transported and rigged even in the smallest work spaces.

FREE CHAINING

Single-handed free chaining feature allows for quick take up and positioning of slack chain. Designed not to accidentally free chain while under load.

360° ROTATING HANDLE

Full rotation of handle allows for versatile rigging options when working in confined spaces.

RUGGED DESIGN

Impact resistant stamped steel frame and gear cover withstands repeated rigorous use.

BUILT TO LAST

Zinc plated hardened steel chain provides strength and longer wear life which translates to less down time.

POSITIVE LOAD CONTROL

Enclosed Weston type load brake stays clean and dry for positive load positioning.

LOAD CONTROL

Double pawl design ensures that one pawl will be engaged at all times for reliable load control.

SAFE & SECURE

Standard heavy duty forged safety latches on hooks provide positive and secure load engagement.

CORROSION RESISTANT

Standard powder coat finish for extra protection against corrosion when working in harsh environments.

NON-SLIP RUBBER HANDLE GRIP

Comfortable rubber grip provides for extra protection against slippage.

Meets ASME B30.21

5 YEAR WARRANTY

THE ADVANTAGES OF THE SHORTER HANDLE

LESS WEIGHT TO TRANSPORT

Reduces the overall weight of the hoist, making it even easier to carry and operate.

FITS IN SMALL WORK AREAS

The smaller handle allows the Series 653 to fit into confined work areas.

MAKE THE FULL ROTATION

Take full advantage of the 360° rotating handle with less worry of obstructions.



***WARNING**

Overloading and improper use can result in injury.

To avoid injury:

- Do not exceed working load limit, load rating capacity
- Do not use to lift people or loads over people.
- use only alloy chain for overhead lifting.
- Read and follow all instructions.

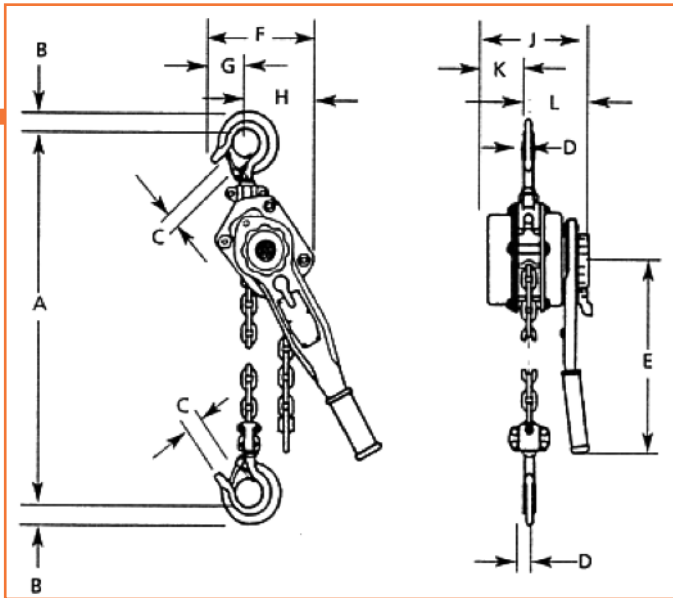

Series 653 lever operated hoist-specifications

	Capacity (tons)	Product code	Net Wt. (lbs.)
Upper Shipyard hook	1 1/2	3315WLP	2.9
	3	3303WLP	4.9
Lower Shipyard hook	1 1/2	3415WLP	2.1
	3	3403WLP	4.8

Product Code	Max. Capacity (tons)	Standard Lift (ft.)	Approx. Shipping wt. (lbs.)
5336	1 1/2	5	27
5337	1 1/2	5	28
5338	3	5	45
5339	3	5	46

Specifications

Product code	Load rating (tonnes)	Lift or reach (ft.)	Lever pull to lift rated load (lbs.)	Approx. ship wt. (lbs.)	A	B	C	D	E	F	G	H	J	K	L
5310	3/4	5	33	15.0	12 ⁵ / ₈	15/16	1 ¹ / ₈	11/16	9 ¹ / ₄	4 ³ / ₈	2 ³ / ₁₆	2 ³ / ₁₆	5 ¹⁵ / ₁₆	2 ³ / ₈	3 ⁹ / ₁₆
5311	3/4	10	33	15.8	12 ⁵ / ₈	15/16	1 ¹ / ₈	11/16	9 ¹ / ₄	4 ³ / ₈	2 ³ / ₁₆	2 ³ / ₁₆	5 ¹⁵ / ₁₆	2 ³ / ₈	3 ⁹ / ₁₆
5312	3/4	15	33	16.6	12 ⁵ / ₈	15/16	1 ¹ / ₈	11/16	9 ¹ / ₄	4 ³ / ₈	2 ³ / ₁₆	2 ³ / ₁₆	5 ¹⁵ / ₁₆	2 ³ / ₈	3 ⁹ / ₁₆
5313	3/4	20	33	17.3	12 ⁵ / ₈	15/16	1 ¹ / ₈	11/16	9 ¹ / ₄	4 ³ / ₈	2 ³ / ₁₆	2 ³ / ₁₆	5 ¹⁵ / ₁₆	2 ³ / ₈	3 ⁹ / ₁₆
5328	1	5	44	15.0	12 ⁵ / ₈	15/16	1 ¹ / ₈	11/16	9 ¹ / ₄	4 ³ / ₈	2 ³ / ₁₆	2 ³ / ₁₆	5 ¹⁵ / ₁₆	2 ³ / ₈	3 ⁹ / ₁₆
5315	1 1/2	5	51	27.0	14 ³ / ₁₆	1 ¹ / ₈	1 ¹ / ₄	13/16	13	4 ³ / ₈	2 ³ / ₈	2 ³ / ₈	6 ⁷ / ₈	3	3 ¹⁵ / ₁₆
5316	1 1/2	10	51	31.4	14 ³ / ₁₆	1 ¹ / ₈	1 ¹ / ₄	13/16	13	4 ³ / ₈	2 ³ / ₈	2 ³ / ₈	6 ⁷ / ₈	3	3 ¹⁵ / ₁₆
5317	1 1/2	15	51	35.8	14 ³ / ₁₆	1 ¹ / ₈	1 ¹ / ₄	13/16	13	4 ³ / ₈	2 ³ / ₈	2 ³ / ₈	6 ⁷ / ₈	3	3 ¹⁵ / ₁₆
5318	1 1/2	20	51	40.2	14 ³ / ₁₆	1 ¹ / ₈	1 ¹ / ₄	13/16	13	4 ³ / ₈	2 ³ / ₈	2 ³ / ₈	6 ⁷ / ₈	3	3 ¹⁵ / ₁₆
5329	2	5	68	27.0	14 ¹³ / ₁₆	1 ¹ / ₈	1 ¹ / ₄	13/16	16 ¹ / ₄	4 ³ / ₈	2 ³ / ₈	2 ³ / ₈	6 ⁷ / ₈	3	3 ¹⁵ / ₁₆
5320	3	5	77	45.0	18 ¹¹ / ₁₆	1 ¹³ / ₁₆	1 ⁹ / ₁₆	1 ¹ / ₄	16 ¹ / ₄	7 ¹ / ₂	3 ³ / ₈	4 ³ / ₁₆	7 ⁷ / ₈	3 ³ / ₈	4 ⁹ / ₁₆
5321	3	10	77	52.3	18 ¹¹ / ₁₆	1 ¹³ / ₁₆	1 ⁹ / ₁₆	1 ¹ / ₄	16 ¹ / ₄	7 ¹ / ₂	3 ³ / ₈	4 ³ / ₁₆	7 ⁷ / ₈	3 ³ / ₈	4 ⁹ / ₁₆
5330	6	5	77	78.0	23 ¹ / ₄	1 ¹³ / ₁₆	2 ³ / ₁₆	1 ¹ / ₂	16 ¹ / ₄	7 ¹ / ₂	3 ³ / ₈	4 ³ / ₁₆	7 ⁷ / ₈	3 ³ / ₈	4 ⁹ / ₁₆
5331	6	10	77	94.0	23 ¹ / ₄	1 ¹³ / ₁₆	2 ³ / ₁₆	1 ¹ / ₂	16 ¹ / ₄	7 ¹ / ₂	3 ³ / ₈	4 ³ / ₁₆	7 ⁷ / ₈	3 ³ / ₈	4 ⁹ / ₁₆
5332	6	15	77	110.0	23 ¹ / ₄	1 ¹³ / ₁₆	2 ³ / ₁₆	1 ¹ / ₂	16 ¹ / ₄	7 ¹ / ₂	3 ³ / ₈	4 ³ / ₁₆	7 ⁷ / ₈	3 ³ / ₈	4 ⁹ / ₁₆
5333	6	20	77	126.0	23 ¹ / ₄	1 ¹³ / ₁₆	2 ³ / ₁₆	1 ¹ / ₂	16 ¹ / ₄	7 ¹ / ₂	3 ³ / ₈	4 ³ / ₁₆	7 ⁷ / ₈	3 ³ / ₈	4 ⁹ / ₁₆



Shipyard hooks are available for use with the Series 653 in shipbuilding and metal fabrication industries. The upper shipyard hook replaces the standard hook and easily attaches to the body of the hoist. The lower hook is furnished with a chain block for direct attachment to the load of the hoist. Shipyard hooks are excellent for positioning steel plate and fixtures during welding applications.

Puller



The CM Puller is designed for heavy-duty construction and industrial applications. Used to pull, lift, drag or stretch, it features:

- Tough aluminum alloy construction and powder coat finish
- Weatherproof for outdoor service
- Simple construction with fewer parts for ease of maintenance and lower inventories
- Hoistaloy hardened steel link type load chain for strength, long wear life and flexibility
- Weatherized Weston-type automatic braking system for positive load control
- Easy, one-hand operation and control — only 58 pounds of pull required for ¾ ton model capacity
- Forged upper and lower hooks with latches standard
- Free wheeling for fast and easy attachment to load
- Upper and lower Latchlok hooks available for all capacities
- Optional Load Limiter protection device stops transmission of lever forces protecting against dangerous overload
- Optional anchor sling simplifies attachment to allow anchor hook to swivel in tight space applications (¾ & 1½ ton units only)
- Optional Load Sentry warns of overload condition
- Optional zinc-plated chain available
- Unlimited lift
- Lifetime warranty
- Metric rated
- Made in U.S.A.



Optional Load Limiter



Optional anchor sling (¾ and 1½ ton)

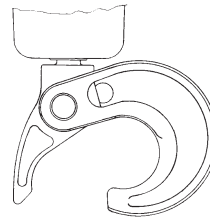

Latchlok type hook



¾ ton

Puller specifications - standard unit

Rated capacity* (tons)	Product code	Standard lift† (ft.)	Pull to lift full loads (lbs.)	Minimum distance between hooks (in.)	Lever length (in.)	Reeving	Hook throat openings (in.)	Approx. shipping weight (lbs.)
¾	4043	5	58	10¾	21¼	1	1½	16
1½	4045	5	89	14¼	21¼	1	1½	26
3	4047	5	95	16 ¹⁵ / ₁₆	21¼	2	1 ⁷ / ₃₂	38
6	4050	5	96	21¾	21¼	4	1¾	73

† Can be supplied with lifts longer than 5 feet

Optional kits

Rated capacity* (tons)	Load Limiter		Load Sentry kit			Anchor sling kit	
	Product code	Approx. shipping weight (lbs.)	Product code	Lever length (in.)	Approx. shipping weight (lbs.)	Product code	Approx. shipping weight (lbs.)
¾	4190	8¼	4096	23¾	4½	4071	2
1½	4191	8¼	4098	23¾	4½	4072	4¾
3	4191	8¼	4098	23¾	4½	—	—
6	4191	8¼	4098	23¾	4½	—	—

Short handle puller

The CM Short Handle Puller is designed for easy operation, especially in hard to reach small spaces. It features:

- Easy one-hand operation
- Lever pull range is 45 to 62 pounds to lift full load
- Handle that rotates 360°, making it easy to operate in any position and in small spaces
- Tough yet lightweight aluminum construction and powder coat finish
- Hoist alloy hardened steel load chain for strength, long wear life and flexibility
- Free chaining for fast, easy attachment to load
- Forged upper and lower hooks with latches
- Simple construction with fewer parts for ease of maintenance
- Optional Load Limiter device protects against overload
- Lifetime warranty
- Made in U.S.A.



Specifications - Short handle puller

Rated capacity* (tons)	Product code	Standard lift (ft.)	Pull to lift full loads (lbs.)	Minimum distance between hooks (in.)	Lever length (in.)	Reeving	Hook throat openings (in.)	Approx. shipping weight (lbs.)
3/4	7300P	5	45	12 1/4	12	1	1 1/32	16
1 1/2	7320P	5	55	14 3/4	16 3/4	1	1 1/8	27
3	7330P	5	62	17 5/8	16 3/4	2	1 3/16	40

Specifications - Short handle puller without chain

Rated capacity* (tons)	Product code	Approx. shipping weight (lbs.)
3/4	7301P	12
1 1/2	7321P	21
3	7331P	28



Optional Load Limiter



Optional upper Latchlok Hook 3/4 – 1 1/2 ton



Optional anchor sling

Optional kits

	Product code	Approx. shipping weight (lbs.)	Rated capacity* (tons)	
Load Limiter	7310P	1	3/4	
	7311P	2	1 1/2-3	
Anchor Sling	7309P	2	3/4	
	7312P	3	1 1/2	
	1001	2	3/4	
Latchlok Hook	1003	2	1 1/2	
	1004	3	3	
	upper	1001	2	3/4
		1003	2	1 1/2
	lower	1003	2	1 1/2
1005		3	3	



Optional upper Latchlok Hook 3 ton

Rigger lever operated hoist

Designed for moderate commercial applications, this lightweight, compact tool stores easily and features:



- Flexible, non-binding CM load chain
- Forged upper and lower hooks with latches standard
- Free-wheeling chain for fast attachment
- Clover leaf chain guides and stripper seat chain in liftwheel reduce chance of jamming
- Unlimited lift by ordering any length chain
- Ratchet, driving pawl and holding pawl for load control
- One lever used to change from lifting to lowering and back to lifting
- Easy maintenance
- One-year warranty
- Metric rated
- Made in U.S.A.

* **WARNING**

Overloading and improper use can result in injury.

To avoid injury:

- Do not exceed working load limit, load rating capacity
- Do not use to lift people or loads over people.
- use only alloy chain for overhead lifting.
- Read and follow all instructions.

Specifications

Rated capacity* (tons)	Product code	Standard lift† (ft.)	Reeving	Pull to lift full load (lbs.)	Minimum distance between hooks (in.)	Lever length (in.)	Hook throat openings (in.)	Shipping weight (lbs.)
3/4	2301	5	1	98	10 ³ / ₄	15 ³ / ₈	1 ¹ / ₃₂	8 ³ / ₄
1 ¹ / ₂	2302	5	2	98	12 ¹ / ₂	15 ³ / ₈	1 ¹ / ₃₂	13 ³ / ₄

† Can be supplied with lifts longer than 5 feet

Wire rope lever hoists

Engineered for Reliable Operation

- Handle Designed for Overload Protection—Handle bends to warn of hazardous condition and prevent dangerous overload.
- Hooks with Hook Latches—360° swiveling hooks equipped with latches for positive load engagement.
- Meets ANSI Standard B30.21.
- Tested to 125% of Capacity.
- Made in U.S.A.

Portable and Durable

- Lightweight and Rugged—Special cast aluminum alloy housings.
- Heavy Duty Cable—Utilizes preformed and galvanized 7 x 19 (133 strand) extra flexible aircraft cable.
- Corrosion Resistant—All stainless steel springs and shafts.
- Reduced Wear—All rotating shafts are mounted on bronze bushings.

Easy to Operate

- Self-storing Cable Drum—Provides compact operation.
- Fast Cable Take-up—Winding wheel provided for quick take-up or positioning of cable.
- Easy Load Positioning—Utilizes a double interlocking pawl system for precise load adjustment.
- Positive Load Holding in All Environments—Provided by double interlocking pawl mechanism.
- Open Construction—Allows for easy cleaning and inspection.

Special Model Features

- All models are available with Bullard-type hooks.
- CM430CDPA equipped with oversized slip hooks— ideal for opening and closing boxcar doors.



*WARNING

Overloading and improper use can result in injury.

To avoid injury:

- Do not exceed working load limit, load rating capacity
- Do not use to lift people or loads over people.
- use only alloy chain for overhead lifting.
- Read and follow all instructions.

Single & Double Line • 1000 - 4000 Lbs.

Specifications		SINGLE LINE			DOUBLE LINE			Cable Dia. x Length (In.) (Ft.)	Ship Weight (Lbs.)
Product Code	Model	Capacity (Lbs.)	Lift (Ft.)	Hook to Hook (Min.) (In.)	Capacity (Lbs.)	Lift (Ft.)	Hook to Hook (Min.) (in.)		
04601W	115SA	1000	13¾	19	—	—	—	¾ ₁₆ x 16	8¾
04602W	115DA	1000	13½	21	2000	6½	27	¾ ₁₆ x 16	10½
04610W	505NA	1500	13	21	—	—	—	¼ x 15	9½
04611W	202WNA	1500	12½	21	3000	6	27	¼ x 15	11½
04620W	434WNA	1500	21½	22½	3000	10¼	28½	¼ x 24	13¼
04621W	430CDPA	1500	21½	25	3000	10¼	33½	¼ x 24	16
04631W	404WNA	2000	12½	22½	4000	6	28½	9/32 x 15	13½

GT Series

Grip and pull wire rope lever tool

The GT Grip and Pull Lever Tool is a rugged and portable unit designed for heavy duty pulling, rigging, dragging, and stretching applications. Its ability to grip and pull heavy loads over long distances specially suit this tool for use in the construction and transportation industries, as well as hundreds of other industrial applications.

- **CAPACITIES & REACH** - Rated loads from 1 to 3 tons, with standard wire rope length of 32 feet on 1 and 3 ton models; 65 feet on 2 ton model.
- **SMOOTH OPERATION / LOW WEAR** - The large surface area of the dual clamping jaws provides an evenly distributed grip on the wire rope for smooth operation and low wear.
- **POSITIVE LOAD CONTROL** - The greater the force of the pull, the greater the clamping force of the jaws. Unique jaw design prevents damage to the wire rope.
- **LIMITLESS WIRE ROPE TRAVEL** - Versatility for use over long distances.
- **DURABILITY** - Lightweight and compact design for portability, yet built tough for long life and trouble free service.
- **OVERLOAD PROTECTION** - Easily replaceable, shear pin design to protect against dangerous overloads.
- **TELESCOPIC HANDLE** - Enhances portability and ease of operation.
- **MINIMAL MAINTENANCE** - Periodic cleaning, inspection, and lubrication is all that is required.
- **LIFETIME WARRANTY** - Lifetime warranty against defects in materials and workmanship. Refer to full CM Warranty Statement for details.



Specifications

Rated Capacity (Tons)	Model Number	Product Code	Standard Wire Rope Length (Ft.)	Wire Rope Diam. (In.)	Lever Length Extended (In.)	Lever Length Retracted (In.)	Rope Advance† (In.)	Overall Dimensions (In.)	Net Weight* (Lb.)	Net Weight** (Lb.)
1	GT-1300-32	0013	32	3/16	29.1	21.3	1.30	19.7 x 9.1 x 4.0	35	18
2	GT-2000-65	0020	65	7/16	29.1	21.3	1.45	24.8 x 13.0 x 5.9	79	40
3	GT-3500-32	0035	32	5/8	29.1	21.3	0.78	28.6 x 12.8 x 7.0	94	66

† Per Full Stroke at Rated Load

* Wire Rope Included

** Less Wire Rope

Universal Trolley

The CM Universal Trolley (UT) is designed to fit virtually all Columbus McKinnon powered chain hoists up to 3 ton capacities.

CM Lodestar; Classic Lodestar; the new 2-ton, single-reeved Lodestar; Valustar; ShopStar; Man Guard; AirStar and AirStar 6.

COFFING JLC, EC1, EC3, and CAH Small and Large frame.

BUDGIT & YALE BEHC (Manguard), KELC (Manguard), YJL, 2200 Air and 6000 Air.

BENEFITS & FEATURES

UNIVERSAL DESIGN REDUCES INVENTORY

Designed to fit most CMCO brand air and electric chain hoists up to 3 tons, the UT reduces inventory costs while increasing inventory flexibility.

THE SMART & ECONOMICAL CHOICE
With its very attractive price, the ability to be used with a multitude of hoists, and its long service life, the UT offers the greatest value of any trolley on the market today.

CONVERTIBLE

Plain trolleys equipped standard with geared trackwheels and side plate. Simply add a hand-geared kit to convert unit to a geared trolley in the field.

LONG LIFE & LOW MAINTENANCE

Dual tread wheels fit tapered or flat beams. Wheels include permanently lubricated shielded ball bearings for long life and low maintenance.

EASILY ADJUSTABLE TO FIT A WIDE RANGE OF BEAMS

The UT can be quickly and easily adjusted to fit the most popular beam flange widths. Maximum flange width of 8-5/8."

PLAIN & GEARED

CM UT plain trolleys allow for manual positioning of hoist and load, while geared units are ideal for applications where precise positioning is required. CM UT geared trolleys feature standard hand chain drop in proportion to a 20-foot-lift hoist.

MOTORIZED

CM UT motorized trolleys are best for applications requiring high cycling and long-distance hoist travel.

SPEED

15, 35 and 75 FPM traverse speed.

AC POWER SUPPLY

208-230/460 3-60 HZ. Single-speed, three-phase controls standard.

NEMA 3R WEATHER PROOFING

EASY ACCESS CONTROL BOX

Control box design allows the entire cover to be removed for easy access to components. Control box case has a white background for increased visibility when wiring up the panel or making adjustments to controls.

CONVENIENT TOOL TRAY

Electrical panel cover can be used as a tray to hold tools when repairing or servicing on the hoist.

The rugged UT is competitively priced and engineered for maximum versatility and long service life. With 1, 2 and 3 ton (metric rated) capacities, the CM Universal Trolley is available as a convertible plain unit, a geared unit ideal for precise hoist positioning, and a motorized unit that's perfect for applications requiring high cycling and long distance hoist travel. The plain and geared versions of the Universal Trolley are CE Compliant, making them ideal for the global market.



PLAIN

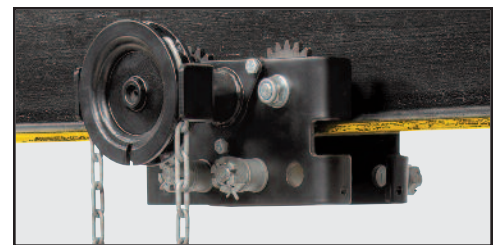

GEARED

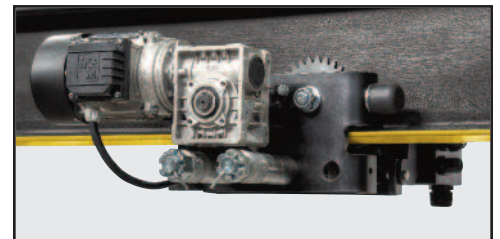

MOTORIZED

CTP Adjustable Trolley Clamp

Capacities up to 6,600 LBS.

The heavy duty adjustable trolley clamp designed for easy installation while offering superior strength and stability throughout its long service life.

QUICK & EASY INSTALLATION

The CTP Adjustable Trolley Clamp requires no tools for installation.

THE SMART & ECONOMICAL CHOICE

With its competitive price and universal hanging clevis able to accept most hoists, the CTP is a tremendous value.

CORROSION RESISTANT

Features a zinc-plated spindle for added protection against the elements.

SAFE & SECURE

The unique locking nut handle prevents spindle from loosening.

METRIC RATED

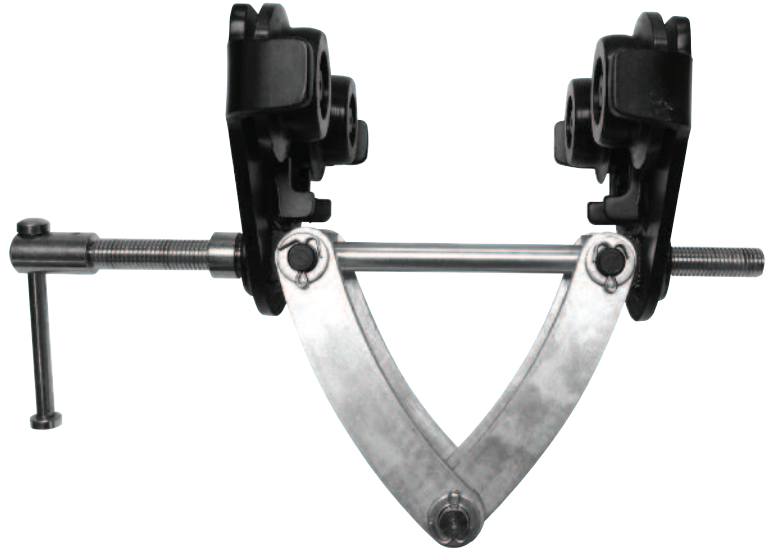

Product Code	Model	Capacity		I Beam Width (in.)	Minimum Radius Curve (in.)	Wheel Diameter (in.)
		Lbs.	Ton			
05500024	CTP/A 1T	2200	1	2-1/4 to 6	24	2.36
05500025	CTP/A 2T	4400	2	3 to 7-7/8	35	3.27
05500026	CTP/B 2T	4400	2	7-7/8 to 11-7/8	35	3.27
05500027	CTP/A 3T	6600	3	3 to 7-7/8	45	4.37
05500028	CTP/B 3T	6600	3	7-7/8 to 12-1/2	45	4.37

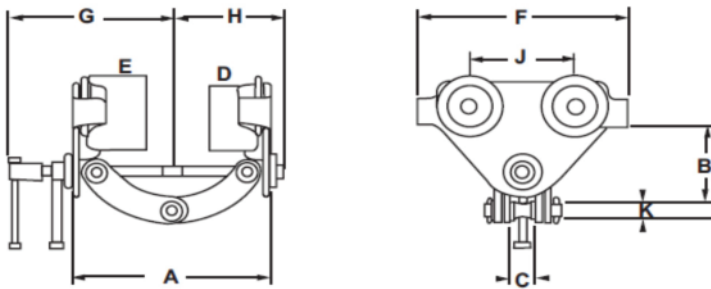

DIMENSION CHART

Model	Part Number	Working Load Limit	Jaw Capacity	Wheel Diameter	Minimum Curve Radius	A		B		C	D	E	F	G	H	J	K	Weight	
						Min	Max	Min	Max										
		Bl	in.	in.	in.	in.	in.	in.	in.	in.	in.	in.	in.	in.	in.	in.	in.	lb.	
CTP/A 1T	005500024	2,200	2-3/8"- 5-7/8"	2.362	24"	3.74	7.283	3.228	4.291	1.026	2.598	2.874	6.299	6.020	4.134	2.952	0.787	5.5	
CTP/A 2T	005500025	4,400	3"-7-7/8"	3.267	35"	4.921	9.843	4.173	6.102	1.653	3.543	3.937	10.236	8.070	5.471	5.118	0.787	21.8	
CTP/B 2T	005500026	4,400	7-7/8"-11-7/8"	3.267	35"	4.921	9.843	5.365	7.519	1	.653	3.543	3.937	10.236	10.039	7.441	5.118	0.787	22.7
CTP/A 3T	005500027	6,600	3"-7-7/8"	4.37	45"	5.315	10.236	5.039	6.732	1.969	4.331	4.921	12.207	8.661	6.102	5.906	0.866	38.6	
CTP/B 3T	005500028	6,600	7-7/8"-11-7/8"	4.37	45"	5.315	10.236	5.905	8.346	1.969	4.331	4.921	12.207	11.02	8.464	5.906	0.866	43	

CM Series 632 close radius trolley



With revolutionary advances, this shorter, more compact trolley is 50% lighter than competitive trolleys, yet every bit as tough.

- Negotiates radius curves as tight as 7 to 10 inches
- Made of highest quality rolled steel
- Unique double row, ball bearing wheel design for greater wear capacity
- Larger V-bars available for wider flange adjustment
- For low headroom applications
- Bearings pre-packed with lifetime lubricant
- Exclusive Dial-Fit collar quickly adapts trolley to wide range of beams and patented rails
- Dust covers shield and protect bearings
- Trolleys available for larger beams, rails or tracks; contact CM
- Cast iron trolley guards available (except for 3 ton)
- Lifetime warranty
- Made in U.S.A.

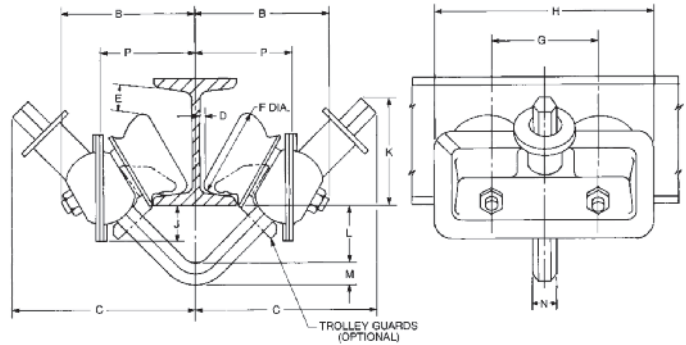

Clearance dimensions (in.)

Dimension	Rated capacity* (tons)			
	1/4 & 1/2	1	1 1/2 & 2	3
Min. radius curve (in.)	7	7	10	10
B	4 1/4	4 3/8	5 5/8	6 3/16
C	5 7/8	6	7 1/2	8 1/16
D	3/16	3/16	3/8	1 1/16
E	1 3/16	1 3/16	2 3/16	4 1/16
F	2 3/4	2 3/4	3 1/2	3 1/2
G	3 3/8	3 3/8	4 1/2	4 1/2
H	7	7	9	9
J	1 1/8	1 1/8	1 1/2	1 5/8
K	3 3/8	3 1/2	4 3/8	4 13/16
L	1 13/16	1 5/8	2	2 5/8
M	1 1/16	7/8	1 1/8	1 1/8
N	7/8	1	1 1/4	1 1/4
P	3	3 1/8	3 7/8	4 15/16

Dimensions given are for minimum S-beam and will vary with larger beams.

*WARNING

Overloading and improper use can result in injury.

To avoid injury:

- Do not exceed working load limit, load rating capacity
- Do not use to lift people or loads over people.
- use only alloy chain for overhead lifting.
- Read and follow all instructions.

Specifications

Rated capacity* (tons)	Product code	Adj. for standard S-beams		Tread diameter (in.)	Net weight (lbs.)	Shipping weight (lbs.)	Minimum radius curve (in.)
		Depth of beam (in.)	Flange width (in.)				
1/4-1/2	3222	4-12	2 5/8-5 1/16	2 3/4	9	10	7
1	3224	4-12	2 5/8-5 1/16	2 3/4	10	12	7
1 1/2-2	3226	6-15	3 3/8-5 5/8	3 1/2	23	25	10
3	3230	8-18	4-6 1/4	3 1/2	29	33	10

All capacities can be supplied for S-beams larger than listed and also for wide flange beams, rails or tracks with approximately equivalent flange widths.

Series 84A plain or geared trolley

Manufactured for heavy duty, industrial grade applications. CM Series 84A trolleys feature fully sealed, precision bearings, heavy duty side frames and fully machined wheel tread for superior performance and **long life — with minimal maintenance.**

- Available in capacities from 1/4 through 25 ton with 30 through 50 ton trolleys available as tandem construction.
- Lifetime lubricated, precision ball bearings on trolleys through 3 ton capacity. Trolleys with capacities 4 tons and greater are equipped with eight sealed, Timken tapered roller bearings and grease fittings.
- Heavy rolled steel side frames extend beyond the wheels to provide these trolleys with superior strength, rigidity and added protection for the trackwheels. Units with capacities from 1/4 through 12 tons employ universal wheel treads for use on flat or tapered beam flanges. Units with capacities from 16 through 25 tons operate on American Standard I-beams with tapered flanges. For patented track, consult factory.
- Trolley wheels are fully machined from alloy cast iron and hardened for high strength and long life.
- Alloy steel axles and equalizer pins are heat treated for maximum strength and wear life.
- Geared versions have fully machined trackwheel gears and incorporate a swinging chain guide which keeps the hand chain aligned and free from jamming.
- Available to fit a broad range of wider flange beams and patented track applications not listed - contact factory.
- Made in the USA
- Spark resistant models available — add suffix “SR”



Specifications

Product code	Rated capacity (tons)	Beam height (in.)	Flange width (in.)	Minimum radius curve (in.)	Approximate net weight		
					Plain	† Geared	
1641-0025	1642-0025	1/4	4 - 12	2.66 - 5.00	20	23	38
1641-0050	1642-0050	1/2	4 - 12	2.66 - 5.00	20	23	38
1641-0100	1642-0100	1	5 - 12	3.00 - 6.00	24	43	62
1641-0150	1642-0150	1 1/2	5 - 12	3.00 - 6.00	24	45	65
1641-0200	1642-0200	2	6 - 18	3.33 - 6.25	30	67	90
1641-0300	1642-0300	3	6 - 18	3.33 - 6.25	30	70	93
1641-0400	1642-0400	4	8 - 24	4.00 - 7.00	36	155	184
1641-0500	1642-0500	5	8 - 24	4.00 - 7.00	36	160	188
1641-0600	1642-0600	6	8 - 24	4.00 - 7.00	36	160	188
1641-0800	1642-0800	8	10 - 24	4.62 - 8.00	60	300	347
1641-1000	1642-1000	10	10 - 24	4.62 - 8.00	60	310	360
1641-1200	1642-1200	12	10 - 24	4.62 - 8.00	60	310	360
1631-1600	1632-1600	16	18 - 24	6.00 - 8.00	96	800	895
1631-2000	1632-2000	20	18 - 24	6.00 - 8.00	96	845	955
1631-2500	1632-2500	25	18 - 24	6.00 - 8.00	120	1045	1200

For wide flange beam adaptation, patented track or for beams larger than standard - contact factory.

† Weight less hand chain. **8 Ft. standard zinc plated hand chain drop on geared trolley.** Specify curve on order.

Series 84A plain or geared trolley-specifications

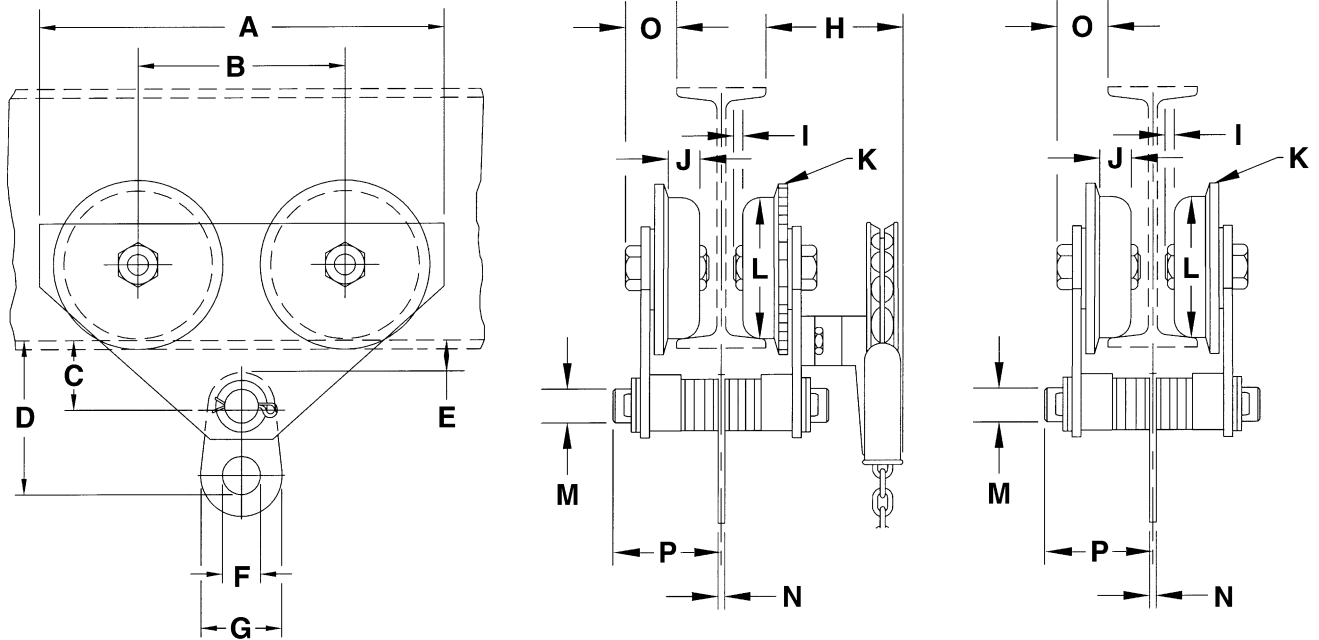

Cap. (tons)	A	B	C	D	E	F	G	H	I	J	K	L	M	N	O	P
1/4	11 1/2	6	1 7/8	4 7/8	7/8	1 3/4	2 3/4	6	—	7/8	4	2 7/8	1	1/4	2	4 1/8
1/2	11 1/2	6	1 7/8	4 7/8	7/8	1 3/4	2 3/4	6	—	7/8	4	2 7/8	1	1/4	2	4 1/8
1	13 1/4	6 3/4	2 1/4	5 3/8	1	1 3/4	3	6 1/8	—	1 1/8	5	3 3/4	1 1/4	1/4	1 3/4	4 3/4
1 1/2	13 1/4	6 3/4	2 1/4	5 3/8	1	2	3 1/4	6 1/8	—	1 1/8	5	3 3/4	1 1/4	3/8	1 3/4	4 3/4
2	15 5/8	7 5/8	2 5/8	6 3/4	1 1/8	2 1/8	3 5/8	6 1/8	—	1 1/8	6	4 1/2	1 1/2	3/8	2 1/8	5 1/4
3	15 5/8	7 5/8	2 5/8	6 7/8	1 1/8	2 1/4	4	6 1/8	—	1 1/8	6	4 1/2	1 1/2	1/2	2 1/8	5 1/4
4	18 3/4	8 1/2	3 1/4	8 3/8	1 1/4	2 3/4	4 3/4	8 1/8	1/8	1 3/8	8	6 3/8	2	5/8	2 5/8	6 1/8
5	18 3/4	8 1/2	3 1/4	8 5/8	1 1/4	3	5 1/2	8 1/8	1/8	1 3/8	8	6 3/8	2	5/8	2 5/8	6 1/8
6	18 3/4	8 1/2	3 1/4	8 5/8	1 1/4	3	5 1/2	8 1/8	1/8	1 3/8	8	6 3/8	2	5/8	2 5/8	6 1/8
8	23 5/8	10 5/8	3 7/8	10 5/8	1 3/8	3 1/2	6 1/2	9	1/8	1 11/16	10	8 1/4	2 1/2	3/4	3 1/4	6 7/8
10	23 5/8	10 5/8	3 7/8	11 1/8	1 3/8	4 1/2	8	9	1/8	1 11/16	10	8 1/4	2 1/2	1	3 1/4	6 7/8
12	23 5/8	10 5/8	3 7/8	11 1/8	1 3/8	4 1/2	8	9	1/8	1 11/16	10	8 1/4	2 1/2	1	3 1/4	6 7/8
16	28 1/4	14	5 7/8	15 1/4	2 1/2	4	9	14 1/2	5/16	2	13 1/2	11 3/4	3 1/4	1 1/2	7	8
20	28 1/4	14	5 7/8	16 5/8	2 1/2	4	10	14 1/2	5/16	2	13 1/2	11 3/4	3 1/4	1 3/4	7	8 1/4
25	28 1/4	14	5 7/8	16 3/4	2 1/8	4	10	14 1/2	5/16	2	13 1/2	11 3/4	3 1/4	1 3/4	7	8 1/4

Notes: All dimensions are in inches.

Wheels with convex treads are standard on all capacities.

20, 25, 30 and 40 ton trolleys can be furnished in tandem construction - Dimensions for 30 through 50 ton units available upon request.

Dimensions shown are for minimum beam size and will vary proportionately for larger beams.

CBT Trolley

Plain or Geared Trolleys – Versatile, Economical, and Reliable

The smooth rolling CM Hoist CBT is the economical choice for most applications. The trolley features steel wrap around side plates, dual tread wheels and lifetime lubricated shielded ball bearings. The CBT Model by CM Hoist is available in plain and geared models.

- **Capacities** - Rated loads from 1/4 to 5 Ton (Metric Rated). In plain and geared models.
- **Economical** - Excellent low cost choice for manual and powered hoists.
- **Rugged** - Designed to provide superior performance and long, efficient service.
- **Low Rolling Effort** - Geared models have standard 6-foot hand chain drop. Other hand chain drops available.
- **Universal Hanging Clevis** - Accepts most hook mounted hoists.
- **Adjustable** - Trolley easily adjusts to fit any beam flange within range of adjustment, up to an 8.7" flange width.
- **Wrap-Around Side Plates** - Lugs provide additional security to increase operator safety and act as bumpers to protect wheels.
- **Dual Tread Wheels** - Will fit either tapered or flat beam flange within range of adjustment. Wheels include permanently lubricated, shielded ball bearings for long life and low maintenance.
- **Lifetime Warranty**

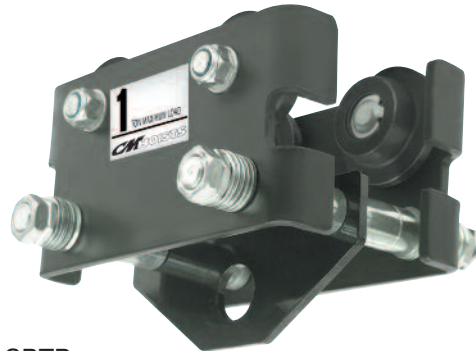

CBTP
(Plain Trolley)
1/4 To 5 Ton



CBTG
(Geared Trolley)
1 To 5 Ton

SPECIFICATIONS - Model CBT

Capacity * (Ton)	Plain Product Code**	Geared Product Code**	Standard Beam Height (In.)	I-Beam Width (In.)	Minimum Radius Curve (In)	Wheel Tread Diameter (In)	Wt. (Lb.)
1/4	CBT(P)-0025		4-24	2.0-8.7	27	2.36	19
1/2	CBT(P)-0050		4-24	2.0-8.7	27	2.36	19
1	CBT(P)-0100	CBT(G)-0100	5-24	2.3-8.7	36	2.36	26
1 1/2	CBT(P)-0150	CBT(G)-0150	6-24	2.3-8.7	45	3.15	46
2	CBT(P)-0200	CBT(G)-0200	6-24	2.3-8.7	45	3.15	46
3	CBT(P)-0300	CBT(G)-0300	8-24	3.0-8.7	55	4.41	86
5	CBT(P)-0500	CBT(G)-0500	10-24	3.5-8.7	70	4.92	130

* Metric Rated

**When ordering specify "P" for plain trolley or "G" for geared trolley

CBT Trolley - Specifications

Dimensional Drawing - 602

Model CBTP/CBTG 1/4-5 Metric Ton

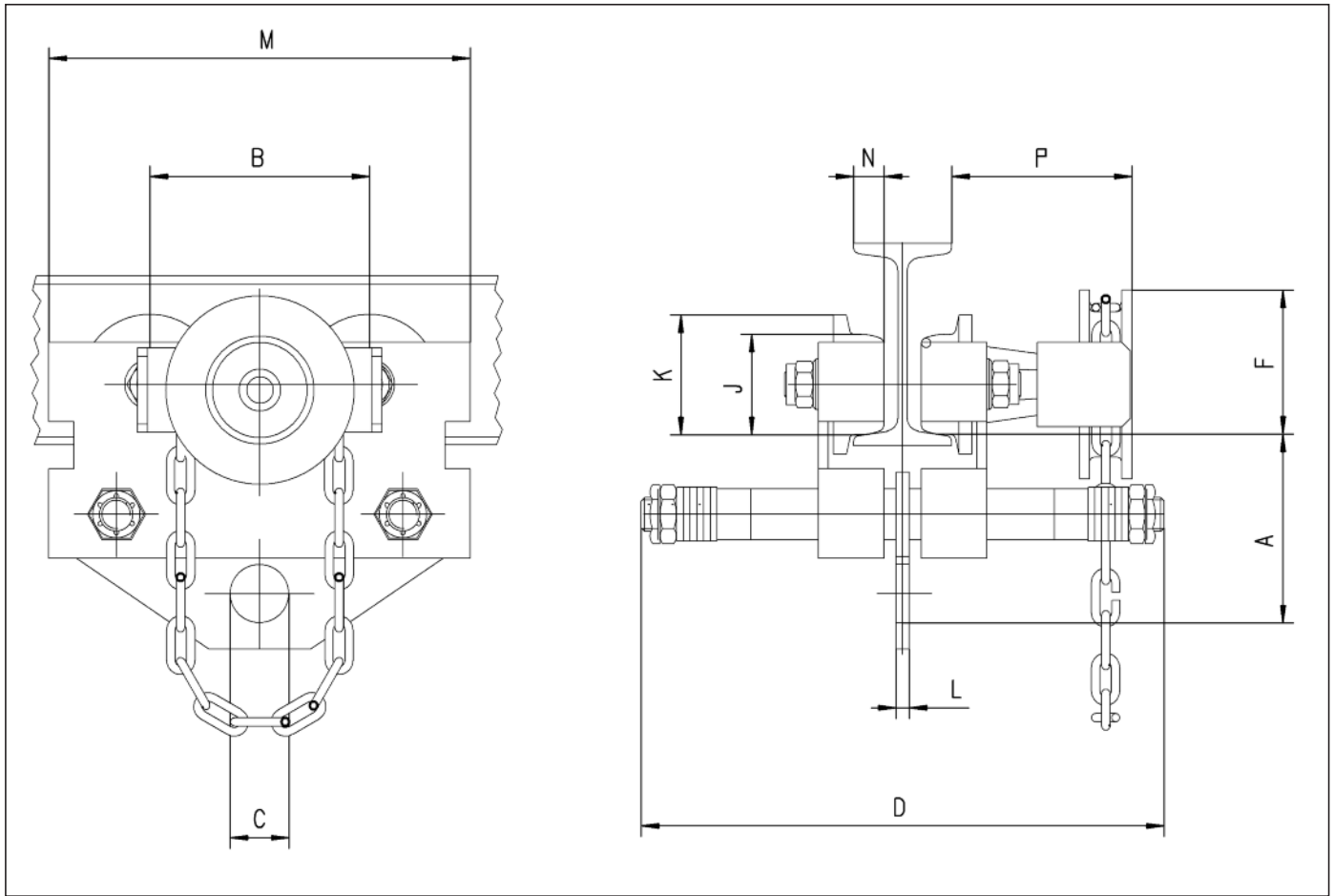

Clearance Dimensions (In.)

Model CBT

Capacity (Ton)	A	B	C	D	CBTG F	J	K	CBTG K	L	M	N	CBTG P
1/4	3.94	3.54	1.18	11.81	-	2.36	2.83	-	.31	7.56	.71	-
1/2	3.94	3.54	1.18	11.81	-	2.36	2.83	-	.31	7.56	.71	-
1	4.33	5.12	1.38	12.20	3.60	2.36	2.83	3.03	.31	9.84	.71	4.33
1 1/2	5.12	5.91	1.89	12.60	3.56	3.15	3.78	3.86	.47	11.81	.79	4.33
2	5.12	5.91	1.89	12.60	3.56	3.15	3.78	3.86	.47	11.81	.79	4.33
3	6.18	7.09	2.36	13.39	4.23	4.41	5.20	5.24	.55	14.57	1.14	4.33
5	7.09	8.23	2.76	13.78	5.89	4.92	5.63	5.87	.79	17.32	1.26	4.33

CM Series 633 wide range trolley

Simple, rugged, built for trouble-free service and ease of operation across a wide range of beam applications. Series 633 features:

- Rugged steel side plates formed to include bumpers and trolley guards
- Frames connected by steel equalizer pin, secured by two nuts on each side
- Universal tread flanged trackwheels equipped with shielded ball bearings
- Easy rolling on American standard shapes, wide flange shapes or patented rail
- Hardened wheels and axles for added strength and durability
- Spacer washers can be shifted inside or outside for easy adjustment to wide range of beams
- To be used with hook suspended hoist
- Suspension plate for easy attachment is standard
- Bearings pre-packed with lifetime lubricant
- One-year warranty
- Imported
- Metric Rated

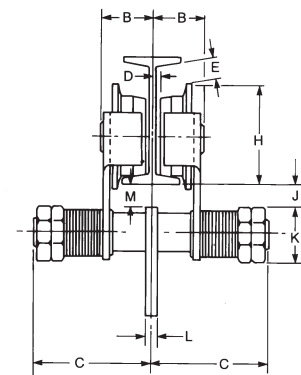
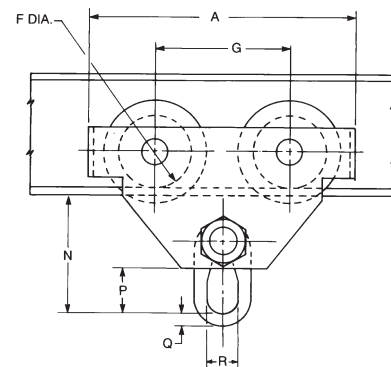

Clearance dimensions (in.)

Dimension	Rated capacity* (tons)				
	1/2	1	2	3	5
Min. radius curve (in.)	35	35	59	71	94
A	8 1/2	10 13/16	12 7/32	14 13/16	18 1/8
B**	2 5/32	2 13/32	2 11/16	3 1/16	3 21/32
C	5 1/16	6 9/16	6 25/32	7 13/32	8
D**	1/16	7/16	13/32	1/2	9/16
E**	-1/4	11/32	25/32	17/16	23/16
F	2 9/32	3 15/32	3 15/16	5 1/8	6 1/8
G	4	4 7/8	5 1/2	6 9/16	7 7/8
H**	3	4 11/32	4 29/32	6 1/8	7 9/32
J**	1 1/32	1 1/32	25/32	13/16	2 1/8
K	1 3/4	2 3/32	2 1/2	3 13/32	3 13/32
L	1/2	1/2	5/8	5/8	13/16
M**	15/16	31/32	5/16	15/16	17/16
N**	4 3/32	5 1/16	5 13/16	7 7/16	9 15/16
P	1 7/32	1 3/4	2 5/32	2 9/16	3 23/32
Q	1 9/32	1 9/32	1 3/16	1 3/8	1 25/32
R	3 1/32	1 5/32	1 5/8	1 31/32	2 9/16

**Dimensions given are for minimum S-beam and will vary with larger beams.

Specifications

Rated capacity* (tons)	Product code	Adj. for standard S-beams			Net weight (lbs.)	Shipping weight (lbs.)
		Depth of beam (in.)	Flange width (in.)	Tread diameter (in.)		
1/2	3302	3-15	2 1/2-5 5/8	2 9/32	15	17
1	3304	5-24	3-8	3 15/32	34	36
2	3306	6-24	3 5/8-8	3 15/16	50	53
3	3307	8-24	4-8	5 1/8	95	100
5	3309	10-24	4 5/8-8	6 1/8	172	175

RailStar motor driven trolley



- Fits wide range of beam sizes for maximum versatility
- Universal use with any hook suspended single speed hoists that are equipped with reversing contactor
- Steel spur gearing for optimum strength and smooth operation
- Durable hardened cast iron trackwheels that operate on standard S-beams or flat flanged beams
- Lifetime lubricated double row ball bearings for high efficiency, low maintenance
- Cast iron control enclosure
- Four-button control station included for operating single speed hoist. Drop proportioned to 20' lift
- Steel plate side frames
- 115 volt control circuit on 1 phase units
48 volt control circuit on 3 phase units
- Trolley guards standard
- One-year warranty
- Metric rated
- Imported

Clearance dimensions (in.)

Dimension	Rated capacity* (tons)	
	1/8 - 2	3
A	12 ³ / ₄	14 ¹ / ₈
B	6 ³ / ₈	6 ³ / ₄
C**	4 ¹³ / ₁₆	5 ¹ / ₄
D	3 ⁹ / ₁₆	3 ¹⁵ / ₁₆
E	2 ⁹ / ₁₆	2 ¹⁵ / ₁₆
F**	4 ³ / ₄	5 ³ / ₁₆
G**	6	6 ⁵ / ₁₆
H**	17 ft.	17 ft.
J	7 ¹ / ₂	9 ¹⁵ / ₁₆
K	4 ¹ / ₈	4 ¹¹ / ₁₆
SINGLE PHASE L	12 ³ / ₄	15 ³ / ₁₆
THREE PHASE L	11 ⁷ / ₁₆	13 ⁷ / ₈
M**	1 ¹ / ₂	2 ¹⁵ / ₁₆
N**	3/8	3/4
P**	1 ⁷ / ₁₆	1 ⁹ / ₁₆
Q**	5 ¹ / ₈	5 ⁷ / ₈
R	1/2	3/4
S	1 ¹ / ₁₆	1 ¹ / ₁₆
T**	8 ⁷ / ₈	9 ⁹ / ₁₆

**Dimensions given are for minimum S-beam and will vary with larger beams.

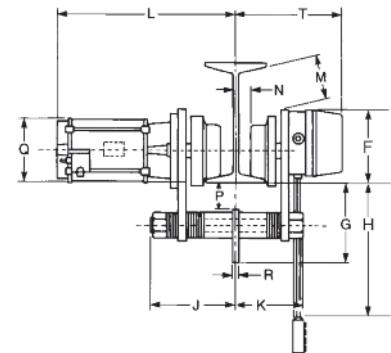
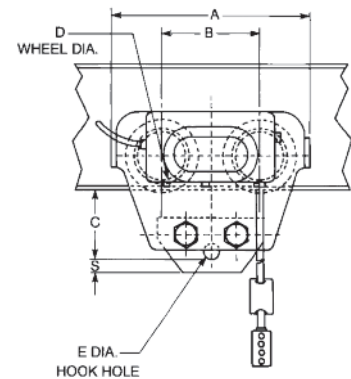

Specifications

Rated capacity (tons)	Product Code	Operating Voltage		Phase	Travel Speed		Motor H.P.	Min. beam size	Max. beam size	Shipping weight (lbs)
		50 hertz	60 hertz		50 hertz (F.P.M.)	60 hertz (F.P.M.)				
1/8-2	0300	220/380-415	220-240/440-480	3	65	78	1/3	S6x12.5	S18x54.7	108
1/8-2	0301	n/a	110-120	1	n/a	78	1/3	S6x12.5	S18x54.7	113
3	0302	220/380-415	220-240/440-480	3	65	78	3/4	S8x18.4	S24x79.9	185
3	0303	n/a	110-120	1	n/a	78	3/4	S8x18.4	S24x79.9	190

Note: Three phase units are reconnectable for high and low range voltage

*WARNING

Overloading and improper use can result in injury.

To avoid injury:

- Do not exceed working load limit, load rating capacity
- Do not use to lift people or loads over people.
- use only alloy chain for overhead lifting.
- Read and follow all instructions.

Tractor drive

Power tractor drives push-type hoists, trolleys and underhung cranes. Easy installation without removing or modifying existing equipment. This drive also features:

- Compact design
- Capacities up to 5 tons available in 230/460-3-60 operation
- Monorail trolley track or twin unit synchronized drives available
- Direct drive with right angle worm gear reducer
- Enclosed aluminum housing for lubrication of gears and bearings
- Steel plate construction with tie-rods for easy adjustment
- Squirrel cage motor with permanently lubricated bearings
- Fully machined trolley wheels with universal tread operate on tapered or flat flange beams
- Adjusts to standard I-beams or flat flange beams up to 8 inches wide
- Standard magnetic reversing contactor with mechanical interlock inside NEMA 1 enclosure
- One-year warranty
- Made in U.S.A.

Options

- 575 volt 3 phase 60 hertz operation
- 2, 4, 6 & 8 button push-button station
- Additional push-button cable length (10' standard)
- NEMA 12, 4 or 4X control enclosures
- Motor brake
- Soft start (recommended for speeds above 70 F.P.M.)
- Two speed or variable controls
- Transformer for 115 volt control power
- Tow bar
- For other beams, options or custom designs, consult factory

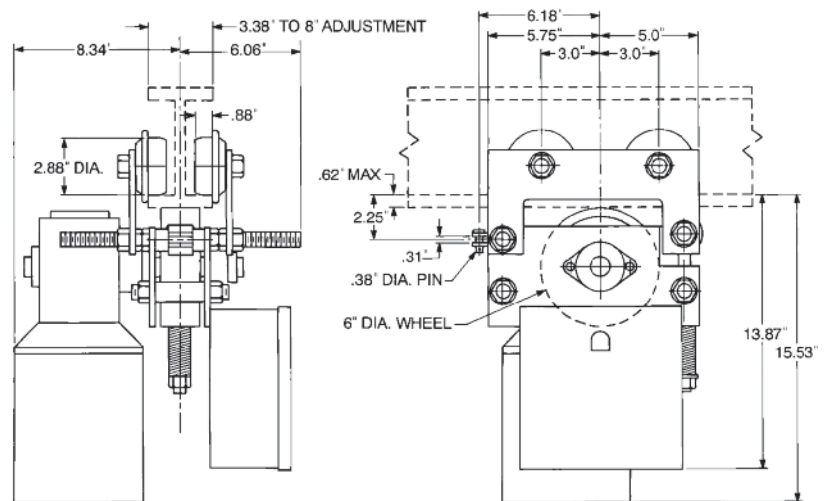

Rated capacity* (tons)	Product code	Speed (F.P.M.)	Motor H.P.	Motor RPM	Std. beam size (in.)	Min. radius curve (in.)	Approx. Max. flange thickness (in.)	shipping wt. (lbs.)
1	TD 235	35	1/4	900	3.38-8	36	.62	110
1	TD 255	55	1/4	900	3.38-8	36	.62	110
1	TD 270	70	1/4	900	3.38-8	36	.62	110
1	TD 2105	105	1/4	900	3.38-8	36	.62	110
1½	TD 335	35	1/4	900	3.38-8	36	.62	110
1½	TD 355	55	1/4	900	3.38-8	36	.62	110
1½	TD 370	70	1/4	900	3.38-8	36	.62	110
1½	TD 3105	105	1/4	900	3.38-8	36	.62	110
2½	TD 535	35	1/4	900	3.38-8	36	.62	110
2½	TD 555	55	1/4	900	3.38-8	36	.62	110
2½	TD 570	70	1/4	900	3.38-8	36	.62	110
3	TD 635	35	1/4	900	3.38-8	36	.62	110
3	TD 655	55	1/4	900	3.38-8	36	.62	110
5	TD 1035	35	1/4	900	3.38-8	36	.62	110

Hoist Test Stand - 12 Ton Capacity

The Value - Priced, Hydraulic Hand Operated Test Stand — Tests Hoist Capacity to 12 Tons

The Value-Priced CM Test Stand is specially designed for the testing of hoisting equipment as required by the applicable sections of ASME Code B30.16. Unlike other test stands on the market that weigh thousands of pounds, the CM Value-Priced Test Stand weighs only 496 pounds. Portability for on-site testing becomes more practical. Fewer wearing parts provide superior performance.

- Hand operated hydraulic pump eliminates the need for electrical power.
- Capable of applying test loads up to 12 tons.
- Compact, self-contained design for portability and on-site testing.
- Eliminates the need for cumbersome test weights.
- Capable of both static and dynamic testing.
- Tests the function of overload devices.
- Rugged steel frame construction for strength and durability.
- High quality, high strength, hydraulic cylinder made from chromium-molybdenum steel, heat treated for long life and chrome plated for added protection.
- Two-stage, quick action hand pump for ease of operation.
- Fine adjustment pressure valve for accurate load testing.
- Large pressure gauge for easy reading.
- Made in USA

Technical data

Hydraulic Cylinder (hollow)

- | | |
|-----------------------|--------------------------------|
| Type | • Single acting, spring return |
| Maximum pulling force | • 12 tons @ 5800 p.s.i. |
| Stroke | • 6 in. |
| System pressure | • 0 - 5800 p.s.i. |
| Center hole diameter | • .87 in. |

Hydraulic Hand Pump

- | | |
|-----------------|--|
| System pressure | • 0 - 6090 p.s.i. |
| Reservoir | • 1.47 pints |
| Valve | • Two-stage, fine adjustment pressure preset |
| Gauge | • Glycerin filled - 3.94 in. dia. |

Frame

- Mounting holes in base for permanent mount

Total Weight

- 496 lbs.

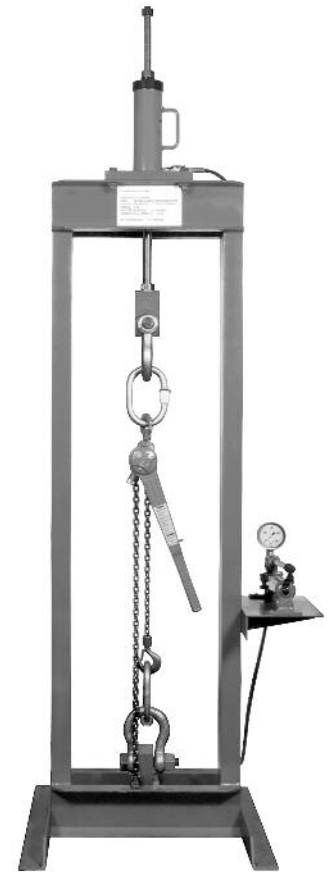

12 Ton Test Stand
Product Code 1200

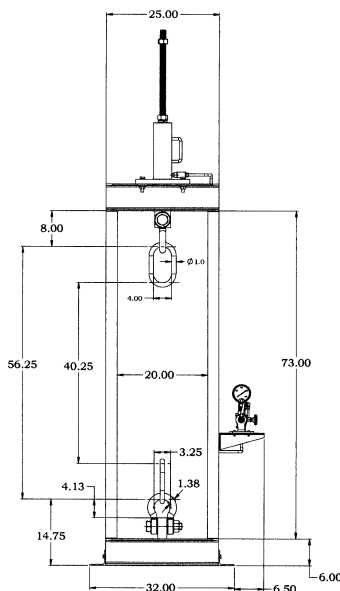

Front View

All Dimensions In Inches

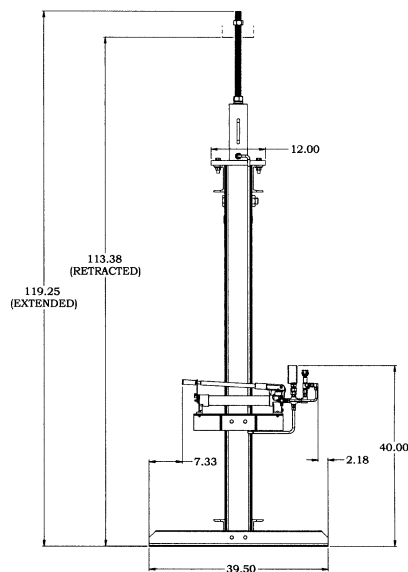

Side View

All Dimensions In Inches

*WARNING

Overloading and improper use can result in injury.

To avoid injury:

- Do not exceed maximum pulling force of 12 tons
- Read and follow all instructions.

Rocket Universal Pendant Control

The CM® Rocket™ universal pendant control is engineered for maximum operator comfort, while delivering the precision control your application demands.

At the heart of the CM Rocket is a unique rocker switch that is ergonomically designed to reduce thumb strain and fatigue. The rocker switch gives the operator ultimate load control for micro-positioning applications, as well as increased safety and efficiency for hoist and machine operators. Its curved, well-balanced shape and ribbed grip help ensure the operator maintains a secure and comfortable hold.

The patented CM Rocket can be used for momentary operation of numerous types of industrial equipment, including hoists, conveyors, lift elevators and lift gates, mill drives, actuators and winches. This versatile pendant control is available in 4 configurations:

- Single-speed pendant
- Single-speed pendant with emergency stop
- 2-speed pendant
- 2-speed pendant with emergency stop

Experience the CM Advantage. Compared to the competitors' traditional straight grip and push-button configurations, the CM Rocket's comfort-fit design and responsive rocker switch give operators maximum control with minimal effort.



Specifications:

FITS YOUR HOIST & INDUSTRIAL EQUIPMENT

The adjustable rubber grommet easily accepts multiple power cable sizes from .33" to .64" diameter.

DUAL STRAIN RELIEF

The CM Rocket can be connected with internal or external strain relief.

CURVED, COMFORT-FIT DESIGN

Well-balanced design fits comfortably in the palm of your hand, requiring minimal wrist flexion for operation to reduce operator fatigue and hand strain.

RIBBED GRIP

Unlike the competitors' smooth grip, the ribbed construction of the CM Rocket's grip provides a secure hold in all environments.

DURABLE CASING

Pendant is made of durable ABS plastic that is shock, corrosion and moisture resistant.

MEETS HIGH PERFORMANCE STANDARDS

The CM Rocket pendant is NEMA 4/4X (IP65) approved for indoor industrial service only and temperature rated for indoor use at -0°C (32° F).

READY TO INSTALL

The Rocket pendant is easy to install and comes with everything you need to be up and running in minutes, including fasteners, labels, a cord warning tag and installation instructions.

OPTIONAL EMERGENCY STOP

Large emergency stop button is easy to operate with simple push-down, twist-to-release operation for compliance with OSHA-required safeguarding measures. Emergency stop is optional and available on single-speed and 2-speed pendants.

ROCKER SWITCH

Rocker switch requires minimal thumb movement and push force, reducing strain on thumb and hand. It allows the operator to control hoists and other industrial equipment with precision control and accuracy. The wide shape of rocker switch ensures easy operation with or without gloves.

PROTECTIVE GASKET

A rubber gasket seated under the rocker switch prevents environmental contaminants from entering the pendant.

RUGGED DIRECTIONAL INDICATORS

Directional indicators feature raised, non-slip ridges for ease of use and secure thumb placement. Ridges will not wear quickly, like the competitors' stickers or printed indicators.

UNIVERSAL DESIGN FITS YOUR HOIST

The CM Rocket pendant control was engineered to be used with virtually every electric chain hoist from Columbus McKinnon – simplifying the ordering process and making your inventory management easier.

The CM Rocket is available as an option on all of the hoists listed in the chart below.* And, for easy ordering, we've made it a standard option on one of our newest hoists, the CM ShopStar VS**.

All Rocket pendant controls come with a complement of adhesive decals that allow users to brand the pendant to match their Budget, CM, Coffing or Yale hoist.

AFTER-MARKET AVAILABILITY

The CM Rocket is also available as an after-market product for use on CMCO and competitor hoists as well as conveyors, lift gates and other industrial equipment.

BRAND	MODEL	PENDANT AVAILABLE ON		ORDER PENDANT AS	
		SINGLE-SPEED MODEL	2-SPEED MODEL	ENGINEERED SPECIAL	STANDARD OPTION
BUDGIT[®] Hoists	MANGUARD	✓	✓	✓	
	SHOPHOIST	✓	not available	✓	
CM	LODESTAR CLASSIC	✓	✓	✓	
	LODESTAR	✓	✓	✓	
	LODESTAR XL	✓	✓	✓	
	MAN GUARD	✓	✓	✓	
	POWERSTAR	✓	✓	✓	
	SHOPSTAR	✓	not available	✓	
	SHOPSTAR VS**	✓	✓		✓
	VALUSTAR	✓	not available	✓	
COFFING[®] HOISTS	EC	✓	✓	✓	
	EMW	✓	✓	✓	
	JLC	✓	✓	✓	
	SLC	✓	not available	✓	
	WR	✓	✓	✓	
Yale[®] HOISTS	KELC	✓	✓	✓	
	XL	✓	✓	✓	
	YJL	✓	✓	✓	

* Not available for 3-step infinitely variable hoist models.

** Pendants with emergency stop not available on CM ShopStar VS.

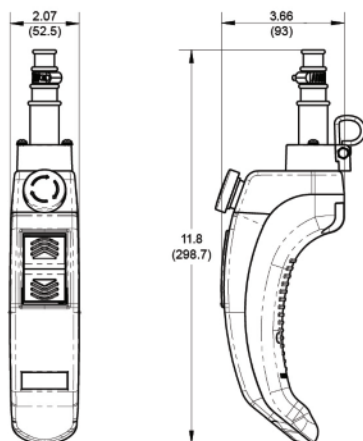

SPECIFICATIONS

Product Code	Description	Length in. (cm)	Width in. (cm)	Height in. (cm)	Weight oz. (kg)
ECUR-1S	Single-Speed, No E-Stop	3.66 (93)	2.07 (52.5)	11.8 (298.7)	10.5 (297)
ECUR-1SE	Single-Speed with E-Stop	3.66 (93)	2.07 (52.5)	11.8 (298.7)	10.5 (297)
ECUR-2S	2-Speed, No E-Stop	3.66 (93)	2.07 (52.5)	11.8 (298.7)	10.5 (297)
ECUR-2SE	2-Speed with E-Stop	3.66 (93)	2.07 (52.5)	11.8 (298.7)	10.5 (297)

ACCESSORIES

ECUR-0010	Switch Repair Kit, 2-Speed, 4 Switch	ECUR-0001	Strain Relief Kit
ECUR-0011	Switch Repair Kit, Single-Speed, 2 Switch	ECUR-0030	Label Kit
ECUR-0020	Enclosure Repair Kit, No E-Stop	23608124	Emergency Stop Push Button
ECUR-0021	Enclosure Repair Kit, With E-Stop	23608110	Cable Bushing

THE POWER OF INTELLIGENT LIFTING

Columbus McKinnon is one of the most respected and well-known names in the material handling industry. We combine two different yet complimentary areas of expertise – rigging products and hoists – to develop complete floor-to-ceiling lifting systems for even the most unique material handling applications.

Columbus McKinnon designs and manufactures a large portfolio of durable and reliable products for a variety of industries. Our portfolio includes powered and manual hoists, rigging products, below-the-hook attachments, cranes, enclosed track systems and specially engineered products.



KNOW HOW. KNOW WHY. BE SAFE. GET TRAINED.



Not only is Columbus McKinnon a leader in material handling products, we are also a global leader in providing expertise and training on the proper use and inspection of rigging and overhead lifting equipment. With a range of comprehensive programs and seminars conducted at venues throughout North America, including our hands-on training centers and private companies, our courses include:

- Hoist Maintenance
- Crane & Hoist Inspection
- Crane Operator Training
- Safe Hoisting
- Load Securement
- Rigging
- Rigging Gear Inspection

One of our newest programs, **CMCO University™**, is a three-day course designed to give attendees an intimate knowledge of our products, the information they'll need to select the right product for the application, and the tools to win in the marketplace.

Classes are available at our state-of-the-art, hands-on training centers, including the **Niagara Training Center** and the **Hoist & Rigging Training Center of Excellence in the Center for Occupational Health and Automobile Manufacturing (COHAM) lab at The Ohio State University**.

Rely on Columbus McKinnon for the products and expertise you need to keep your workforce productive and safe.



USA: Ph: (800) 888.0985 • (716) 689.5400 • Fax: (716) 689.5644
CANADA: Ph: (877) 264.6478 • Fax: (877) 264.6477

