

ETA-4 TELESCOPING UNITS

RATED LOAD: BASED UPON STATIC LOAD TESTING AND CARRYING CAPACITY OF HIGH IMPACT WHEELS.
 TEST LOAD: SHALL NOT BE MORE THAN 125% OF THE RATED LOAD UNLESS RECOMMENDED BY THE MANUFACTURER.
 CRANE SHALL NOT BE LOADED BEYOND IT'S RATED LOAD CAPACITY EXCEPT FOR TEST PURPOSES.

NOTE:
 FOR CONFIGURATIONS AND LOADS NOT SHOWN CONSULT FACTORY.

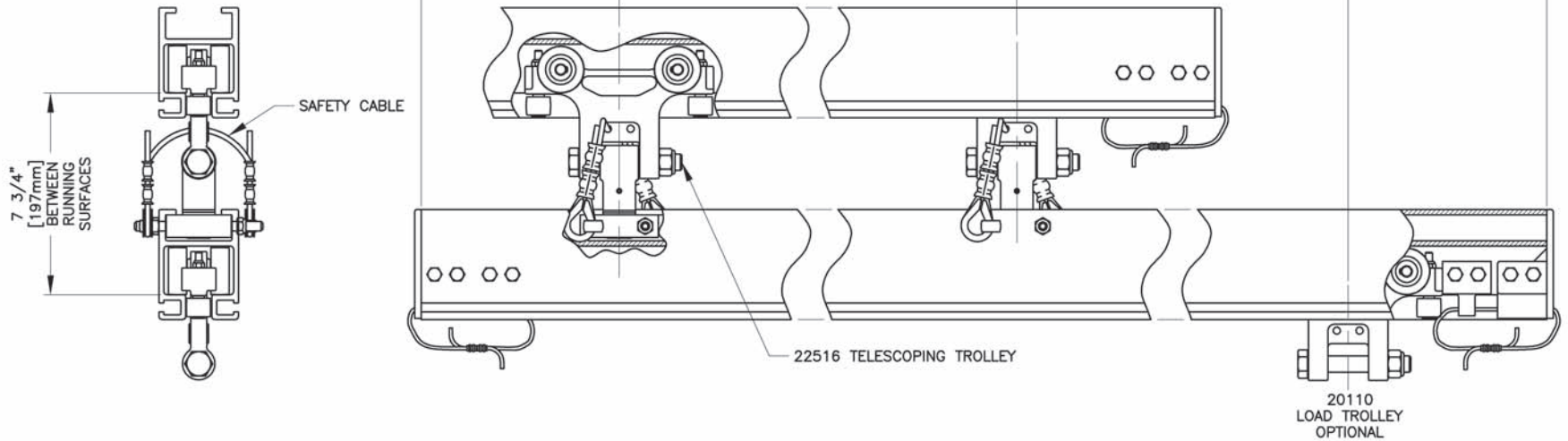

ETA-4 TELESCOPE UNIT															
"A"	"B"	RATED LOAD		"A"	"B"	RATED LOAD		"A"	"B"	RATED LOAD		"A"	"B"	RATED LOAD	
		L/250	L/450			L/250	L/450			L/250	L/450			L/250	L/450
18 INCH	24 in.	200 lbs.	200 lbs.	24 INCH	24 in.	235 lbs.	235 lbs.	30 INCH	24 in.	265 lbs.	265 lbs.	36 INCH	24 in.	285 lbs.	250 lbs.
	36 in.	150 lbs.	150 lbs.		36 in.	185 lbs.	165 lbs.		36 in.	210 lbs.	150 lbs.		36 in.	230 lbs.	135 lbs.
	48 in.	120 lbs.	105 lbs.		48 in.	150 lbs.	95 lbs.		48 in.	170 lbs.	90 lbs.		48 in.	155 lbs.	85 lbs.
48 INCH	24 in.	315 lbs.	215 lbs.	48 INCH	24 in.	315 lbs.	215 lbs.	48 INCH	24 in.	285 lbs.	250 lbs.	48 INCH	24 in.	315 lbs.	215 lbs.
	36 in.	215 lbs.	115 lbs.		36 in.	215 lbs.	115 lbs.		36 in.	230 lbs.	135 lbs.		36 in.	215 lbs.	115 lbs.
	48 in.	135 lbs.	70 lbs.		48 in.	135 lbs.	70 lbs.		48 in.	155 lbs.	85 lbs.		48 in.	135 lbs.	70 lbs.

ETA-4 TELESCOPE UNIT															
"A"	"B"	RATED LOAD		"A"	"B"	RATED LOAD		"A"	"B"	RATED LOAD		"A"	"B"	RATED LOAD	
		L/250	L/450			L/250	L/450			L/250	L/450			L/250	L/450
457 mm	610mm	91 Kg.	91 Kg.	610 mm	610mm	107 Kg.	107 Kg.	762 mm	610mm	120 Kg.	120 Kg.	914 mm	610mm	129 Kg.	113 Kg.
	914mm	68 Kg.	68 Kg.		914mm	84 Kg.	75 Kg.		914mm	95 Kg.	68 Kg.		914mm	104 Kg.	61 Kg.
	1219mm	54 Kg.	48 Kg.		1219mm	68 Kg.	43 Kg.		1219mm	77 Kg.	41 Kg.		1219mm	70 Kg.	39 Kg.
1219 mm	610mm	143 Kg.	98 Kg.	1219 mm	610mm	143 Kg.	98 Kg.	1219 mm	610mm	129 Kg.	113 Kg.	1219 mm	610mm	143 Kg.	98 Kg.
	914mm	98 Kg.	52 Kg.		914mm	98 Kg.	52 Kg.		914mm	104 Kg.	61 Kg.		914mm	104 Kg.	61 Kg.
	1219mm	61 Kg.	32 Kg.		1219mm	61 Kg.	32 Kg.		1219mm	70 Kg.	39 Kg.		1219mm	70 Kg.	39 Kg.